

SAMSUNG

Climate Solutions



Product Catalogue

**Residential &
Light Commercial**

2020

Highlights for 2020

Wind-Free™

Samsung introduced the market's first air conditioner with Wind-Free™ technology in 2017. Wind-Free™ Cooling disperses fresh air gently and evenly through thousands of micro-holes, creating "Still Air" conditions¹. It allows people to live, work and relax comfortably without experiencing unpleasant cold drafts. For 2020, Samsung is introducing a completely new Wind-Free™ range in a modernised design, featuring new intelligent technologies for enhanced indoor comfort and improved energy efficiency.

With the announcement of the new Wind-Free™ range, Samsung simultaneously renews its offer of other wall-mounted air conditioners for 2020. Superseding the New Triangle and Boracay models, the new Samsung Cebu and Luzon models benefit from similar technological improvements and feature the same newly designed platform with a rectangular and clean silhouette, that fits harmoniously into any space.



Wind-Free™ Elite



Wind-Free™ Cooling



Wi-Fi Control



AI Auto Comfort



Tri-Care Filter



Motion Detect Sensor



R32 Refrigerant

- New compressor with Digital Inverter Boost technology for improved energy efficiency.
- Equipped with NASA communication protocol.
- Available for Residential (RAC) in capacity range 2.5–3.5 kW.
- Available for Multi Split (FJM) in capacity range 2.0–6.8 kW.

A+++ | A+++



Wind-Free™ Avant



Wind-Free™ Cooling



Wi-Fi Control



AI Auto Comfort



Tri-Care Filter



R32 Refrigerant

- New compressor with Digital Inverter Boost technology for improved energy efficiency.
- Equipped with NASA communication protocol.
- Available for Residential (RAC) in capacity range 2.5–6.8 kW.
- Available for Multi Split (FJM) in capacity range 2.0–6.8 kW.
- Available from mid-2020 for Commercial (CAC) in capacity range 2.6–7.1 kW.

A++ | A++



Wind-Free™ Comfort



Wind-Free™ Cooling



Wi-Fi Control



AI Auto Comfort



R32 Refrigerant

- New compressor with Digital Inverter Boost technology for improved energy efficiency.
- Equipped with NASA communication protocol.
- Available for Residential (RAC) in capacity range 2.5–6.8 kW.
- Available for Multi Split (FJM) in capacity range 2.0–6.8 kW.

A++ | A+

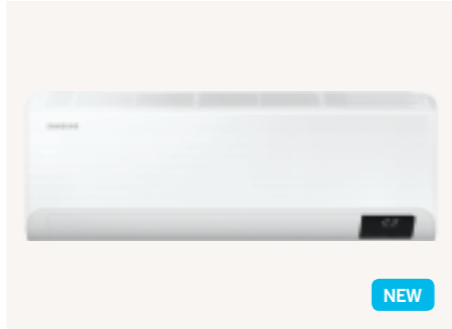

Cebu



Wi-Fi Control



AI Auto Comfort



R32 Refrigerant

- New compressor with Digital Inverter Boost technology for improved energy efficiency.
- Equipped with NASA communication protocol.
- Available for Residential (RAC) in capacity range 2.5–6.8 kW.
- Available for Multi Split (FJM) in capacity range 2.0–6.8 kW.

A++ | A+

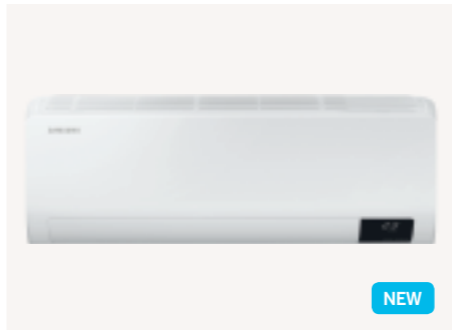

Luzon



R32 Refrigerant

- New compressor with Digital Inverter Boost technology for improved energy efficiency.
- Equipped with NASA communication protocol.
- Available for Residential (RAC) in capacity range 2.5–6.8 kW.
- Available for Multi Split (FJM) in capacity range 2.0–6.8 kW.

A++ | A+



AR35 and AR30



R32 Refrigerant

- AR35 available for Residential (RAC) in capacity range 2.5–6.8 kW.
- AR30 available for Residential (RAC) in capacity range 2.5–3.5 kW.

A++ | A+

¹ASHRAE (the American Society of Heating, Refrigeration, and Air-Conditioning Engineers) defines "Still Air" as air currents moving at speeds below 0.15 m/s, with no cold drafts.

Energy labels as shown are based on 9k Btu versions and are according to EU No 626/2011 (LOT10) label classification 2019, on a scale from D to A+++.
For more detailed product information and technical specifications, please consult the respective product pages of this Product Catalogue.

Product overview

Residential (RAC)

A Samsung Residential single split air conditioner is relatively easy to install and connects an outdoor unit to one single wall-mounted indoor unit. It is an ideal climate solution for the targeted cooling or heating of single rooms, ranging from living rooms to bedrooms.

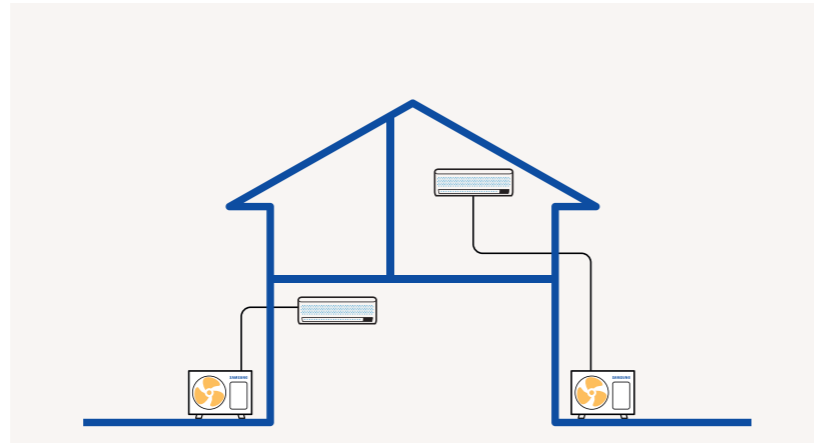

Multi Split (FJM)

The versatility of a Samsung Multi Split air conditioner allows the option of connecting an outdoor unit to up to five indoor units. This is the recommended option when the indoor climate of multiple rooms has to be individually managed, such as in houses or small business premises.

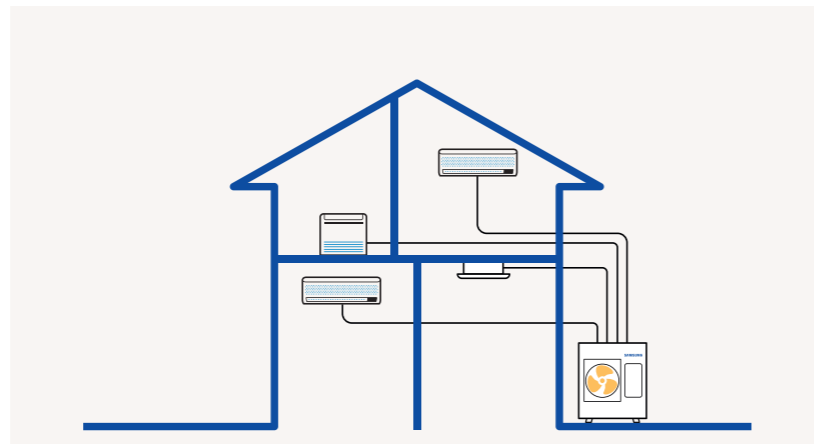

Commercial (CAC)

A Samsung Commercial air conditioning system is designed for cooling or heating larger areas, requiring larger capacities and multiple indoor units to function in unison. This is the optimal climate solution for light commercial applications, such as medium-sized retail spaces or offices.

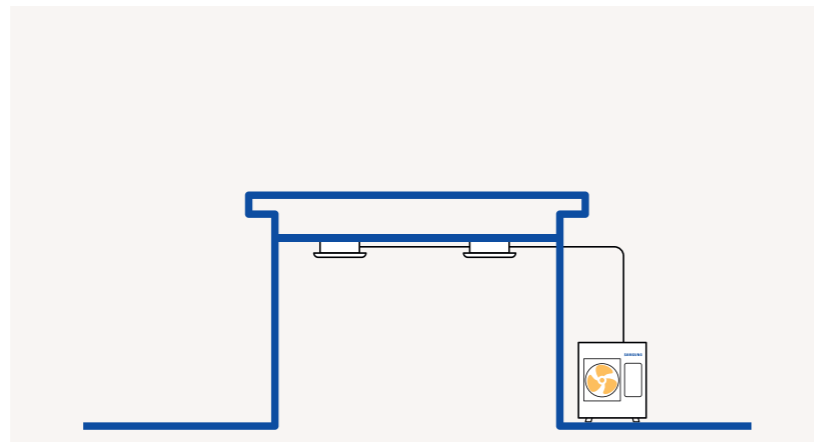

Available Samsung product range				Outdoor units	Controls	
Indoor units						
Wall-Mounted	360 Cassette	4-Way Cassette	1-Way Cassette	R32	Wireless	Wired
Duct	Floor	Ceiling	Console	R410A	Centralised	

Available Samsung product range				Outdoor units	Controls	
Indoor units						
Wall-Mounted	360 Cassette	4-Way Cassette	1-Way Cassette	R32	Wireless	Wired
Duct	Floor	Ceiling	Console	R410A	Centralised	

Available Samsung product range				Outdoor units	Controls	
Indoor units						
Wall-Mounted	360 Cassette	4-Way Cassette	1-Way Cassette	R32	Wireless	Wired
Duct	Floor	Ceiling	Console	R410A	Centralised	

Schematic drawings are for illustrative purposes only. For accurate installation information please consult the technical data book. The selection of the exact product is subject to specific application conditions. For more detailed product information and technical specifications, please consult the respective product pages of this Product Catalogue.

= available as Wind-Free™. Wind-Free™ version of Wall-Mounted for Commercial (CAC) will be available from mid-2020.



Table of contents

Introduction

Samsung Climate Solutions at a glance
 Reference projects in the spotlight
 Regulations and standards

Innovations in detail

Wall-Mounted **NEW**
 360 Cassette **MARKET FIRST**
 Wind-Free™ 4-Way Cassette **MARKET FIRST**
 Wind-Free™ 1-Way Cassette **MARKET FIRST**
 Duct S
 Slim Duct S

Residential (RAC)

Line-up
 Selection guide
 Nomenclature
 Wind-Free™ Elite **NEW**
 Wind-Free™ Avant **NEW**
 Wind-Free™ Comfort **NEW**
 Cebu **NEW**
 Luzon **NEW**
 AR35 and AR30 **NEW**
 Nordic Smart
 Nordic Comfort

Multi Split (FJM)

Line-up
 Selection guide
 Nomenclature
 Compatibility guide
 Outdoor units **NEW**
 Wind-Free™ Elite **NEW**
 Wind-Free™ Avant **NEW**
 Wind-Free™ Comfort **NEW**
 Cebu **NEW**
 Luzon **NEW**
 Wind-Free™ Mini 4-Way Cassette **MARKET FIRST**
 Wind-Free™ 1-Way Cassette **MARKET FIRST**
 MSP Duct
 LSP Slim Duct
 Console

Commercial (CAC)

Line-up
 Selection guide
 Nomenclature
 Twin/triple/quad combinations
 360 Cassette **MARKET FIRST**
 Wind-Free™ Mini 4-Way Cassette **MARKET FIRST**
 Wind-Free™ 4-Way Cassette **MARKET FIRST**
 Wind-Free™ 1-Way Cassette **MARKET FIRST**
 LSP Duct
 MSP Duct
 HSP Duct
 Triangle Wall-Mounted
 Max Wall-Mounted
 Console
 Ceiling
 Big Ceiling
 Floor-Standing
 4-Way Cassette High Efficiency
 Mini 4-Way Cassette High Efficiency
 MSP Duct High Efficiency
 Max Wall-Mounted High Efficiency

Controls

Line-up
 Features and dimensional drawings

Accessories

Line-up

Design and support

Samsung Climate Solutions Partner Portal
 Samsung specialist design support
 Samsung Climate Solutions Academy

This document may either contain preliminary values or may lack some values that were not yet available at the time of creation. To obtain the latest information, please consult the Samsung Climate Solutions Partner Portal at partnerhub.samsung.com/climate or contact your direct Samsung representative.

Samsung Climate Solutions at a glance

Climate solutions that we offer

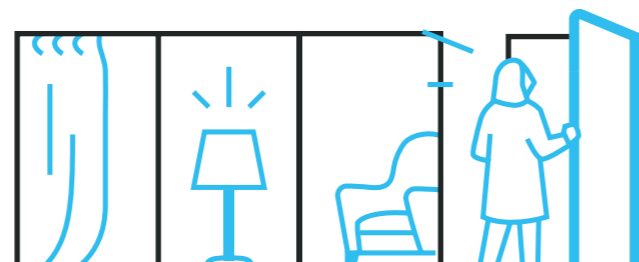

At Samsung, we focus on providing cutting-edge innovations in indoor climate comfort and being a leader in intelligent digital connectivity solutions.

Our market-centric product ranges

	Home	Hotel	Retail	Office	Restaurant	Education
Residential	RAC FJM					
Light Commercial	CAC FJM			CAC		
Commercial		DVM HVM ERV				
Heating	EHS					
Controls	CONTROLS					



Services we provide to empower our partners

Milestone highlights that make us proud

1974

Samsung introduces its first air conditioner.

2005

Samsung Electronics enters the European market for commercial air conditioning.

2017

Samsung Electronics opens Samsung Electronics Air Conditioner Europe B.V. (SEACE) in Amsterdam.

2014



Arrival of the Samsung TDM concept, an all-in-one heat pump solution for heating, cooling and domestic hot water supply.

2015



Introduction of the Samsung 360 Cassette, the world's first circular air conditioner that fits seamlessly into the design of any space.

2017

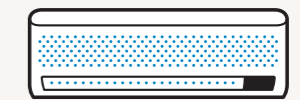

Samsung Wind-Free™ technology comes onto the market, gently and evenly dispersing fresh air through thousands of micro-holes to limit cold drafts.

Wind-Free™

Wind-Free™ Cooling

SmartThings

Wi-Fi Control

b.IoT

Building Management System

Our flagship technologies that enrich people's lives

Our European footprint with the locations from which we operate

- 1 | Samsung Electronics Air Conditioner Europe B.V.
- 16 | Samsung offices
- 8 | Warehouses
- 9 | Training centres



Samsung reference projects in the spotlight

Greenwood Fish Market



Cara Loh

Marketing Manager

Greenwood Fish Market, Singapore

Greenwood Fish Market
Block, 8D Dempsey Rd, #01-01, Singapore

“Greenwood Fish Market is located on Dempsey Hill and has glass walls on both sides that provide a beautiful view. People love it due to the feeling that they’re eating their meal surrounded by nature. However, because more solar heat comes in during the daytime, much more powerful air conditioning is necessary to keep the indoor room temperature pleasant. Samsung has provided us with the optimal solution. The 4-Way Cassette and 360 Cassette, which emit more air without the interference of blades, are installed in the perfect locations in the retail, dining and waiting zones, creating pleasant indoor conditions at all times. We are very satisfied.”

Application



Restaurant

Samsung products installed



360 Cassette



4-Way Cassette



Duct



CAC outdoor unit

Samsung reference projects in the spotlight

Kapiolani Residence



Timothy Yi
President

Kapiolani Residence
1391 Kapiolani Blvd #104, Honolulu, HI 96814, USA

“Kapiolani Residence is a large residential building with 45 floors and 485 households, located in the centre of Honolulu. We provide a refrigerator, washing machine, microwave oven and oven as a standard service for the convenience of the residents. All of the appliances are made by Samsung. Samsung is the best in the industry for air conditioning systems and general home appliances. It’s the only company to have succeeded in both industries. The greatest benefit for me in buying all of the products as a package from the same manufacturer is that I can talk to just one contact person for cost negotiation and product installation. And residents also benefit from an easy maintenance process.”

Application



Apartment

Samsung products installed



Wall-Mounted



Duct



FJM outdoor unit



RAC outdoor unit

Regulations and standards



Samsung strives to provide customers with new eco-friendly experiences and lead the way to a sustainable future for the global community through innovative and eco-friendly products and technology. We endeavour to comply with international environmental standards, and European and national laws and regulations across our climate solutions operations. Samsung also conducts environmental improvement activities across all product development, production, distribution, use and disposal phases.

Ecodesign

The Ecodesign Directive for Energy Related Products (ErP) aims to raise awareness about the energy efficiency of products, while encouraging manufacturers to make their products more energy efficient from the design phase. The Directive is applicable to a broad range of cooling and heating products, which have been divided into different lots.

LOT 10 was implemented on 1 January 2013 and covers air conditioners with a capacity less than 12 kW; typically residential or light commercial systems. It requires manufacturers to provide highly visible information regarding energy efficiency, including an energy label.

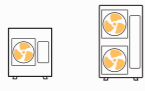
LOT 1 and 2 took effect on 26 September 2015 and include residential air to water heat pumps for space heating and hot water production respectively (< 400 kW). It is mandatory to provide energy labels for products with a capacity lower than 70 kW. On 1 January 2018, LOT 21 came into force. LOT 21 covers commercial cooling and heating products with a capacity greater than 12 kW. It does not require manufacturers to publish energy labels, but energy performance data should be made available online.

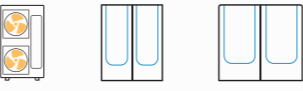
	LOTS 1/2	LOT 10	LOT 21
In effect since	26 September 2015	1 January 2013	1 January 2018
Applicable products	A2W heat pumps < 400 kW	Air conditioners < 12 kW	Air conditioners > 12 kW
Energy label required	✓	✓	
Samsung product range	 EHS	 RAC FJM CAC	 CAC DVM HVM

Energy label

Since January 2013, all air conditioners with a rated capacity of < 12 kW for cooling or heating must bear an energy label indicating their energy efficiency in compliance with EU Regulation No. 626/2011 (LOT 10). As of January 2019, the energy efficiency scale ranges from A+++ to D, with A+++ being the most efficient. The energy label should provide the minimum necessary

information such as the product model, energy efficiency class, average annual energy consumption, SEER/SCOP values and noise level. The energy efficiency class is determined by measurements and calculations and should fall within the ranges indicated in the table below.

Energy Efficiency Class	SEER (Cooling)	SCOP (Heating)
A+++	SEER ≥ 8.50	SCOP ≥ 5.10
A++	6.10 ≤ SEER < 8.50	4.60 ≤ SCOP < 5.10
A+	5.60 ≤ SEER < 6.10	4.00 ≤ SCOP < 4.60
A	5.10 ≤ SEER < 5.60	3.40 ≤ SCOP < 4.00
B	4.60 ≤ SEER < 5.10	3.10 ≤ SCOP < 3.40
C	4.10 ≤ SEER < 4.60	2.80 ≤ SCOP < 3.10
D	3.60 ≤ SEER < 4.10	2.50 ≤ SCOP < 2.80

Except single duct and double duct air conditioners.

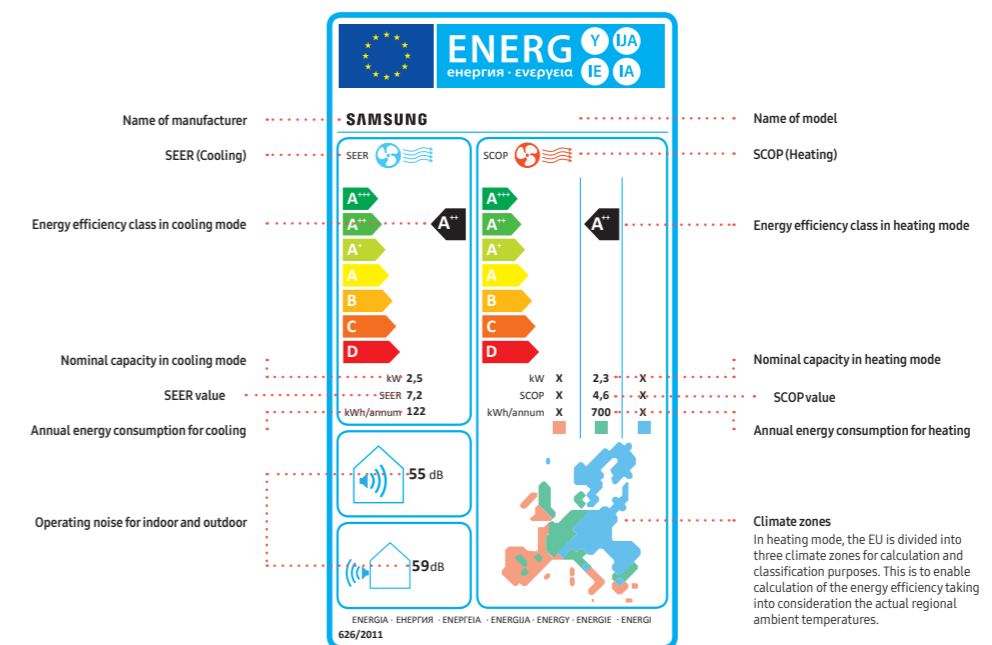

F-Gas regulation

The EU aims to reduce the environmental impact of F-gases through the reduction of the CO₂ equivalent consumption of HFCs (hydrofluorocarbons). EU regulation 517/2014 prescribes a phase-down of HFCs, where the quantities of HFCs that are placed on the market are gradually reduced through the allocation of quotas by the European Commission. The phase-down targets are expressed in CO₂ equivalents (= kg x GWP - Global Warming Potential) and aim to reduce HFC

consumption by 79 % in 2030. For new installations of single split air conditioners with a refrigerant charge below 3 kg, the GWP limit is set at 750 starting in 2025. The regulation has been put into force to encourage industry and users to transition to refrigerants with a lower GWP. Samsung is accelerating the transition towards lower GWP refrigerants, such as R32, and will continue to invest in environmentally friendly alternatives.

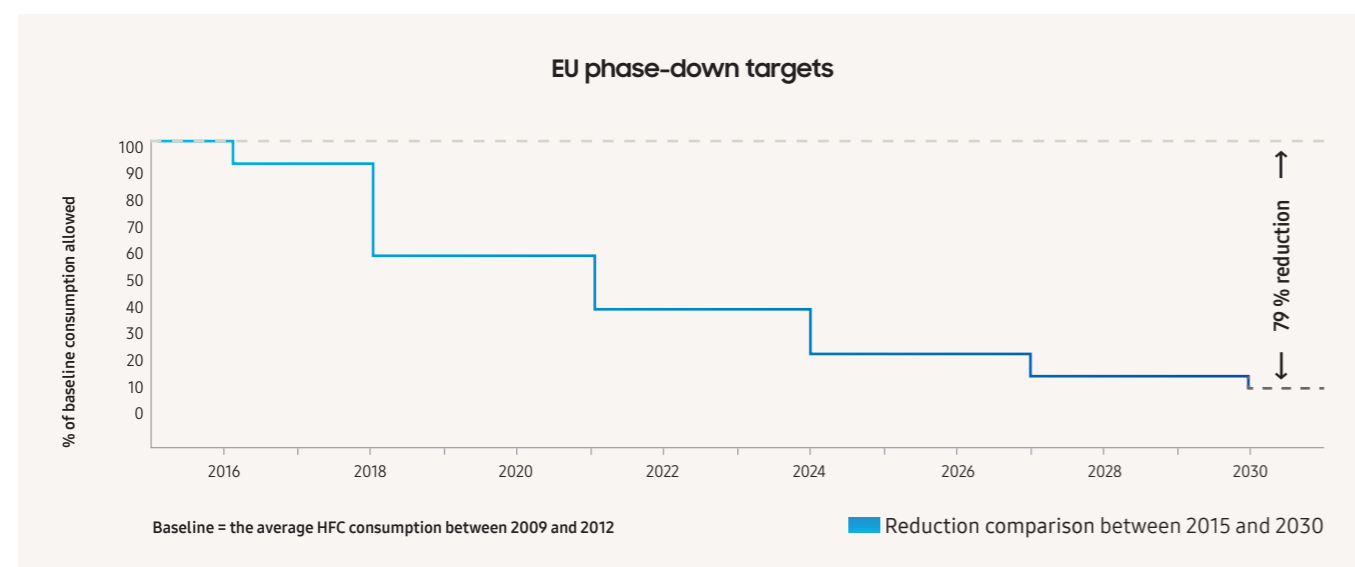

R32 Refrigerant

R32 refrigerant contributes to meeting the F-gas regulation targets as described in EU regulation 517/2014. Air conditioners with R32 refrigerant have a Global Warming Potential (GWP) of 675, which is significantly lower than the GWP of R410A (2088). While refrigerants are an essential part of today's air conditioners, R32 would have a 68 % lower environmental impact¹ than R410A, if leaked into the atmosphere. It has an Ozone Depletion Potential (ODP) of zero, and a high refrigeration capacity and thermal conductivity, meaning high efficiency and a reduction in charging volume. Samsung's single split Residential (RAC), Multi Split (FJM) and Commercial (CAC) product ranges up to 12 kW all feature R32 refrigerant.

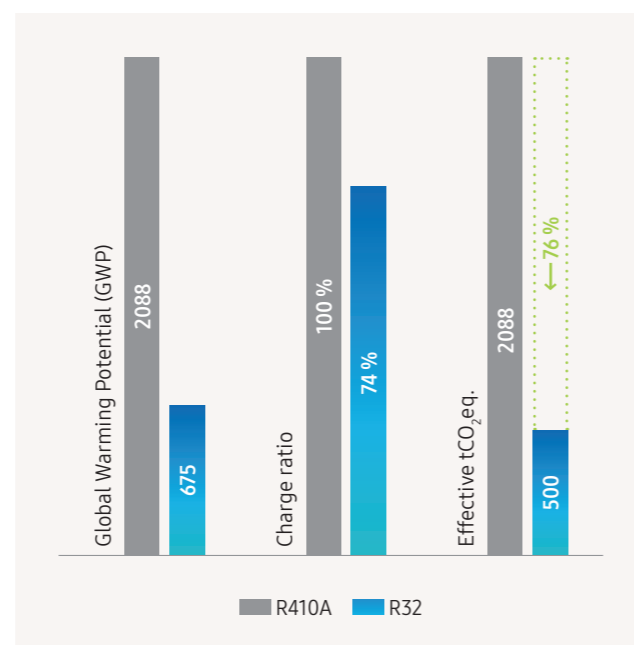

¹ Comparison between R410A and R32 GWP. Source: European Commission.



WEEE: Electronic Waste

Samsung adheres to the WEEE (Waste Electrical and Electronic Equipment) Directive, which applies the principles of extended producer responsibility. This Directive stipulates the safe collection, treatment, recycling and environmentally sound disposal of all electrical and electronic equipment. Working with collective recycling schemes in each EU member state, Samsung co-finances the take-back and recycling of electronic products.

Batteries

Samsung has been giving new life to used batteries by funding collection, treatment and recycling by local battery recycling organisations.

Packaging

Samsung works together with recycling schemes and governmental organisations to collect, separate and reuse all packaging materials at various points in the distribution chain. Many materials can be recycled into new products and recycling helps to save natural resources. Recycling packaging helps to reuse valuable raw materials and to reduce the overall impact on the environment.

Innovations in detail

Wall-Mounted

Fast Cooling

Samsung wall-mounted air conditioners with Wind-Free™ technology cool quickly from corner to corner, making people comfortable whenever they want and wherever they are. Powerboost with Digital Inverter TT (Twin Tube) technology dramatically shortens the time it takes for the compressor to reach maximum power when it starts operating, so it cools the air 43 % faster¹. Its advanced design also features a 15 % larger fan, 18 % wider inlet and a 31 % wider blade than conventional models. This means that cool air is dispersed farther and wider into every corner of a room, reaching up to 15 metres².

¹ Tested on the AR12TXCAAWKEU model compared with the Samsung conventional model AQ12EASER under specific testing conditions and may vary depending on environmental factors and use.

² Tested on the AR24TXFCAWKNEU model under specific testing conditions and may vary depending on environmental factors and use.

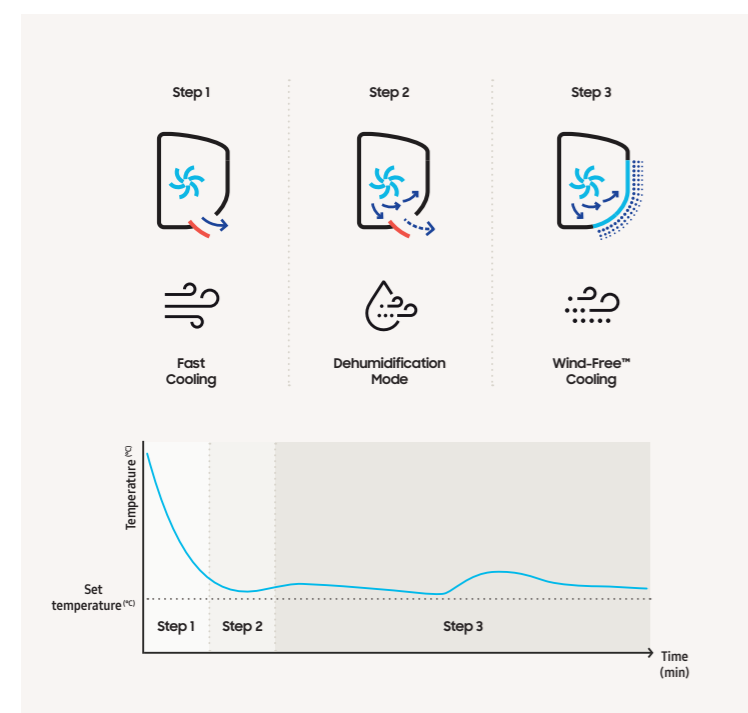
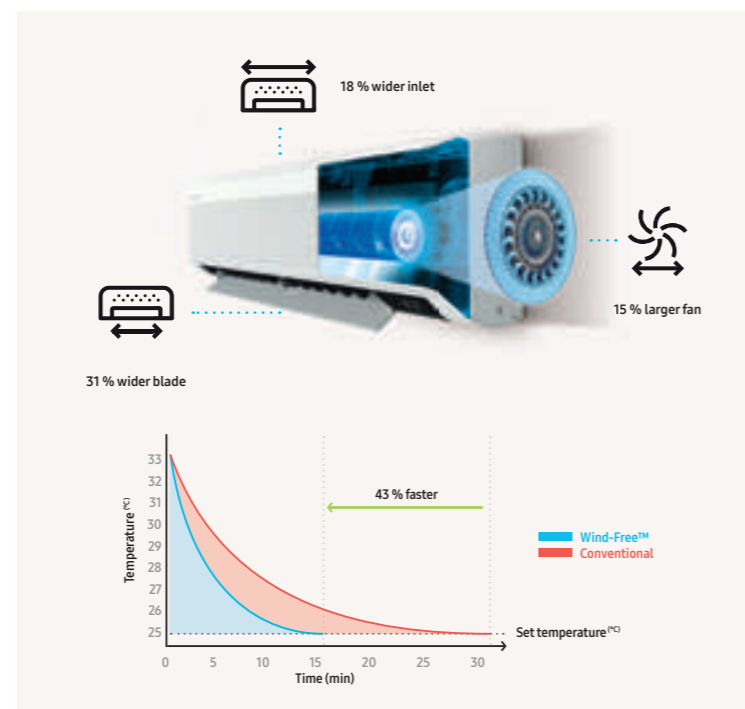

Wind-Free™ Cooling

Wind-Free™ Cooling mode keeps the room comfortably cool. It cools gently and quietly, dispersing air through 23,000 micro-holes so that people never have to deal with the unpleasant feeling of a cold draft on their skin. This results in a "Still Air" environment¹ with a very low air speed and limited noise². The advanced airflow structure of this mode also means that it cools a wider and larger area more evenly. And it consumes 77 % less energy than Fast Cooling mode³ so people can stay comfortably cool while reducing energy costs.

¹ ASHRAE (the American Society of Heating, Refrigerating, and Air-Conditioning Engineers) defines "Still Air" as air currents moving at speeds below 0.15 m/s, with no cold drafts.

² Tested on the AR12TXCAAWKNEU model in an anechoic environment. Wind-Free™ mode generates 23 dB(A) of noise, compared to 26 dB(A) produced by the conventional Samsung model. Sound pressure level is a relative value, depending on the distance and acoustic environment. Sound pressure level may differ according to operating conditions.

³ Tested on the AR12TVEAAWKNEU model under specific testing conditions, based on the power consumption of Fast Cooling mode vs. Wind-Free™ Cooling mode.



AI Auto Comfort

AI Auto Comfort introduces residents to the experience of intelligent climate control¹. To make life simpler and more efficient, it automatically optimises the various modes by analysing room conditions and usage patterns². Based on users' preferred temperature and the outside temperature, it automatically switches to the most appropriate mode, including Wind-Free™, Fast and Normal Cooling, to maintain optimal, comfortable room conditions.

¹ AI = Artificial Intelligence. A Wi-Fi connection and Samsung SmartThings application account are required.

² Stores user data, preferences and usage patterns, enabling it to suggest the most useful options.

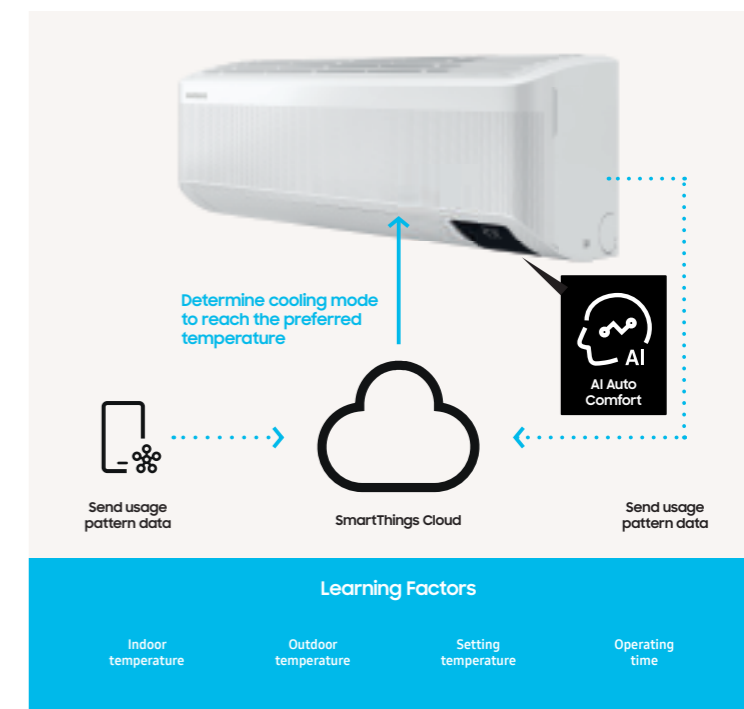

Smart Control

Control the temperature at home, anytime and anywhere. The SmartThings App¹ enables people to remotely control their air conditioner. With just the touch of a button, users can turn the air conditioner on or off, select the cooling mode, schedule the air conditioner's operation and monitor its power consumption. And with the Bixby 2.0 Artificial Intelligence (AI) system¹, a user can simply tell the device what they want², and the device carries out their wishes. It even analyses the environment, preferred mode and temperature and suggests the best settings for inside the home.

¹ Available on Android and iOS devices. A Wi-Fi connection and Samsung SmartThings account are required.

² Voice control is supported in English (US, UK, Indian), Chinese, Korean, French, German, Italian and Spanish. Portuguese is scheduled to be supported by the end of 2019.

Innovations in detail

Wall-Mounted

Motion Detect Sensor

Cool the home efficiently whether someone is there or not. If the Motion Detect Sensor (MDS) detects a lack of movement after 20 minutes¹, it automatically switches to Wind-Free™ mode to save energy. Subject to conditions, after 40 minutes it increases the temperature by 2 °C in Wind-Free™ mode. And after a further 40 minutes it enters standby (Soft off) mode. But as soon as it detects any activity it returns to working normally. It can also be set to avoid blowing air towards people, or alternatively, to follow them as they move around.

¹ The Motion Detect Sensor (MDS) starts detecting the absence of movement after a minimum of five minutes and up to a maximum of 60 minutes.



Step 1: Easy Filter Plus

Keep the air conditioner working efficiently with limited effort. Unlike conventional filters that may be difficult to access, the Easy Filter Plus is located externally, on the top of the unit. This means it can be easily removed and cleaned, without needing to open a cover or pull hard on it. Thanks to the filter's dense mesh, it's very effective at capturing dust and therefore keeping the Heat Exchanger clean and working efficiently. The special coating on the filter helps protect residents from airborne contaminants¹.

¹ Tested in Korean test lab (FITI). Data has been measured under specific testing conditions and may vary depending on environmental factors and individual use.

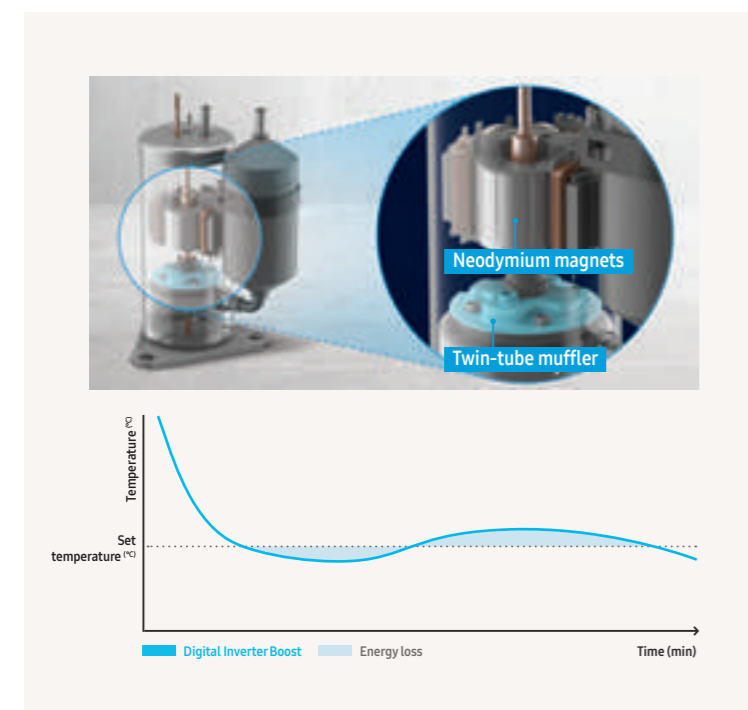
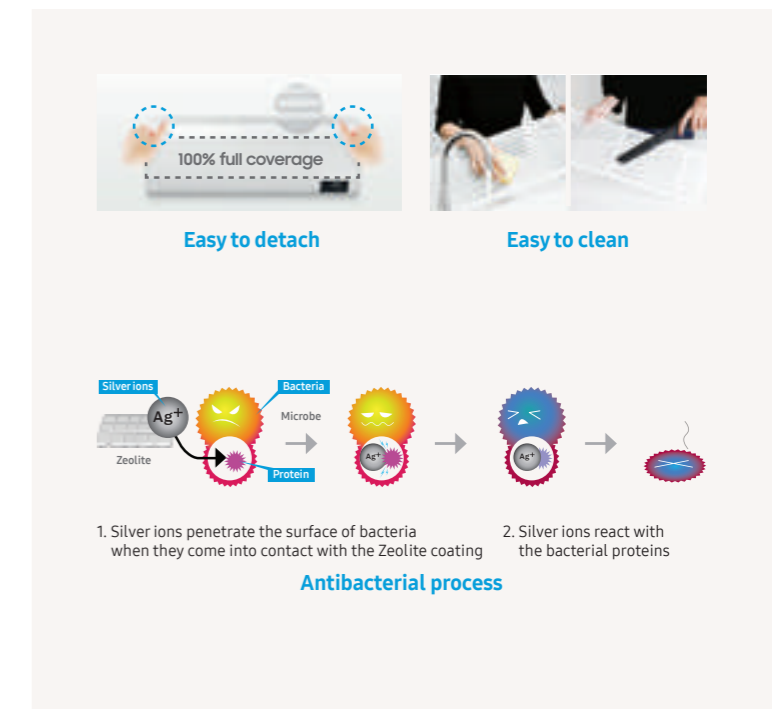

Digital Inverter Boost

Samsung's compressor with Digital Inverter Boost technology helps to save on energy consumption. Unlike conventional fixed-speed compressors, it maintains the desired temperature without frequently turning off and on, resulting in less fluctuation. As it's equipped with strong neodymium magnets and a muffler, it works efficiently and produces less noise and vibration than conventional models. When cooling, it optimises power usage and therefore reduces energy consumption by up to 5 %¹.

¹ Tested on the AR09TXCAAWKNEU model compared with the previous Samsung Wind-Free™ model AR09NXXCAWKNEU.



Step 2: Tri-Care Filter

The Tri-Care Filter keeps the air hygienic and sustains the performance of the Heat Exchanger. Its three layers include a high-density filter that extracts large household dust particles, fibres and animal hairs. It also has a filter with Zeolite coating that captures fine dust, and helps to reduce potentially dangerous viruses, bacteria and allergens in the air¹.

¹ Tested by Korean test lab (FITI/KRICT) for anti-bacteria and anti-virus properties, and by Japanese test lab (ITEA) for anti-allergy properties. Data has been measured under specific testing conditions and may vary depending on environmental factors and individual use. Tested on AR13TYCABWKNST model.

Innovations in detail

360 Cassette

Circular airflow

Unlike traditional 4-Way cassette units¹, which create areas of uneven airflow², the 360 Cassette ensures that cool air reaches every single corner. Its circular outlet blows cool air in every direction. The bladeless design keeps things comfortably cool without creating a cold draft³, and without blades blocking the airflow, it sends 25 % more air even further¹.

¹ Samsung testing compares the 360 Cassette to a conventional 4-Way cassette type air conditioner.
² The temperature difference is less than 0.6 °C within a 9.3 m radius.
³ No cold draft between 0–1.5 m in height (with a 14.0 kW indoor unit) within a 5 m radius.

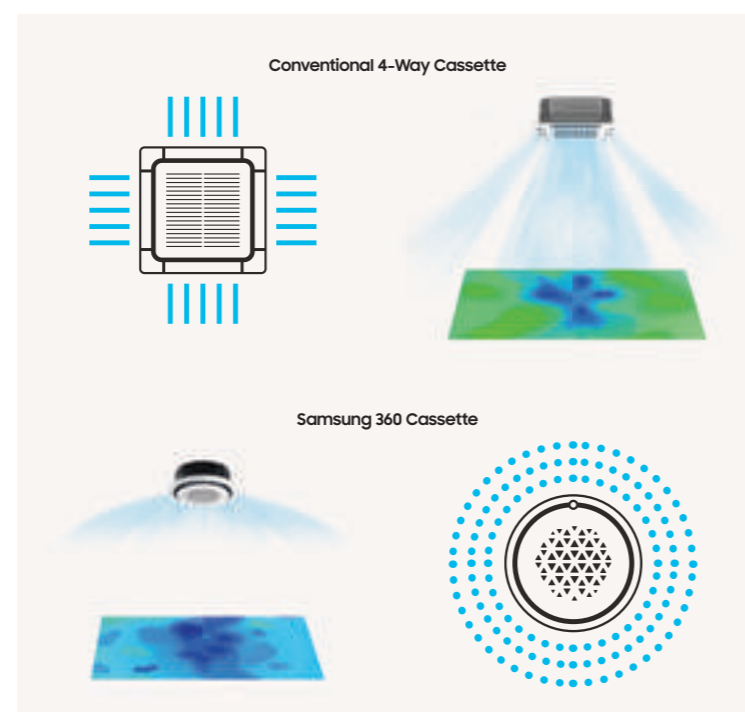

LED display

The unit features a stylish panel and an intuitive LED display. This allows users to choose and change the direction of airflow. Users have a choice of settings, and controlling the air in an individual zone is easy.

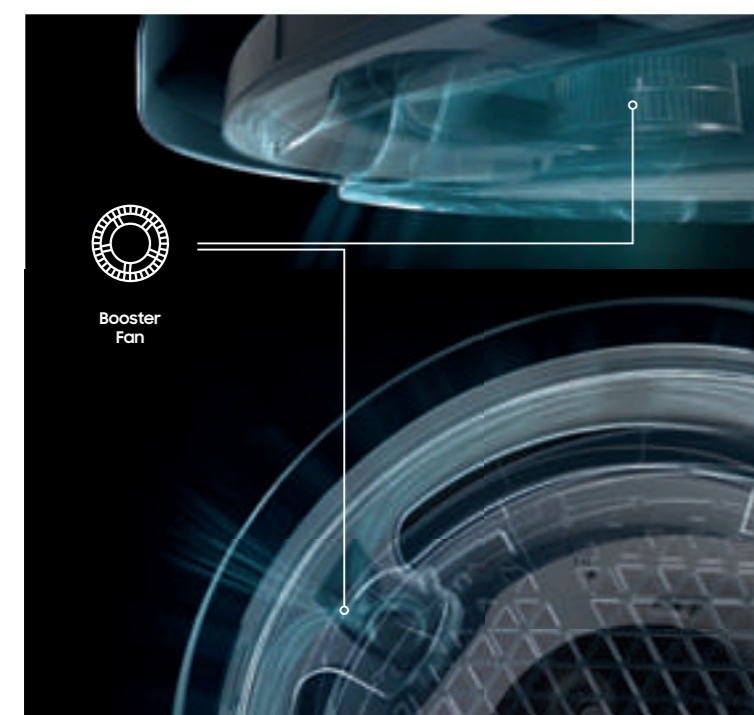

Airflow control

The air supply is easily adjusted without the use of flaps. Three booster fans alter the direction of airflow from within the cassette's hollow space. A rain-like distribution of air (known as the 'Coandă' effect) keeps the room cool and comfortable at all times.



Stylish design

The 360 Cassette adds a touch of style to any room. It comes in black or white, in a square or circular design, and can be fitted into the ceiling or exposed on the surface of any material. It suits any type of background, from wood to concrete and wallpaper to paint.

Innovations in detail

Wind-Free™ 4-Way Cassette

Wind-Free™ technology

Wind-Free™ Cooling is some of Samsung's most advanced technology. The Wind-Free™ 4-Way Cassette directs air through 15,700 micro-holes in the panel, while the Wind-Free™ Mini 4-Way Cassette directs air through 9,000 micro-holes in the panel. These micro-holes are essential for creating a type of airflow called "Still Air", which cools the room gradually and noticeably without drafts.

¹ASHRAE (the American Society of Heating, Refrigeration, and Air-Conditioning Engineers) defines "Still Air" as air currents moving at speeds below 0.15 m/s, with no cold drafts.

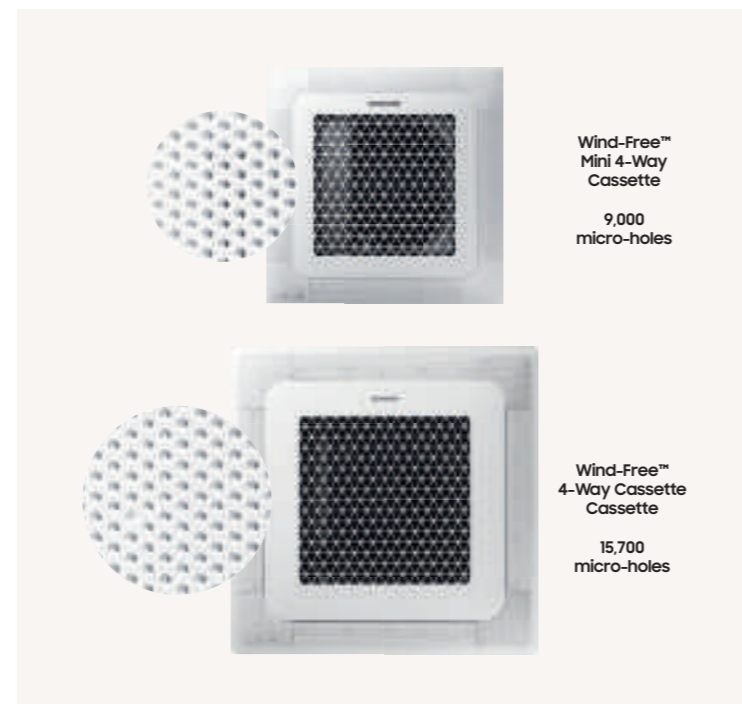

Optimised blades

The larger, optimised blades¹ (84 mm Wind-Free™ 4-Way Cassette, 66 mm Wind-Free™ Mini 4-Way Cassette) facilitate a wider cooling range and improved air circulation within the room. This advanced technology also cools the space much faster, leaving no zone untouched.

¹Samsung testing compares the Wind-Free™ 4-Way and Mini 4-Way Cassette to a conventional 4-Way Cassette type air conditioner.

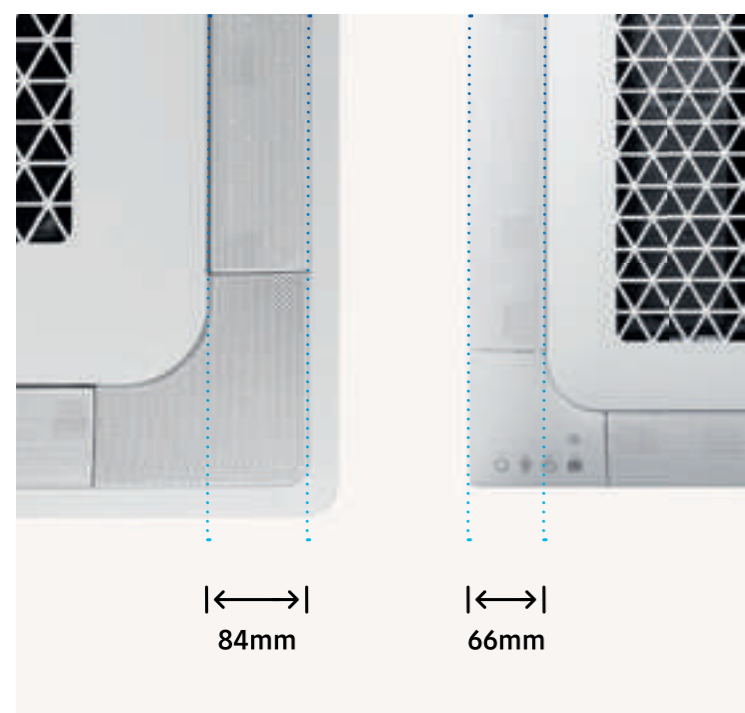

Optimised blades

The larger, optimised blades¹ (84 mm Wind-Free™ 4-Way Cassette, 66 mm Wind-Free™ Mini 4-Way Cassette) facilitate a wider cooling range and improved air circulation within the room. This advanced technology also cools the space much faster, leaving no zone untouched.

¹Samsung testing compares the Wind-Free™ 4-Way and Mini 4-Way Cassette to a conventional 4-Way Cassette type air conditioner.

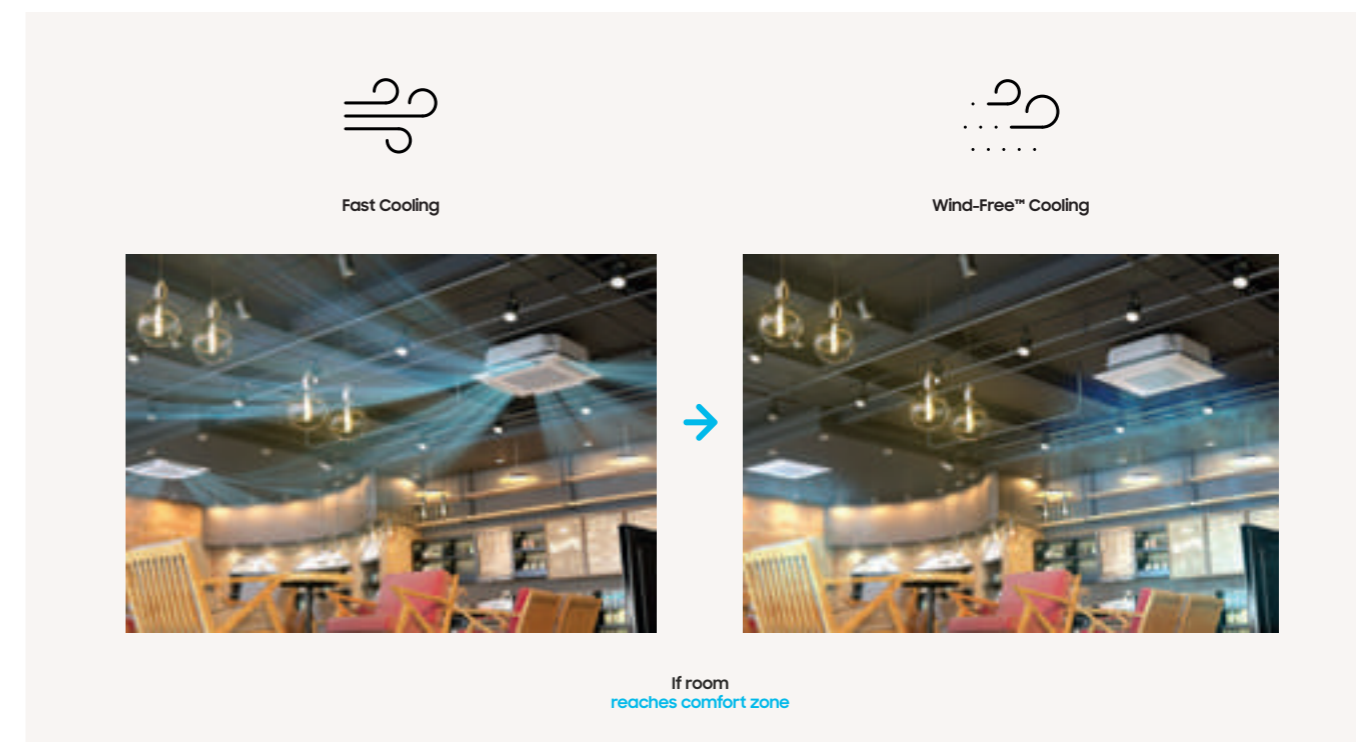

Smart Comfort Operation

The Wind-Free™ 4-Way Cassette and the Wind-Free™ Mini 4-Way Cassette boast Smart Comfort Operation. The Fast Cooling process helps to achieve the desired temperature in a room quickly. By simultaneously detecting the humidity levels, the Smart Comfort Operation feature maintains the room's temperature automatically.

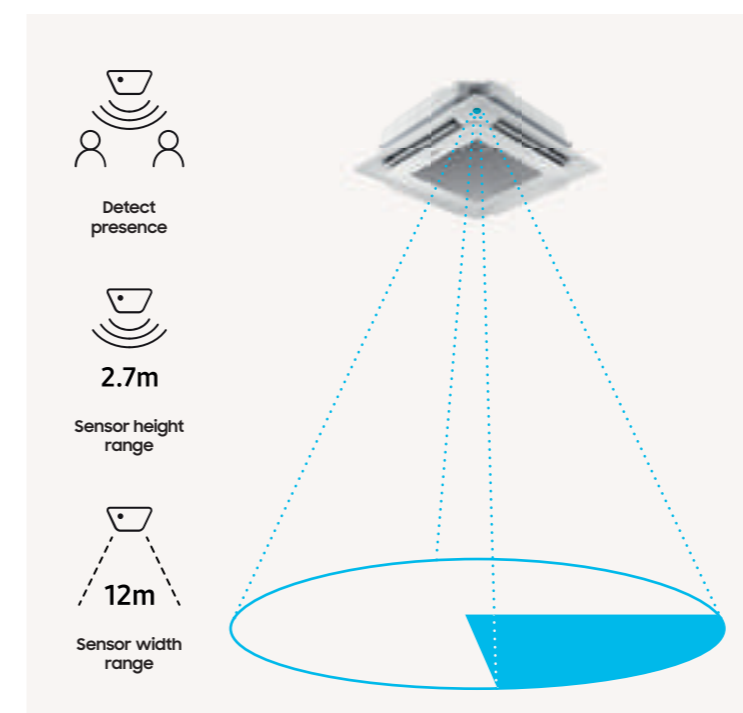

Motion Detect Sensor (optional)

The improved Motion Detect Sensor (MDS) detects the presence and location of people in the room, enabling automatic management of airflow direction and efficient air cooling.

Innovations in detail



Wind-Free™ 1-Way Cassette

Wind-Free™ technology

Wind-Free™ Cooling is some of Samsung's most advanced technology. The Wind-Free™ 1-Way Cassette directs air through tiny holes in the panel, dispersing a gentle flow of air. These 13,000 micro-holes are essential for creating a type of airflow called "Still Air"¹, which cools the room gradually and noticeably without drafts.

¹ASHRAE (the American Society of Heating, Refrigeration, and Air-Conditioning Engineers) defines "Still Air" as air currents moving at speeds below 0.15 m/s, with no cold drafts.



Slim installation/small footprint

At a height of only 152 mm¹, the Wind-Free™ 1-Way Cassette is a compact and lightweight device (8–13.5 kg²). This slim design makes it not only visually pleasing, but also easier to install and maintain, and it can be fitted into small gaps or ceilings.

¹Up to 3.6 kW, larger models measure 155 mm.

²1.7 kW and 2.2 kW models weigh 8 kg. The 5.6 kW and 7.1 kW models weigh 13.5 kg.

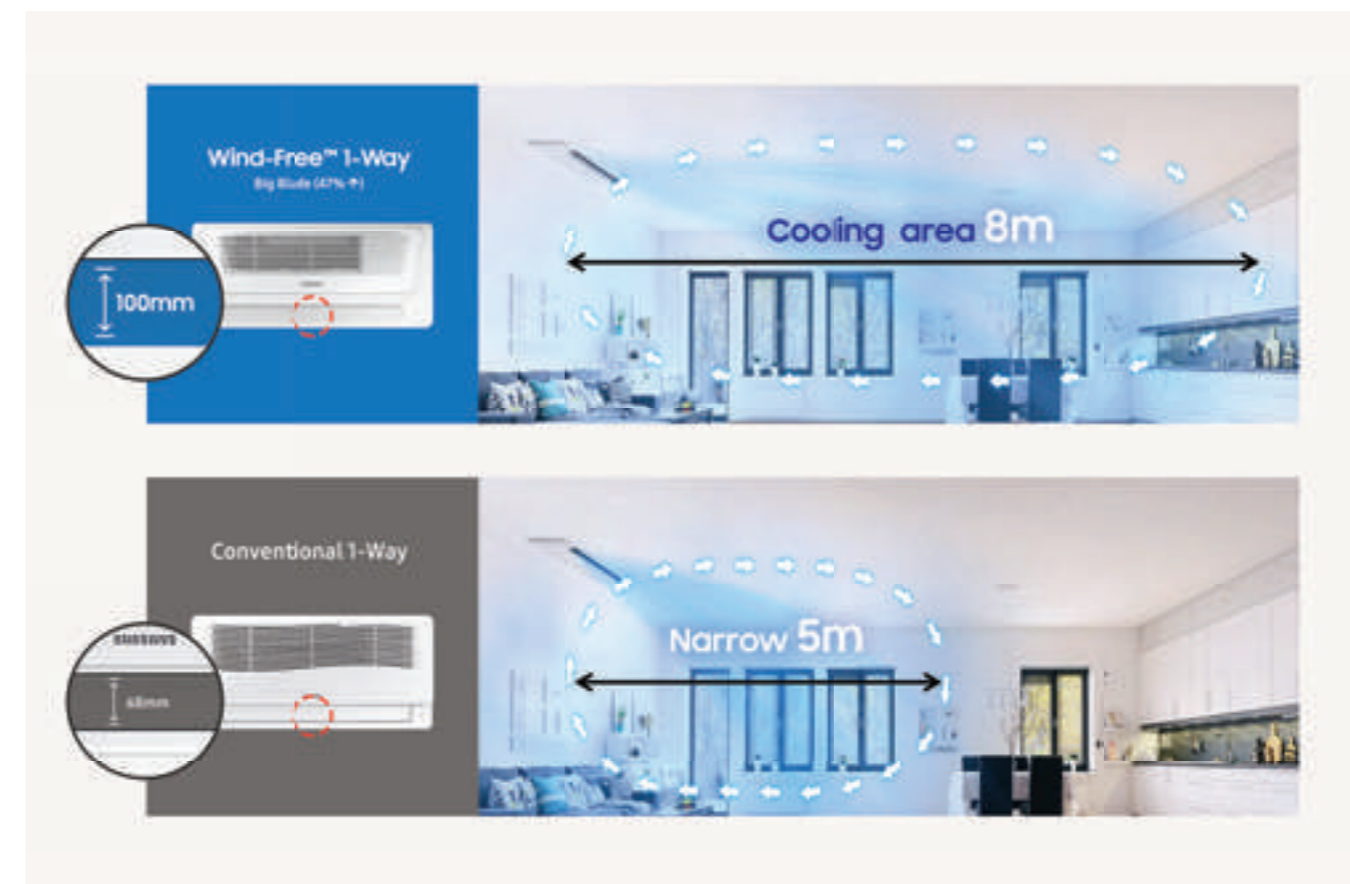

Wider cooling range

The larger, optimised blade¹ works to cool a larger area much faster. Its sleek design can deliver cool air efficiently, rapidly and evenly over an area of up to 8 m², leaving no zone untouched.

¹Samsung testing compares the Wind-Free™ 1-Way Cassette to a conventional 1-Way Cassette-type air conditioner.
²Based on the 7.1 kW indoor unit.

Innovations in detail



Duct S

Flat microchannel heat evaporator/condenser

Samsung's innovative FME/FMC technology provides increased efficiency compared with the conventional fin and tube type. These modern innovations have also enabled a reduction in the size of the unit.

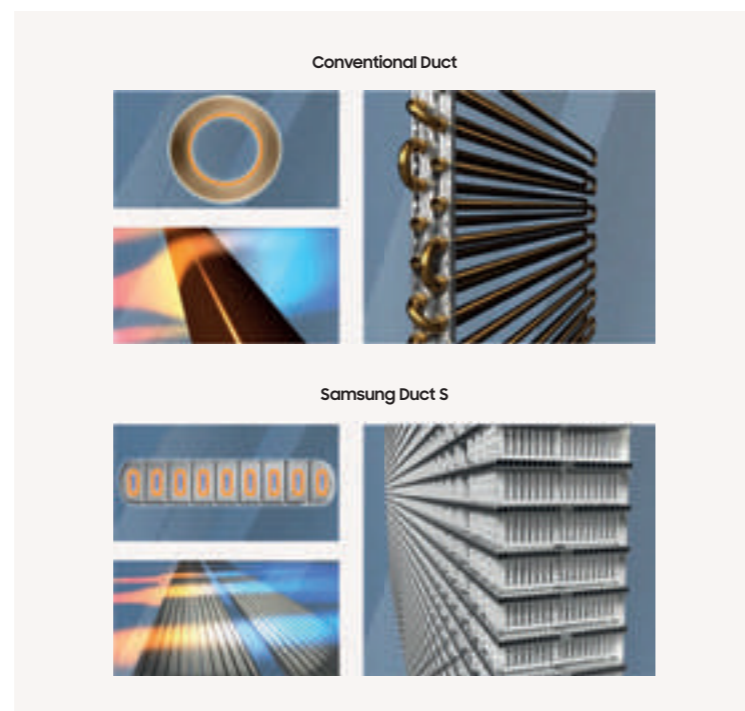

Indoor discharge temperature

Each ducted indoor unit, or AHU kit, boasts a discharge air temperature control function that offers greater comfort without the need to change the outdoor unit setting. Cooling and heating options can be selected using a remote control, and this applies to all ducted/AHU connected systems.



Easy installation and maintenance

Thanks to their ultra-compact design, Samsung duct units can be placed anywhere and can even be split into two parts (20/25 kW models). This makes for easy installation and maintenance. The indoor unit can be accessed from three directions: from the top, bottom and one side, making maintenance simpler than ever.

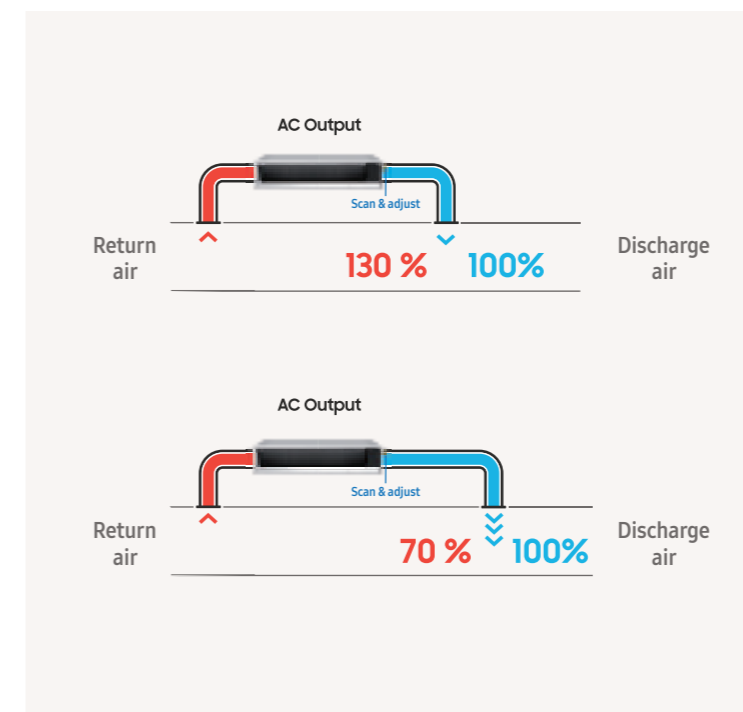

Automatic ESP setting

The automatic operation of the external static pressure feature is very simple to set up.

This auto setting enables you to choose the optimal operating range for the fan. The result is the greatest possible comfort with an optimal balance between sound level and capacity. Please contact your Samsung representative to find out which indoor units feature this function.

Innovations in detail

Slim Duct S

Slim design for small ceiling spaces

The Slim Duct S is a slim 200 mm in width, making it much narrower than conventional products. This allows for easy installation and maintenance in all kinds of spaces.

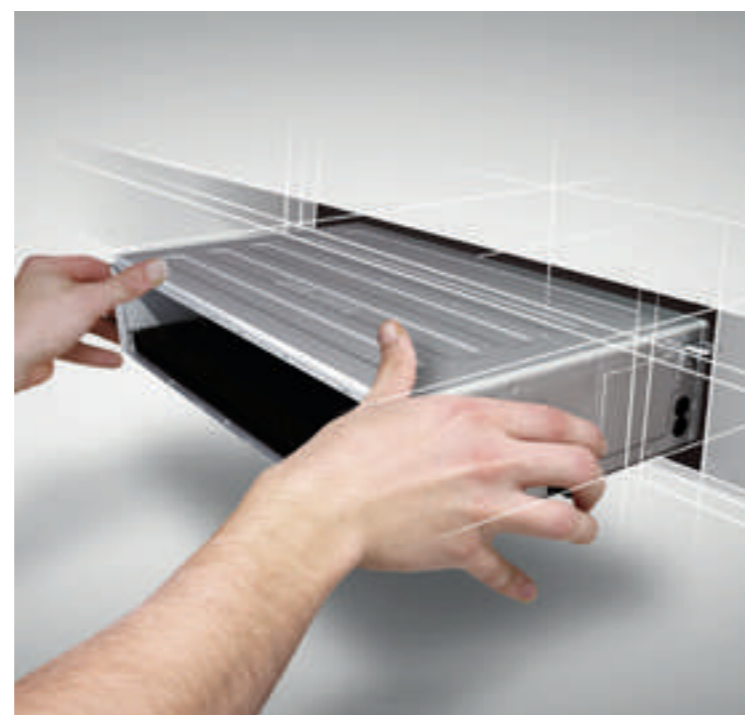

Built-in drain pump







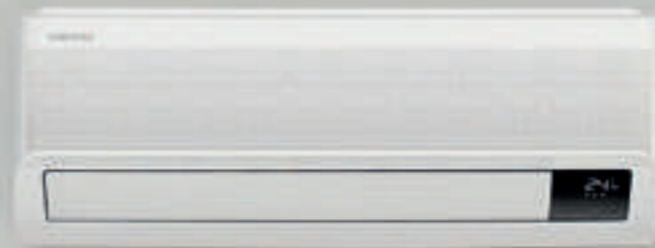











A check valve on the drain pump prevents drained water from flowing back into the drain pan, minimising the water level in the drain pan. This modern design feature means no water stagnation, and prevents drain water overflowing into your interiors.



Residential



Line-up

Model	Indoor Unit	Outdoor unit (2.5 kW & 3.5 kW)	2.5 kW	3.5 kW	Outdoor unit (5.2 kW & 6.8 kW)	5.2 kW	6.8 kW
Wind-Free™ Elite			•	•			
Wind-Free™ Avant			•	•		•	•
Wind-Free™ Comfort			•	•		•	•
Cebu			•	•		•	•
Luzon			•	•		•	•
AR35			•	•		•	•
AR30			•	•			

Range	Indoor Unit	Outdoor unit (2.5 kW & 3.5 kW)	2.5 kW	3.5 kW
Nordic Smart			•	•
Nordic Comfort			•	•



Selection guide

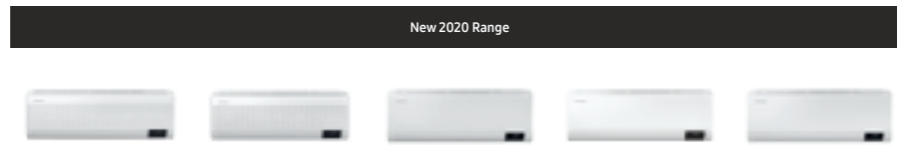

Model	Wind-Free™ Elite	Wind-Free™ Avant	Wind-Free™ Comfort	Cebu	Luzon
Energy Efficiency	A+++ A+++		A++ A++	A++ A+	A++ A+
Certification	Eurovent				
Airflow	Wind-Free™ Cooling	•	•	•	•
	Air Direction Control (Up/Down)	Auto	Auto	Auto	Auto
	Air Direction Control (Left/Right)	Auto	Auto	Manual	Manual
	Airflow Control Step (Cool/Fan)	5/4	5/4	5/4	5/4
	Auto Fan Speed	•	•	•	•
Air Purification	PM 10 Filter	•	•	•	•
	Easy Filter Plus/HD Filter	•	•	•	•
	Tri-Care Filter	•	•	•	•
	Allergy Care	•	•	•	•
	Anti-Bacteria Coating	•	•	•	•
	Anti-Virus Coating	•	•	•	•
	Auto Clean (Self-Cleaning)	•	•	•	•
Functions	Samsung SmartThings	•	•	•	•
	Smart Operation (AI)	•	•	•	•
	MDS (Motion Detect Sensor)	•	•	•	•
	Filter Cleaning Indicator	•	•	•	•
	Indoor Temperature Display	•	•	•	•
	Voice Control with Bixby	•	•	•	•
	Display On/Off 88 Display	•	•	•	•
	Beep On/Off	•	•	•	•
	24-Hour Timer/Real Timer	•	•	•	•
	Auto Changeover	•	•	•	•
	Auto Restart	•	•	•	•
Operating Mode	AI Auto Comfort with Wi-Fi & MDS (direct/indirect)	•	•	•	•
	AI Auto Comfort with Wi-Fi	•	•	•	•
	Auto Mode (without Wi-Fi)	•	•	•	•
	Fast Cooling	•	•	•	•
	Good Sleep	•	•	•	•
	Eco	•	•	•	•
	Dehumidification	•	•	•	•
	Fan	•	•	•	•
	Quiet	•	•	•	•
Triple Protector	Anti-Corrosion Fin	•	•	•	•
	Compressor Protector	•	•	•	•
	PBA Protector	•	•	•	•



Model	AR35	AR30
Energy Efficiency	A++ A+	A++ A+
Certification	Eurovent	
Airflow	Wind-Free™ Cooling	•
	Air Direction Control (Up/Down)	Auto
	Air Direction Control (Left/Right)	Manual
	Airflow Control Step (Cool/Fan)	3/3
	Auto Fan Speed	•
Air Purification	PM 10 Filter	•
	Easy Filter Plus/HD Filter	•
	Tri-Care Filter	•
	Allergy Care	•
	Anti-Bacteria Coating	•
	Anti-Virus Coating	•
	Auto Clean (Self-Cleaning)	•
Functions	Samsung SmartThings	•
	Smart Operation (AI)	•
	MDS (Motion Detect Sensor)	•
	Filter Cleaning Indicator	•
	Indoor Temperature Display	•
	Voice Control with Bixby	•
	Display On/Off 88 Display	•
	Beep On/Off	•
	24-Hour Timer/Real Timer	•
	Auto Changeover	•
	Auto Restart	•
Operating Mode	AI Auto Comfort with Wi-Fi & MDS (direct/indirect)	•
	AI Auto Comfort with Wi-Fi	•
	Auto Mode (without Wi-Fi)	•
	Fast Cooling	•
	Good Sleep	•
	Eco	•
	Dehumidification	•
	Fan	•
	Quiet	•
Triple Protector	Anti-Corrosion Fin	•
	Compressor Protector	•
	PBA Protector	•

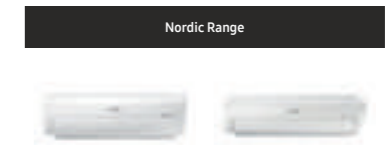

Model	Smart	Comfort
Energy Efficiency	A+++ A++	rtt++ A++
Certification	Eurovent	
Airflow	Wind-Free™ Cooling	•
	Triangle Technology	•
	Air Direction Control (Up/Down)	Auto
	Air Direction Control (Left/Right)	Auto
	Airflow Control Step (Cool/Fan)	5/4
	Auto Fan Speed	•
Air Purification	SPI Ioniser	•
	PM 2.5 Filter	•
	Easy Care Filter	•
	Tri-Care Filter	•
	Allergy Care	•
	Anti-Bacteria Coating	•
	Anti-Virus Coating	•
	Auto Clean (Self-Cleaning)	•
Functions	Wi-Fi Control with Samsung SmartThings	•
	Filter Cleaning Indicator	•
	Indoor Temperature Display	•
	Remote Controller	•
	Display On/Off 88 Display 88 LED	•
	3 LED Display	•
	Beep On/Off	•
	24-Hour Timer/Real Timer	24 Hr
	Auto Changeover	•
	Auto Restart	•
Operating Mode	2-Step Cooling	•
	Fast Cooling	•
	Comfort Cooling	•
	Good Sleep	•
	Single User	•
	Dehumidification	•
	Auto	•
	Fan	•
	Quiet	•
Triple Protector	Anti-Corrosion Fin	•
	Compressor Protector	•
	PBA Protector	•

¹ Energy labels as shown are based on 9k Btu versions and are according to EU No 626/2011 (LOT10) label classification 2019, on a scale from D to A+++.

Nomenclature

Residential Units

AR 12 T X E A A WK N EU

1 2 3 4 5 6 7 8 9

1	Classification	AR	Residential Air Conditioner (RAC)
2	Capacity		x1,000 Btu/h
3	Year	T	2020
4	Product Type	X	Inverter R32
5	Feature	C	MDS + Wi-Fi + Tri-Care Filter
		E	Wi-Fi +Tri-Care Filter
		F	Wi-Fi
		H	HD Filter
6	Design	A	Wind-Free™ Elite/Avant
		C	Wind-Free™ Comfort
		Y	Cebu
		Z	Luzon
		Q	AR
7	Series	A	First Series
		B	Second Series
8	Colour	WK	DA White
		SI	Shining White
9	Unit Type	N	Indoor Unit
		X	Outdoor Unit



Specifications

Wind-Free™ Elite R32

- Three-step cooling: Fast Cooling mode, Dehumidification mode and Wind-Free™ Cooling mode.
- Tri-Care Filter system with Zeolite Coating.
- AI Auto Comfort and Motion Detect Sensor.
- Wi-Fi Control with Samsung SmartThings and Bixby voice controls.
- Compressor with Digital Inverter Boost technology.
- Equipped with NASA communication protocol.
- Direct drive fan powered by a BLDC motor.
- Triple Protector Plus to protect compressor, fin and controller from power surges.



Indoor Unit			AR09TXCAAWKNEU	AR12TXCAAWKNEU
Outdoor Unit			AR09TXCAAWKXEU	AR12TXCAAWKXEU
Capacity				
Capacity	Cooling (Nominal)	kW	2.5	3.5
	Cooling (Min-Max)	kW	0.9-3.6	0.9-4.8
	Heating @ +7 °C	kW	3.2	4.0
	Heating (Min-Max)	kW	0.8-7.1	0.8-7.3
	Heating @ -5 °C	kW	4.15	4.83
	Heating @ -10 °C	kW	3.98	4.62
	Heating @ -15 °C	kW	3.92	4.52
Performance				
Energy Efficiency Cooling	SEER ¹	W/W	8.8/ A+++	8.5/ A+++
	Power Consumption	kWh/a	99	144
	Pdesignc	kW	2.5	3.5
	EER	W/W	4.63	3.95
Energy Efficiency Heating	SCOP ¹	W/W	5.1/ A+++	5.1/ A+++
	Power Consumption	kWh/a	631	659
	Pdesignh (average)	kW	2.3	2.4
	COP ¹	W/W	4.74	4.26
Moisture Removal		l/h	1.0	1.5
Maximum Airflow (Cooling)	Indoor Unit	m ³ /min	11.1	12.1
	Outdoor Unit	m ³ /min	45.0	45.0
Sound Power	Indoor Unit (Cooling)	dB(A)	56	58
	Outdoor Unit (Cooling)	dB(A)	59	62
Sound Pressure	Indoor Unit High/Silent Mode	dB(A)	39/16	40/16
	Outdoor Unit High	dB(A)	45	46
Operating Temperature Range	Cooling	°C	-10-46	-10-46
	Heating	°C	-15-24	-15-24
Electrical Data				
Power Source		Φ, V, Hz	1Φ, 220-240 V, 50 Hz	1Φ, 220-240 V, 50 Hz
Compressor Type	Outdoor Unit	Type	BLDC Rotary	BLDC Rotary
Power Consumption	Cooling	W	540	885
	Heating	W	675	940
Operating Current	Cooling	A	2.9	4.1
	Heating	A	3.4	4.4
Dimensions				
Net Dimensions (W x H x D)	Indoor Unit	mm	889 x 299 x 215	889 x 299 x 215
	Outdoor Unit	mm	790 x 548 x 285	790 x 548 x 285
Net Weight	Indoor Unit	kg	10.6	10.6
	Outdoor Unit	kg	32.5	32.5
Refrigerant				
Refrigerant	Type		R32 (contains fluorinated greenhouse gases. GWP = 675)	
	Charging (for 5 m)	kg	0.97	0.97
	Charging Ton Equivalent CO ₂	tCO ₂ e	0.65	0.65
	Additional Refrigerant Charging	g/m	15	15
Piping Connections	Liquid Pipe	ø, mm (inch)	6.35 (1/4)	6.35 (1/4)
	Gas Pipe	ø, mm (inch)	9.52 (3/8)	9.52 (3/8)
Piping Length	Min/Max (ODU to IDU)	m	3/15	3/15
Piping Height	Max	m	8	8
Piping Connections	Drain Pipe	ø, mm	ø16.3, 550 mm	ø16.3, 550 mm

Indoor Unit			AR09TXCAAWKNEU	AR12TXCAAWKNEU
Outdoor Unit			AR09TXCAAWKXEU	AR12TXCAAWKXEU
Functions				
Airflow	Wind-Free™ Cooling		●	●
	Air Direction Control (Up/Down)		Auto	Auto
	Air Direction Control (Left/Right)		Auto	Auto
	Auto Fan Speed		●	●
Air Purification	Tri-Care Filter		●	●
	Easy Filter Plus		●	●
	Auto Clean (Self-Cleaning)		●	●
Operating Mode	AI Auto Comfort with Wi-Fi & MDS (direct/indirect)		●	●
	AI Auto Comfort with Wi-Fi		●	●
	Auto Mode (without Wi-Fi)			
	Fast Cooling		●	●
	Good Sleep		●	●
	Eco		●	●
	Dehumidification		●	●
	Fan		●	●
	Quiet		●	●
	Other Functions	Samsung SmartThings		●
	MDS (Motion Detect Sensor)		●	●
	Indoor Temperature Display		●	●
	Display On/Off	88 Display	●	●
	Beep On/Off		●	●
	Auto Changeover		●	●
	Auto Restart		●	●

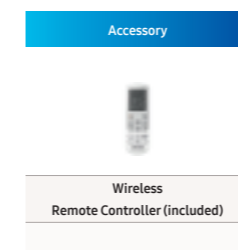

¹Energy labels as shown are according to EU No 626/2011 (LOT10) label classification 2019, on a scale from D to A+++.

Dimensional drawings

Wind-Free™ Elite - Indoor

AR09/12TXCAAWKNEU

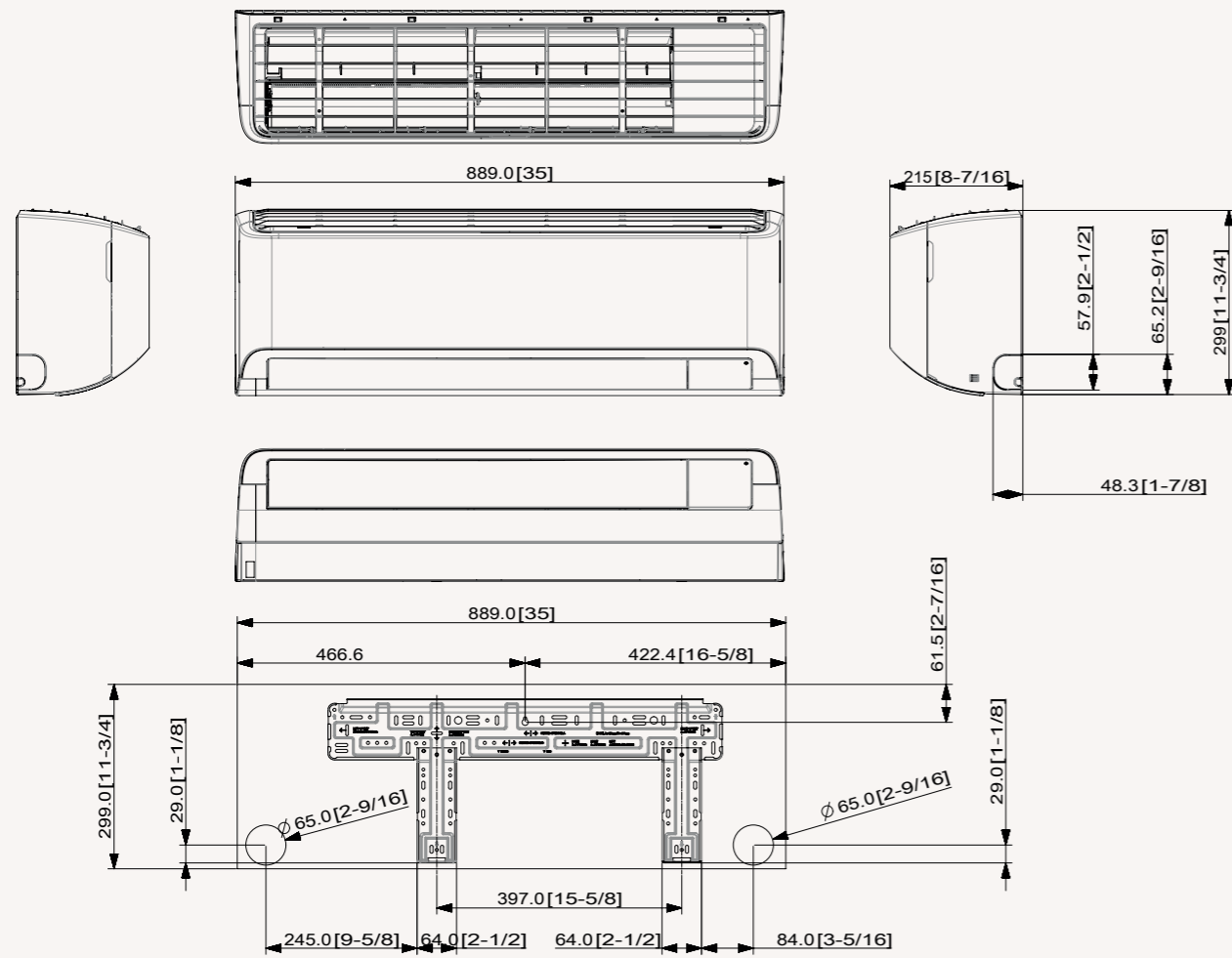

Wind-Free™ Elite - Outdoor

AR09/12TXCAAWKXEU

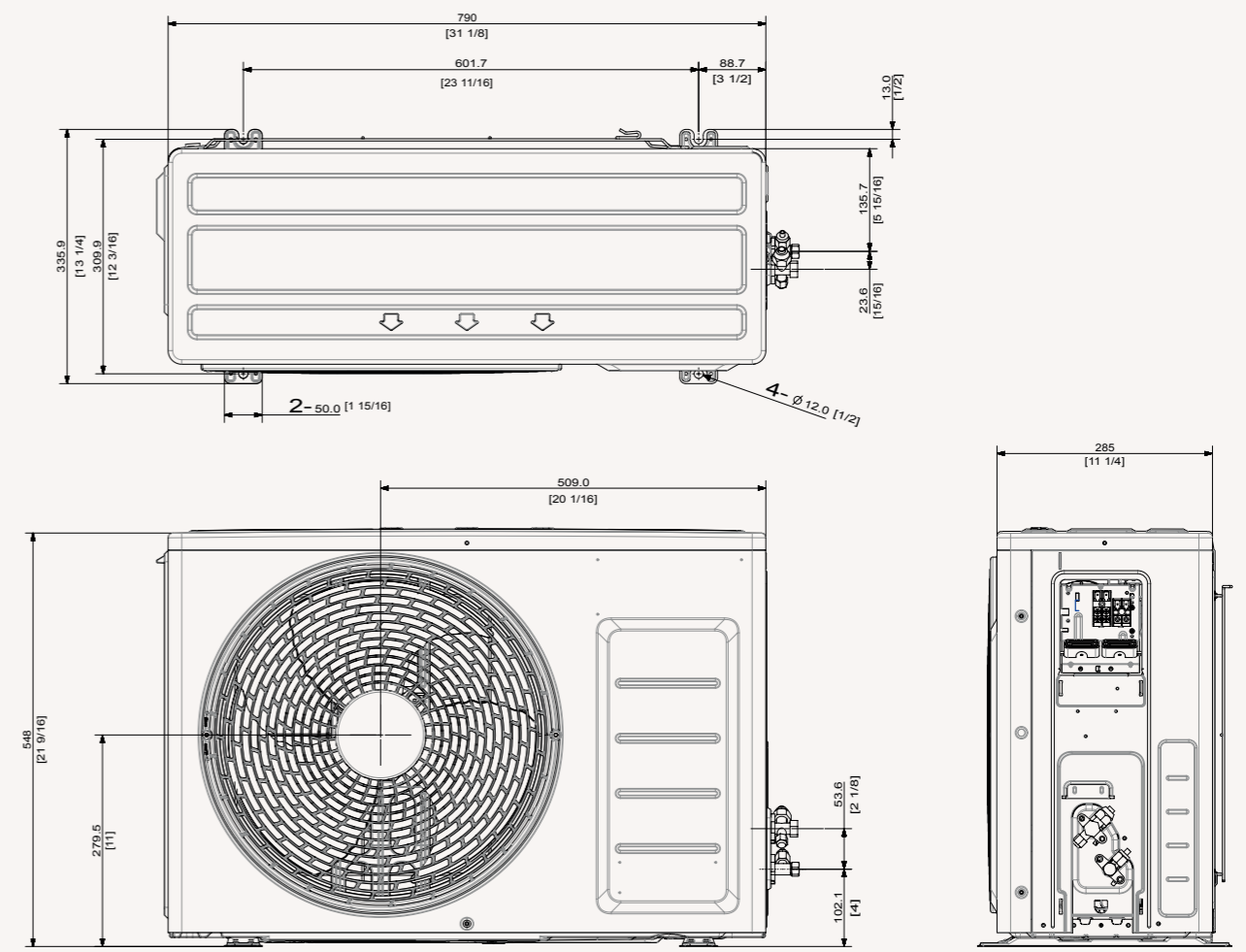

Specifications

Wind-Free™ Avant R32

- Three-step cooling: Fast Cooling mode, Dehumidification mode and Wind-Free™ Cooling mode.
- Tri-Care Filter system with Zeolite Coating.
- AI Auto Comfort.
- Wi-Fi Control with Samsung SmartThings and Bixby voice controls.
- Compressor with Digital Inverter Boost technology.
- Equipped with NASA communication protocol.
- Direct drive fan powered by a BLDC motor.
- Triple Protector Plus to protect compressor, fin and controller from power surges.



Indoor Unit			AR09TXEAAWKNEU	AR12TXEAAWKNEU	AR18TXEAAWKNEU	AR24TXEAAWKNEU
Outdoor Unit			AR09TXEAAWKXEU	AR12TXEAAWKXEU	AR18TXEAAWKXEU	AR24TXEAAWKXEU
Capacity						
Capacity	Cooling (Nominal)	kW	2.5	3.5	5.0	6.5
	Cooling (Min-Max)	kW	1.0-3.4	1.0-4.0	1.6-6.7	1.4-7.6
	Heating @ +7 °C	kW	3.2	4.0	6.0	7.4
	Heating (Min-Max)	kW	0.72-5.00	0.74-5.50	1.30-8.00	1.20-9.70
	Heating @ -5 °C	kW	3.62	3.59	5.07	6.04
	Heating @ -10 °C	kW	3.37	3.33	4.70	5.65
Heating @ -15 °C	kW	3.12	3.07	4.63	5.60	
Performance						
Energy Efficiency Cooling	SEER ¹	W/W	79/ A++	7.3/ A++	6.8/ A++	6.4/ A++
	Power Consumption	kWh/a	111	168	257	355
	Pdesignc	kW	2.5	3.5	5.0	6.5
	EER	W/W	4.39	3.76	3.60	3.33
Energy Efficiency Heating	SCOP ¹	W/W	4.6/ A++	4.6/ A++	4.1/ A+	4.0/ A+
	Power Consumption	kWh/a	670	730	1,298	1,435
	Pdesignh (average)	kW	2.2	2.4	3.8	4.1
	COP ¹	W/W	4.21	3.74	3.53	3.15
Moisture Removal	L/h		1.0	1.5	2.0	2.5
Maximum Airflow (Cooling)	Indoor Unit	m ³ /min	9.5	10.5	15.7	17.6
	Outdoor Unit	m ³ /min	45.0	45.0	50.0	50.0
Sound Power	Indoor Unit (Cooling)	dB(A)	57	57	58	62
	Outdoor Unit (Cooling)	dB(A)	59	62	65	68
Sound Pressure	Indoor Unit High/Silent Mode	dB(A)	38/16	40/16	41/25	45/26
	Outdoor Unit High	dB(A)	45	46	51	54
Operating Temperature Range	Cooling	°C	-10-46	-10-46	-10-46	-10-46
	Heating	°C	-15-24	-15-24	-15-24	-15-24
Electrical Data						
Power Source	Φ, V, Hz		1Φ, 220-240 V, 50 Hz	1Φ, 220-240 V, 50 Hz	1Φ, 220-240 V, 50 Hz	1Φ, 220-240 V, 50 Hz
Compressor Type	Outdoor Unit	Type	BLDC Rotary	BLDC Rotary	BLDC Rotary	BLDC Rotary
Power Consumption	Cooling	W	570	930	1,390	1,950
	Heating	W	760	1,070	1,700	2,350
Operating Current	Cooling	A	3.4	4.5	6.4	8.8
	Heating	A	3.7	5.1	7.8	10.5
Dimensions						
Net Dimensions (W x H x D)	Indoor Unit	mm	889 x 299 x 215	889 x 299 x 215	1,055 x 299 x 215	1,055 x 299 x 215
	Outdoor Unit	mm	790 x 548 x 285	790 x 548 x 285	880 x 638 x 310	880 x 638 x 310
Net Weight	Indoor Unit	kg	9.9	9.9	12.2	12.5
	Outdoor Unit	kg	29.9	29.9	39.7	43.7
Refrigerant						
Refrigerant	Type		R32 (contains fluorinated greenhouse gases. GWP = 675)			
Charging (for 5 m)	kg		0.94	0.94	1.30	1.30
	tCO ₂ e		0.63	0.63	0.88	0.88
	g/m		15	15	15	15
Piping Connections	Liquid Pipe	ø, mm (inch)	6.35 (1/4)	6.35 (1/4)	6.35 (1/4)	6.35 (1/4)
	Gas Pipe	ø, mm (inch)	9.52 (3/8)	9.52 (3/8)	9.52 (3/8)	9.20 (3/8)
Piping Length	Min/Max (ODU to IDU)	m	3/15	3/15	3/30	3/30
Piping Height	Max	m	8	8	15	15
Piping Connections	Drain Pipe	ø, mm	ø16.3, 550 mm	ø16.3, 550 mm	ø16.3, 550 mm	ø16.3, 550 mm



Indoor Unit			AR09TXEAAWKNEU	AR12TXEAAWKNEU	AR18TXEAAWKNEU	AR24TXEAAWKNEU
Outdoor Unit			AR09TXEAAWKXEU	AR12TXEAAWKXEU	AR18TXEAAWKXEU	AR24TXEAAWKXEU
Functions						
Airflow	Wind-Free™ Cooling		●	●	●	●
	Air Direction Control (Up/Down)		Auto	Auto	Auto	Auto
	Air Direction Control (Left/Right)		Auto	Auto	Auto	Auto
	Auto Fan Speed		●	●	●	●
Air Purification	Tri-Care Filter		●	●	●	●
	Easy Filter Plus		●	●	●	●
	Auto Clean (Self-Cleaning)		●	●	●	●
Operating Mode	AI Auto Comfort with Wi-Fi & MDS (direct/indirect)		●	●	●	●
	AI Auto Comfort with Wi-Fi		●	●	●	●
	Auto Mode (without Wi-Fi)		●	●	●	●
	Fast Cooling		●	●	●	●
	Good Sleep		●	●	●	●
	Eco		●	●	●	●
	Dehumidification		●	●	●	●
	Fan		●	●	●	●
	Quiet		●	●	●	●
	Other Functions	Samsung SmartThings		●	●	●
MDS (Motion Detect Sensor)		●	●	●	●	
Indoor Temperature Display		●	●	●	●	
Display On/Off	88 Display		●	●	●	
Beep On/Off			●	●	●	
Auto Changeover			●	●	●	
Auto Restart			●	●	●	

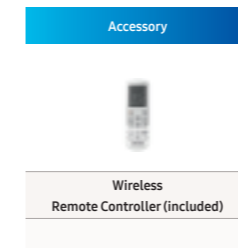

¹Energy labels as shown are according to EU No 626/2011 (LOT10) label classification 2019, on a scale from D to A+++.

Dimensional drawings

Wind-Free™ Avant - Indoor

AR09/12TXEAAWKNEU

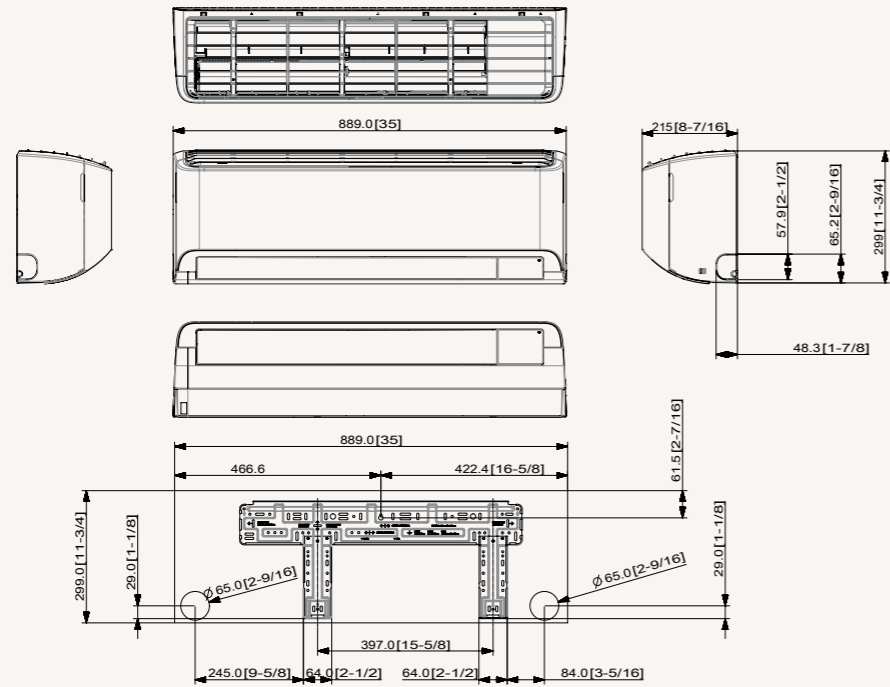

v

Wind-Free™ Avant - Outdoor

AR18/24TXEAAWKXEU

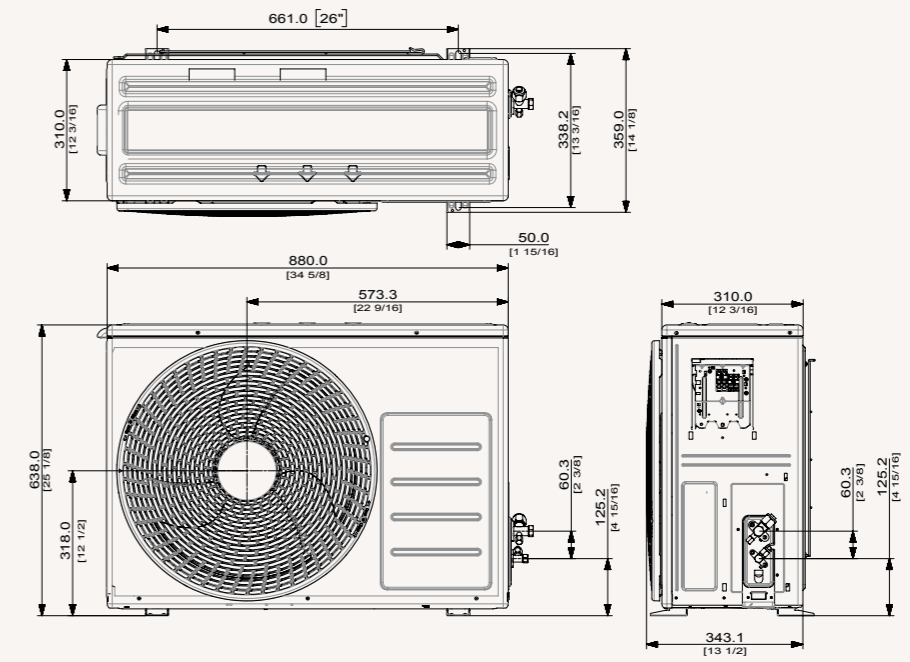

AR18/24TXEAAWKNEU

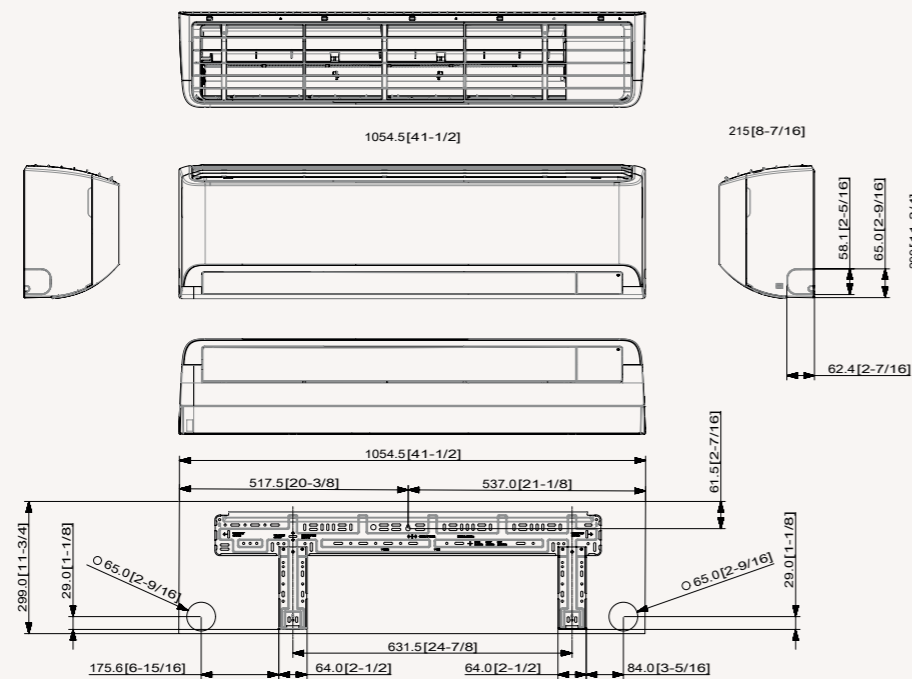

AR18/24TXEAAWKXEU

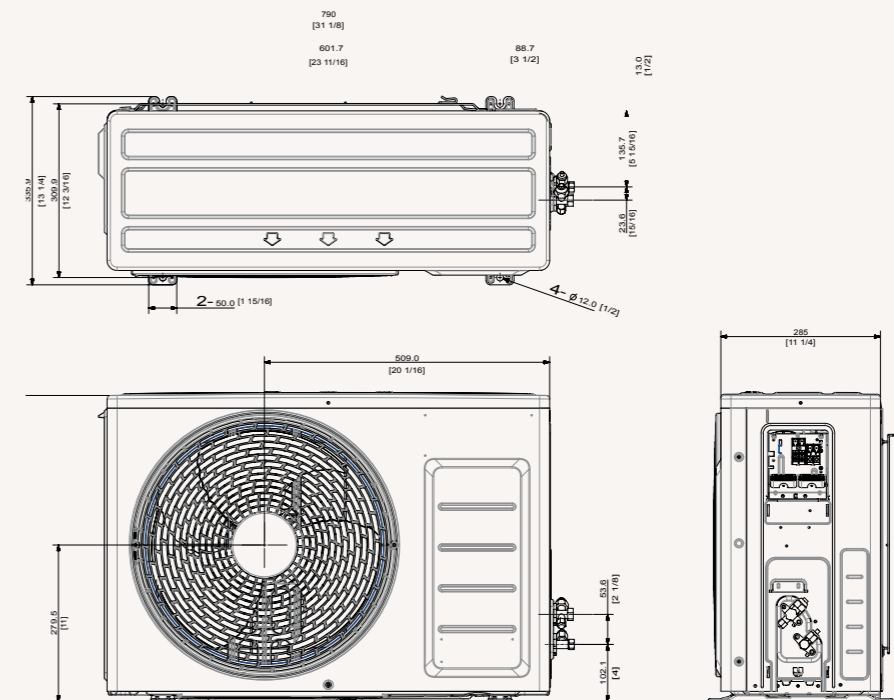

Specifications

Wind-Free™ Comfort R32

- Three-step cooling: Fast Cooling mode, Dehumidification mode and Wind-Free™ Cooling mode.
- AI Auto Comfort.
- Wi-Fi Control with Samsung SmartThings and Bixby voice controls.
- Compressor with Digital Inverter Boost technology.
- Equipped with NASA communication protocol.
- Direct drive fan powered by a BLDC motor.
- Triple Protector Plus to protect compressor, fan and controller from power surges.



Indoor Unit			AR09TXFCWKNEU	AR12TXFCWKNEU	AR18TXFCWKNEU	AR24TXFCWKNEU
Outdoor Unit			AR09TXFCWKXEU	AR12TXFCWKXEU	AR18TXFCWKXEU	AR24TXFCWKXEU
Capacity						
Capacity	Cooling (Nominal)	kW	2.5	3.5	5.0	6.5
	Cooling (Min-Max)	kW	0.9-3.4	0.9-4.0	1.6-6.7	1.4-7.6
	Heating @ +7 °C	kW	3.2	3.5	6.0	7.4
	Heating (Min-Max)	kW	0.9-4.5	0.9-5.0	1.3-8.0	1.2-9.4
	Heating @ -5 °C	kW	2.74	3.09	4.84	6.00
	Heating @ -10 °C	kW	2.48	2.87	4.57	5.55
Heating @ -15 °C	kW	2.29	2.58	4.58	5.66	
Performance						
Energy Efficiency Cooling	SEER ¹	W/W	6.7/ A++	6.5/ A++	6.8/ A++	6.4/ A++
	Power Consumption	kWh/a	131	188	257	355
	Pdesignc	kW	2.5	3.5	5.0	6.5
	EER	W/W	3.57	2.87	3.60	3.33
Energy Efficiency Heating	SCOP ¹	W/W	4.0/ A+	4.0/ A+	3.8/ A	3.8/ A
	Power Consumption	kWh/a	735	770	1,400	1,511
	Pdesignh (average)	kW	2.1	2.2	3.8	4.1
	COP ¹	W/W	3.81	3.72	3.51	3.15
Moisture Removal	L/h		1.0	1.5	2.0	2.5
Maximum Airflow (Cooling)	Indoor Unit	m ³ /min	10.3	10.7	16.6	17.3
	Outdoor Unit	m ³ /min	28.0	28.0	50.0	50.0
Sound Power	Indoor Unit (Cooling)	dB(A)	54	56	58	62
	Outdoor Unit (Cooling)	dB(A)	63	64	65	68
Sound Pressure	Indoor Unit High/Silent Mode	dB(A)	37/19	38/19	41/25	45/26
	Outdoor Unit High	dB(A)	46	47	51	54
Operating Temperature Range	Cooling	°C	-10-46	-10-46	-10-46	-10-46
	Heating	°C	-15-24	-15-24	-15-24	-15-24
Electrical Data						
Power Source	Φ, V, Hz		1Φ, 220-240 V, 50 Hz	1Φ, 220-240 V, 50 Hz	1Φ, 220-240 V, 50 Hz	1Φ, 220-240 V, 50 Hz
Compressor Type	Outdoor Unit	Type	BLDC Rotary	BLDC Rotary	BLDC Rotary	BLDC Rotary
Power Consumption	Cooling	W	700	1,200	1,390	1,950
	Heating	W	840	940	1,710	2,350
Operating Current	Cooling	A	3.4	4.5	6.4	8.8
	Heating	A	3.7	5.1	7.8	10.5
Dimensions						
Net Dimensions (W x H x D)	Indoor Unit	mm	820 x 299 x 215	820 x 299 x 215	1,055 x 299 x 215	1,055 x 299 x 215
	Outdoor Unit	mm	660 x 475 x 242	660 x 475 x 242	880 x 638 x 310	880 x 638 x 310
Net Weight	Indoor Unit	kg	8.9	8.9	11.5	11.6
	Outdoor Unit	kg	23.0	23.0	39.7	43.2
Refrigerant						
Refrigerant	Type		R32 (contains fluorinated greenhouse gases. GWP = 675)			
Charging (for 5 m)	kg		0.70	0.70	1.30	1.15
	tCO ₂ e		0.47	0.47	0.88	0.78
	g/m		15	15	15	15
Piping Connections	Liquid Pipe	ø, mm (inch)	6.35 (1/4)	6.35 (1/4)	6.35 (1/4)	6.35 (1/4)
	Gas Pipe	ø, mm (inch)	9.52 (3/8)	9.52 (3/8)	12.70 (1/2)	15.88 (5/8)
Piping Length	Min/Max (ODU to IDU)	m	3/15	3/15	3/30	3/30
Piping Height	Max	m	8	8	15	15
Piping Connections	Drain Pipe	ø, mm	ø16.3, 550 mm	ø16.3, 550 mm	ø16.3, 550 mm	ø16.3, 550 mm



Indoor Unit			AR09TXFCWKNEU	AR12TXFCWKNEU	AR18TXFCWKNEU	AR24TXFCWKNEU
Outdoor Unit			AR09TXFCWKXEU	AR12TXFCWKXEU	AR18TXFCWKXEU	AR24TXFCWKXEU
Functions						
Airflow	Wind-Free™ Cooling		●	●	●	●
	Air Direction Control (Up/Down)		Auto	Auto	Auto	Auto
	Air Direction Control (Left/Right)		Auto	Auto	Auto	Auto
	Auto Fan Speed		●	●	●	●
Air Purification	Tri-Care Filter					
	Easy Filter Plus		●	●	●	●
	Auto Clean (Self-Cleaning)		●	●	●	●
Operating Mode	AI Auto Comfort with Wi-Fi & MDS (direct/indirect)					
	AI Auto Comfort with Wi-Fi		●	●	●	●
	Auto Mode (without Wi-Fi)					
	Fast Cooling		●	●	●	●
	Good Sleep		●	●	●	●
	Eco		●	●	●	●
	Dehumidification		●	●	●	●
	Fan		●	●	●	●
	Quiet		●	●	●	●
	Other Functions	Samsung SmartThings		●	●	●
MDS (Motion Detect Sensor)						
Indoor Temperature Display		●	●	●	●	
Display On/Off	88 Display		●	●	●	
Beep On/Off		●	●	●	●	
Auto Changeover		●	●	●	●	
Auto Restart		●	●	●	●	

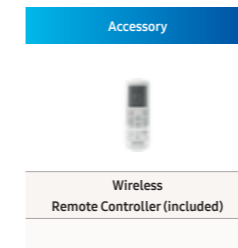

¹Energy labels as shown are according to EU No 626/2011 (LOT10) label classification 2019, on a scale from D to A+++.

Dimensional drawings

Wind-Free™ Comfort - Indoor

AR09/12TXFCWKNEU

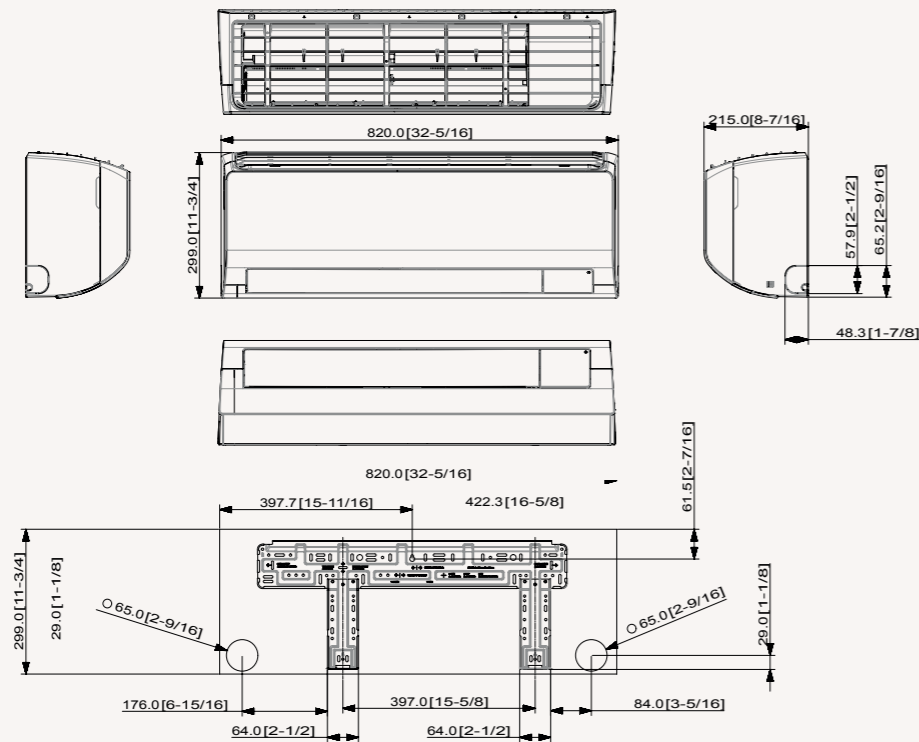

AR18/24TXFCWKNEU

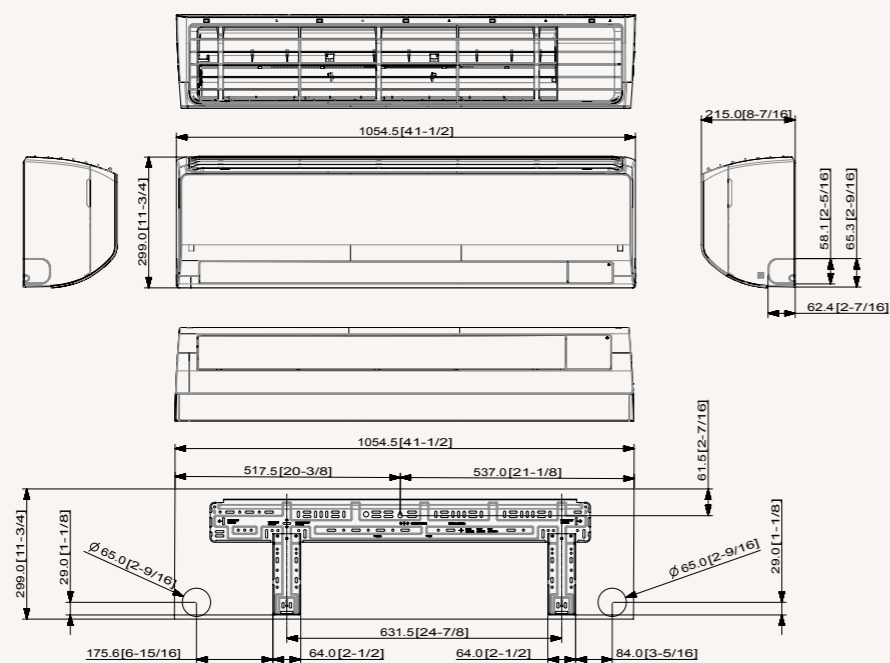

Wind-Free™ Comfort - Outdoor

AR09/12TXFCWKXEU

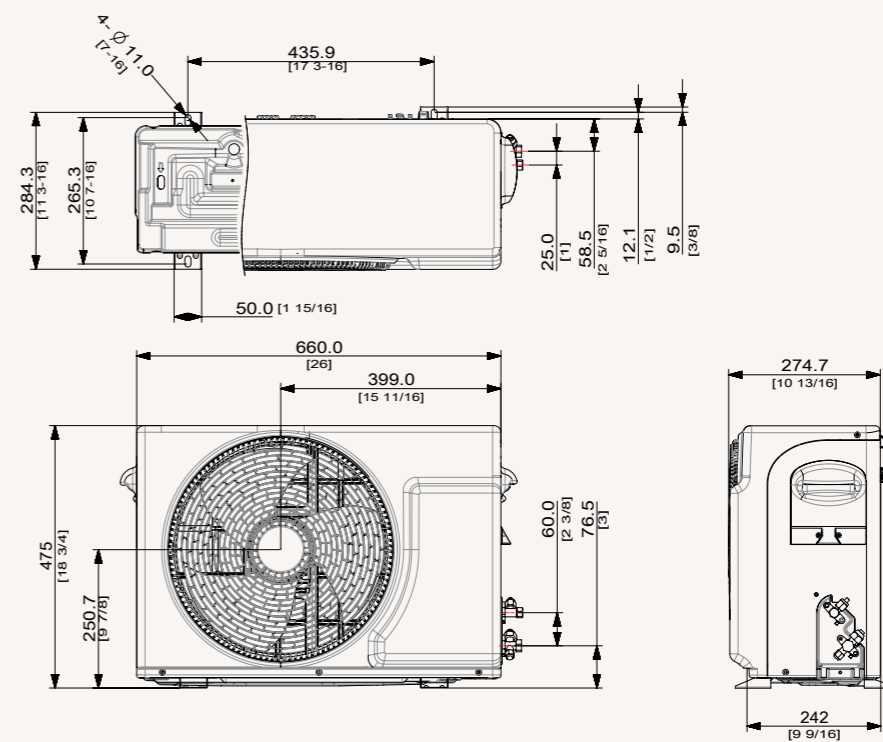

AR18/24TXFCWKXEU

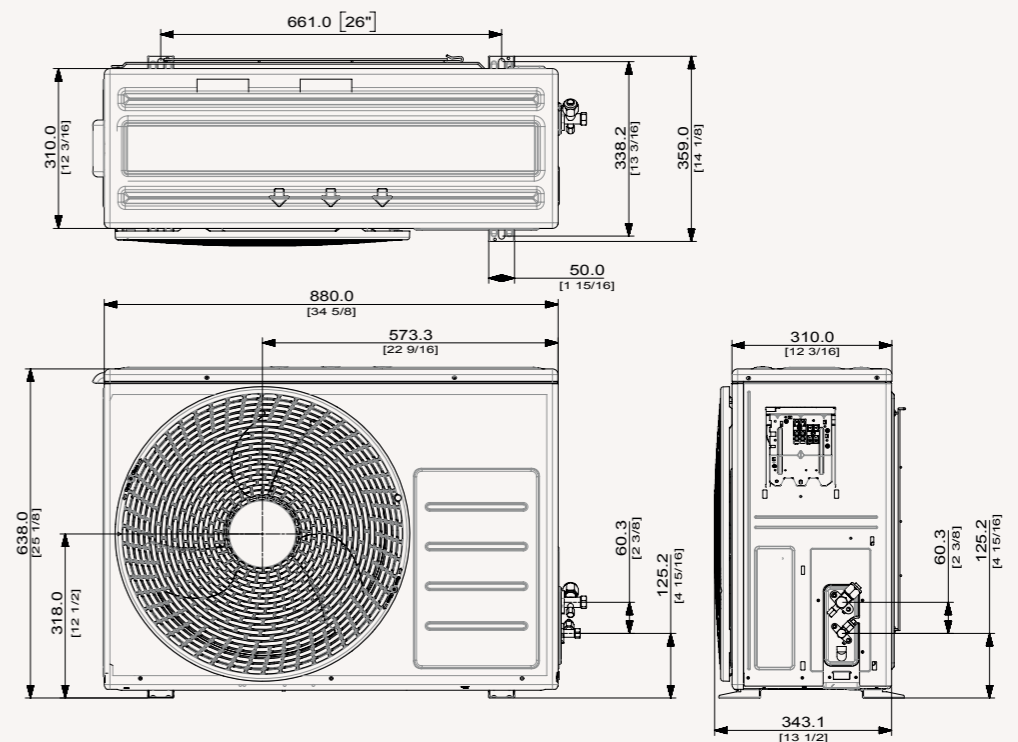

Specifications

Cebu **R32**

- AI Auto Comfort.
- Wi-Fi Control with Samsung SmartThings and Bixby voice controls.
- Compressor with Digital Inverter Boost technology.
- Equipped with NASA communication protocol.
- Direct drive fan powered by a BLDC motor.
- Triple Protector Plus to protect compressor, fan and controller from power surges.



Indoor Unit		AR09TFYAWKNEU	AR12TFYAWKNEU	AR18TFYAWKNEU	AR24TFYAWKNEU	
Outdoor Unit		AR09TFYAWKXEU	AR12TFYAWKXEU	AR18TFYAWKXEU	AR24TFYAWKXEU	
Capacity						
Capacity	Cooling (Nominal)	kW	2.5	3.5	5.0	6.5
	Cooling (Min-Max)	kW	0.9-3.4	0.9-4.0	1.6-6.7	1.4-7.6
	Heating @ +7 °C	kW	3.2	3.5	6.0	7.4
	Heating (Min-Max)	kW	0.9-4.5	0.9-5.0	1.3-8.0	1.2-9.4
	Heating @ -5 °C	kW	2.74	3.09	4.84	6.00
	Heating @ -10 °C	kW	2.48	2.87	4.57	5.55
	Heating @ -15 °C	kW	2.29	2.58	4.58	5.66
Performance						
Energy Efficiency Cooling	SEER ¹	W/W	6.7/ A++	6.5/ A++	6.8/ A++	6.4/ A++
	Power Consumption	kWh/a	131	188	257	355
	Pdesignc	kW	2.5	3.5	5.0	6.5
	EER	W/W	3.57	2.87	3.60	3.33
	Energy Efficiency Heating	SCOP ¹	W/W	4.0/ A+	4.0/ A+	3.8/ A
	Power Consumption	kWh/a	735	770	1,400	1,511
	Pdesignh (average)	kW	2.1	2.2	3.8	4.1
	COP ¹	W/W	3.81	3.72	3.53	3.15
Moisture Removal	L/h		1.0	1.5	2.0	2.5
Maximum Airflow (Cooling)	Indoor Unit	m ³ /min	10.5	10.9	16.5	17.2
	Outdoor Unit	m ³ /min	28.0	28.0	50.0	50.0
Sound Power	Indoor Unit (Cooling)	dB(A)	54	56	58	62
	Outdoor Unit (Cooling)	dB(A)	63	64	65	68
Sound Pressure	Indoor Unit High/Silent Mode	dB(A)	37/19	38/19	41/25	45/26
	Outdoor Unit High	dB(A)	46	47	51	54
Operating Temperature Range	Cooling	°C	-10-46	-10-46	-10-46	-10-46
	Heating	°C	-15-24	-15-24	-15-24	-15-24
Electrical Data						
Power Source	Φ, V, Hz		1Φ, 220-240 V, 50 Hz	1Φ, 220-240 V, 50 Hz	1Φ, 220-240 V, 50 Hz	1Φ, 220-240 V, 50 Hz
Compressor Type	Outdoor Unit	Type	BLDC Rotary	BLDC Rotary	BLDC Rotary	BLDC Rotary
Power Consumption	Cooling	W	700	1,220	1,390	1,950
	Heating	W	840	940	1,700	2,350
Operating Current	Cooling	A	3.6	5.6	6.4	8.8
	Heating	A	4.0	4.5	7.8	10.5
Dimensions						
Net Dimensions (W x H x D)	Indoor Unit	mm	820 x 299 x 215	820 x 299 x 215	1,055 x 299 x 215	1,055 x 299 x 215
	Outdoor Unit	mm	660 x 475 x 242	660 x 475 x 242	880 x 638 x 310	880 x 638 x 310
Net Weight	Indoor Unit	kg	9.1	9.1	11.5	11.6
	Outdoor Unit	kg	22.6	22.6	39.7	43.2
Refrigerant						
Refrigerant	Type		R32 (contains fluorinated greenhouse gases. GWP = 675)			
	Charging (for 5 m)	kg	0.70	0.70	1.30	1.30
	Charging Ton Equivalent CO ₂	tCO ₂ e	0.47	0.47	0.88	0.88
	Additional Refrigerant Charging	g/m	15	15	15	15
Piping Connections	Liquid Pipe	ø, mm (inch)	6.35 (1/4)	6.35 (1/4)	6.35 (1/4)	6.35 (1/4)
	Gas Pipe	ø, mm (inch)	9.52 (3/8)	9.52 (3/8)	9.52 (3/8)	9.52 (3/8)
Piping Length	Min/Max (ODU to IDU)	m	3/15	3/15	3/15	3/15
Piping Height	Max	m	8	8	8	8
Piping Connections	Drain Pipe	ø, mm	ø16.3, 550 mm	ø16.3, 550 mm	ø16.3, 550 mm	ø16.3, 550 mm

Indoor Unit		AR09TFYAWKNEU	AR12TFYAWKNEU	AR18TFYAWKNEU	AR24TFYAWKNEU
Outdoor Unit		AR09TFYAWKXEU	AR12TFYAWKXEU	AR18TFYAWKXEU	AR24TFYAWKXEU
Functions					
Airflow	Wind-Free™ Cooling				
	Air Direction Control (Up/Down)	Auto	Auto	Auto	Auto
	Air Direction Control (Left/Right)	Manual	Manual	Manual	Manual
	Auto Fan Speed	•	•	•	•
Air Purification	Tri-Care Filter				
	Easy Filter Plus	•	•	•	•
	Auto Clean (Self-Cleaning)	•	•	•	•
Operating Mode	AI Auto Comfort with Wi-Fi & MDS (direct/indirect)				
	AI Auto Comfort with Wi-Fi	•	•	•	•
	Auto Mode (without Wi-Fi)				
	Fast Cooling	•	•		
	Good Sleep	•	•	•	•
	Eco	•	•	•	•
	Dehumidification	•	•	•	•
	Fan	•	•	•	•
	Quiet			•	•
	Other Functions	Samsung SmartThings	•	•	•
MDS (Motion Detect Sensor)					
Indoor Temperature Display			•	•	•
Display On/Off		88 Display	•	•	•
Beep On/Off			•	•	•
Auto Changoover			•	•	•
Auto Restart			•	•	•

Accessory



Wireless Remote Controller (included)

¹Energy labels as shown are according to EU No 626/2011 (LOT10) label classification 2019, on a scale from D to A+++.

Dimensional drawings

Cebu - Indoor

AR09/12TXFYAWKNEU

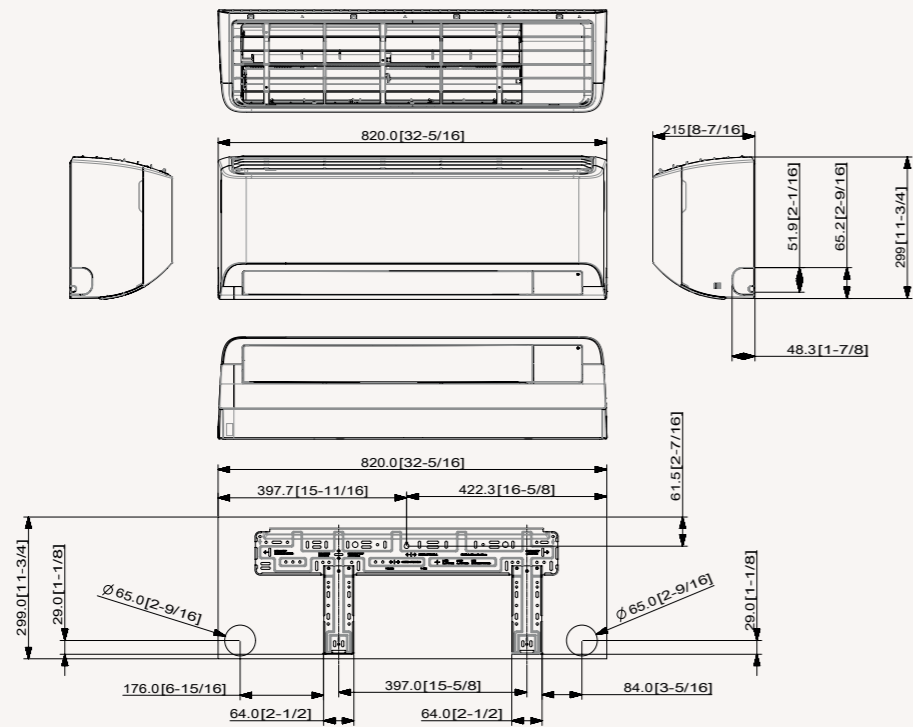

AR18/24TXFYAWKNEU

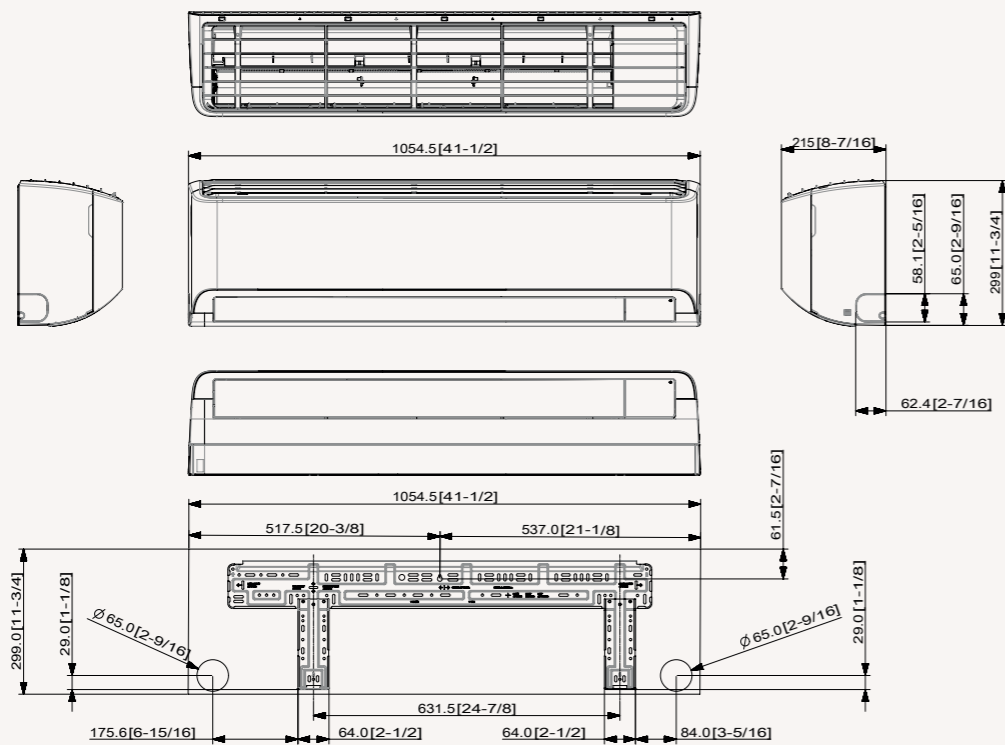

Cebu - Outdoor

AR09/12TXFYAWKXEU

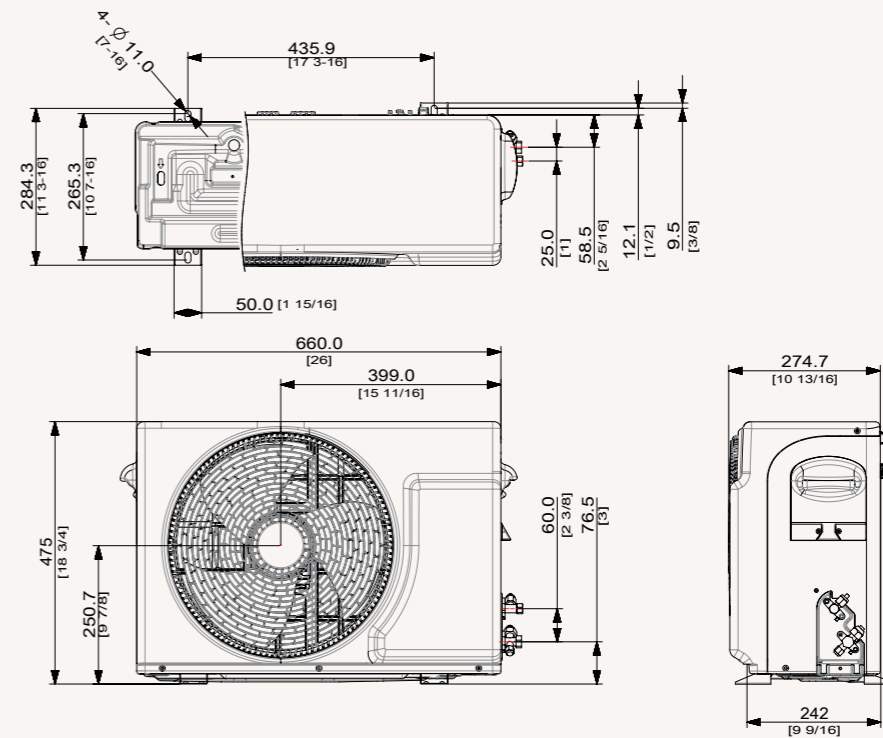

AR18/24TXFYAWKXEU

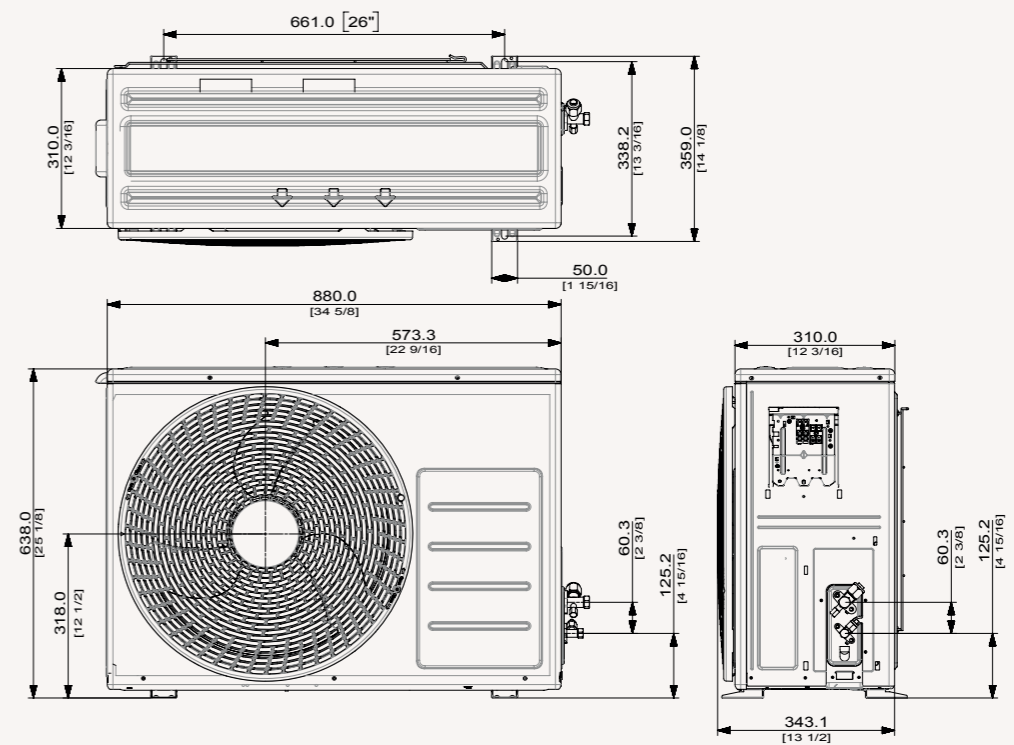

Specifications

Luzon **R32**

- Compressor with Digital Inverter Boost technology.
- Equipped with NASA communication protocol.
- Direct drive fan powered by a BLDC motor.
- Triple Protector Plus to protect compressor, fin and controller from power surges.



Indoor Unit			AR09TXHZAWKNEU	AR12TXHZAWKNEU	AR18TXHZAWKNEU	AR24TXHZAWKNEU
Outdoor Unit			AR09TXHZAWKXEU	AR12TXHZAWKXEU	AR18TXHZAWKXEU	AR24TXHZAWKXEU
Capacity						
Capacity	Cooling (Nominal)	kW	2.5	3.5	5.0	6.5
	Cooling (Min-Max)	kW	0.9-3.4	0.9-4.0	1.6-6.7	1.4-7.6
	Heating @ +7 °C	kW	3.2	3.5	6.0	7.4
	Heating (Min-Max)	kW	0.9-4.5	0.9-5.0	1.3-8.0	1.2-9.4
	Heating @ -5 °C	kW	2.74	3.09	4.84	6.00
	Heating @ -10 °C	kW	2.48	2.87	4.57	5.55
	Heating @ -15 °C	kW	2.29	2.58	4.58	5.66
Performance						
Energy Efficiency Cooling	SEER ¹	W/W	6.7/ A++	6.5/ A++	6.8/ A++	6.4/ A++
	Power Consumption	kWh/a	131	188	257	355
	Pdesignc	kW	2.5	3.5	5.0	6.5
	EER	W/W	3.57	2.87	3.60	3.33
Energy Efficiency Heating	SCOP ¹	W/W	4.0/ A+	4.0/ A+	3.8/ A	4.0/ A
	Power Consumption	kWh/a	735	770	1,400	1,511
	Pdesignh (average)	kW	2.1	2.2	3.8	4.1
	COP ¹	W/W	3.81	3.72	3.51	3.15
Moisture Removal	L/h		1.0	1.5	2.0	2.5
Maximum Airflow (Cooling)	Indoor Unit	m ³ /min	10.5	10.9	16.5	17.2
	Outdoor Unit	m ³ /min	28.0	28.0	50.0	50.0
Sound Power	Indoor Unit (Cooling)	dB(A)	54	56	58	62
	Outdoor Unit (Cooling)	dB(A)	63	64	65	68
Sound Pressure	Indoor Unit High/Silent Mode	dB(A)	37/19	38/19	41/25	45/26
	Outdoor Unit High	dB(A)	46	47	51	54
Operating Temperature Range	Cooling	°C	-10-46	-10-46	-10-46	-10-46
	Heating	°C	-15-24	-15-24	-15-24	-15-24
Electrical Data						
Power Source		Φ, V, Hz	1Φ, 220-240 V, 50 Hz	1Φ, 220-240 V, 50 Hz	1Φ, 220-240 V, 50 Hz	1Φ, 220-240 V, 50 Hz
Compressor Type	Outdoor Unit	Type	BLDC Rotary	BLDC Rotary	BLDC Rotary	BLDC Rotary
Power Consumption	Cooling	W	700	1,220	1,390	1,950
	Heating	W	840	940	1,710	2,350
Operating Current	Cooling	A	3.6	5.6	6.4	8.8
	Heating	A	4.0	4.5	7.8	10.5
Dimensions						
Net Dimensions (W x H x D)	Indoor Unit	mm	820 x 299 x 215	820 x 299 x 215	1,055 x 299 x 215	1,055 x 299 x 215
	Outdoor Unit	mm	660 x 475 x 242	660 x 475 x 242	880 x 638 x 310	880 x 638 x 310
Net Weight	Indoor Unit	kg	9.1	9.1	11.5	11.6
	Outdoor Unit	kg	22.6	22.6	39.7	43.2
Refrigerant						
Refrigerant	Type		R32 (contains fluorinated greenhouse gases. GWP = 675)			
	Charging (for 5 m)	kg	0.70	0.70	1.30	1.30
	Charging Ton Equivalent CO ₂	tCO ₂ e	0.47	0.47	0.88	0.88
	Additional Refrigerant Charging	g/m	15	15	15	15
Piping Connections	Liquid Pipe	ø, mm (inch)	6.35 (1/4)	6.35 (1/4)	6.35 (1/4)	6.35 (1/4)
	Gas Pipe	ø, mm (inch)	9.52 (3/8)	9.52 (3/8)	12.70 (1/2)	15.88 (5/8)
Piping Length	Min/Max (ODU to IDU)	m	3/15	3/15	3/30	3/30
Piping Height	Max	m	8	8	15	15
Piping Connections	Drain Pipe	ø, mm	ø16.3, 550 mm	ø16.3, 550 mm	ø16.3, 550 mm	ø16.3, 550 mm



Indoor Unit			AR09TXHZAWKNEU	AR12TXHZAWKNEU	AR18TXHZAWKNEU	AR24TXHZAWKNEU
Outdoor Unit			AR09TXHZAWKXEU	AR12TXHZAWKXEU	AR18TXHZAWKXEU	AR24TXHZAWKXEU
Functions						
Airflow	Wind-Free™ Cooling					
	Air Direction Control (Up/Down)		Auto	Auto	Auto	Auto
	Air Direction Control (Left/Right)		Manual	Manual	Manual	Manual
	Auto Fan Speed		●	●	●	●
Air Purification	Tri-Care Filter					
	Easy Filter Plus		●	●	●	●
	Auto Clean (Self-Cleaning)		●	●	●	●
Operating Mode	AI Auto Comfort with Wi-Fi & MDS (direct/indirect)					
	AI Auto Comfort with Wi-Fi					
	Auto Mode (without Wi-Fi)		●	●	●	●
	Fast Cooling		●	●	●	●
	Good Sleep		●	●	●	●
	Eco		●	●	●	●
	Dehumidification		●	●	●	●
	Fan		●	●	●	●
	Quiet		●	●	●	●
Other Functions	Samsung SmartThings					
	MDS (Motion Detect Sensor)					
	Indoor Temperature Display		●	●	●	●
	Display On/Off	88 Display	●	●	●	●
	Beep On/Off		●	●	●	●
	Auto Changeover		●	●	●	●
Auto Restart		●	●	●	●	

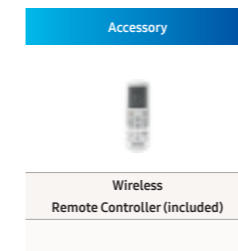

¹Energy labels as shown are according to EU No 626/2011 (LOT10) label classification 2019, on a scale from D to A+++.

Dimensional drawings

Luzon - Indoor

AR09/12TXHZAWKNEU

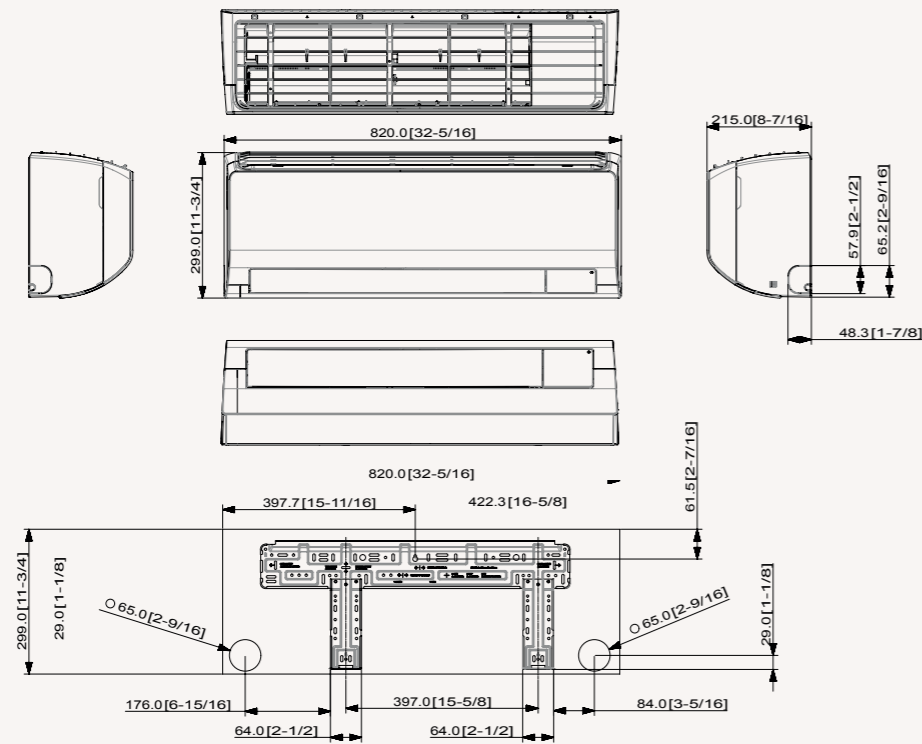

AR18/24TXHZAWKNEU

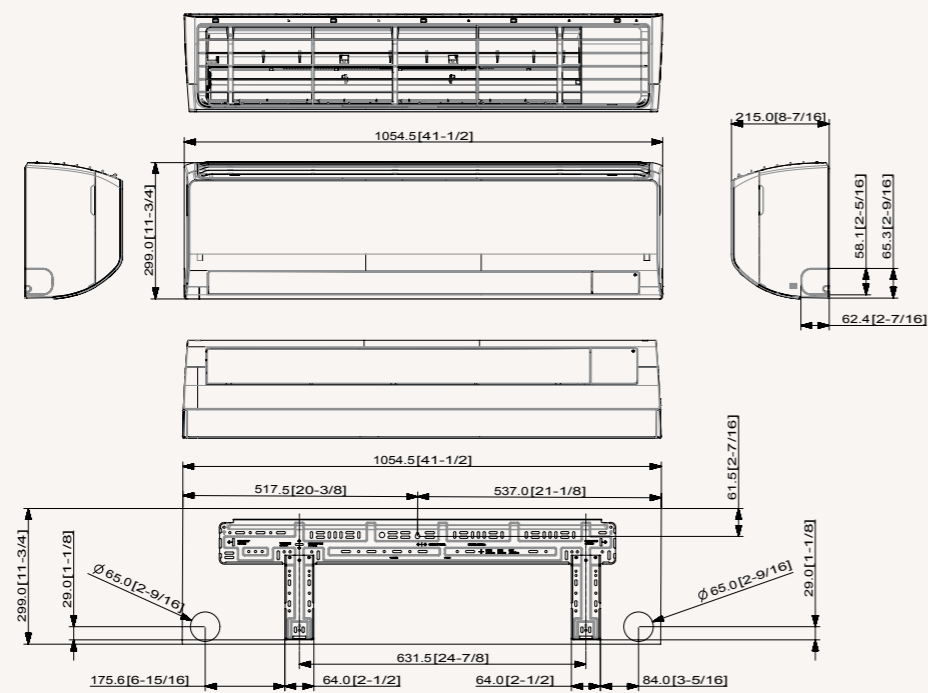

Luzon - Outdoor

AR09TXHZAWKXEU

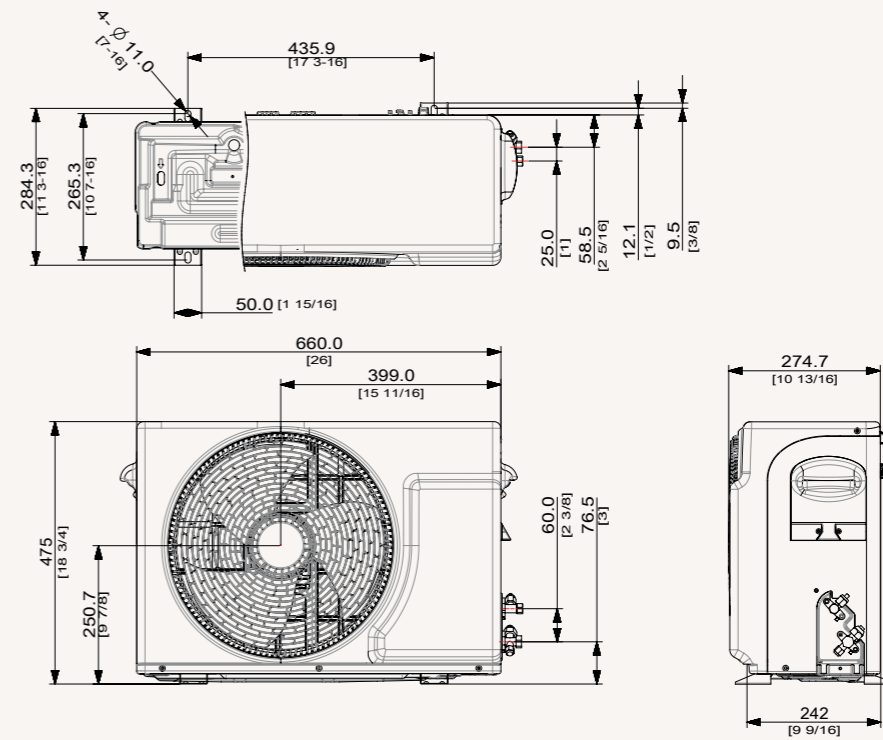

AR18/24TXHZAWKXEU

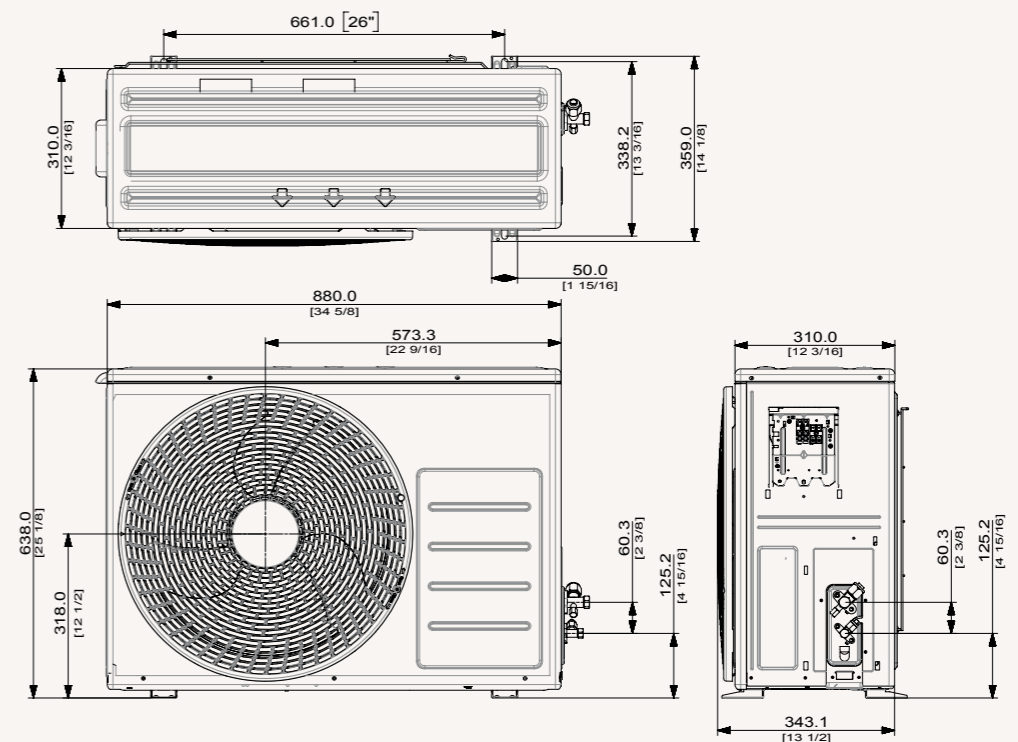

Specifications

AR35 and AR30 R32

- Digital Inverter Compressor.
- HD Filter system.
- 2-Way Auto Swing function to automatically control airflow direction.
- Fin Protector to protect condenser and optimise Heat Exchanger performance.



		AR35				AR30		
Indoor Unit		AR09TXHQASINEU	AR12TXHQASINEU	AR18TXHQASINEU	AR24TXHQASINEU	AR09TXHQBWKNEU	AR12TXHQBWKNEU	
Outdoor Unit		AR09TXHQASIXEU	AR12TXHQASIXEU	AR18TXHQASIXEU	AR24TXHQASIXEU	AR09TXHQBWKXEU	AR12TXHQBWKXEU	
Capacity								
Capacity	Cooling (Nominal)	kW	2.6	3.5	5.3	7.0	2.6	3.5
	Cooling (Min-Max)	kW	0.9-3.4	1.1-4.2	1.8-6.1	2.1-8.0	0.9-3.4	1.1-4.2
	Heating @ +7 °C	kW	2.9	3.8	5.3	7.3	2.9	3.8
	Heating (Min-Max)	kW	0.8-3.4	1.1-4.2	1.4-6.7	1.6-8.8	0.8-3.4	1.1-4.2
	Heating @ -5 °C	kW	TBA	TBA	TBA	TBA	TBA	TBA
	Heating @ -10 °C	kW	TBA	TBA	TBA	TBA	TBA	TBA
	Heating @ -15 °C	kW	TBA	TBA	TBA	TBA	TBA	TBA
Performance								
Energy Efficiency Cooling	SEER ¹	W/W	6.3/ A++	6.1/ A++	7.1/ A++	6.1/ A++	6.3/ A++	6.1/ A++
	Power Consumption	kWh/a	156	211	256	412	156	211
	Pdesignc	kW	2.8	3.6	5.2	7.0	2.8	3.6
	EER	W/W	3.43	2.90	3.43	2.87	3.43	2.90
Energy Efficiency Heating	SCOP ¹	W/W	4.0/ A+	3.9/ A	4.0/ A+	3.9/ A	4.0/ A+	3.9/ A
	Power Consumption	kWh/a	910	969	1,435	1,723	910	969
	Pdesignh (average)	kW	2.6	2.7	4.1	4.8	2.6	2.7
	COP ¹	W/W	3.91	3.50	3.56	2.71	3.91	3.50
Moisture Removal	l/h	1.0	1.2	1.8	2.6	1.0	1.2	
Maximum Airflow (Cooling)	Indoor Unit	m ³ /min	7.77	9.00	14.00	16.33	7.77	9.00
	Outdoor Unit	m ³ /min	TBA	TBA	TBA	TBA	TBA	TBA
Sound Power	Indoor Unit (Cooling)	dB(A)	55	55	55	59	55	55
	Outdoor Unit (Cooling)	dB(A)	62	65	63	68	62	65
Sound Pressure	Indoor Unit High/Silent Mode	dB(A)	36/20	37/22	42/25	43/28	36/20	37/22
	Outdoor Unit High	dB(A)	49	50	51	56	49	50
Operating Temperature Range	Cooling	°C	-10-46	-10-46	-10-46	-10-46	-10-46	-10-46
	Heating	°C	-15-24	-15-24	-15-24	-15-24	-15-24	-15-24
Electrical Data								
Power Source	Φ, V, Hz	1Φ, 220-240 V, 50 Hz	1Φ, 220-240 V, 50 Hz	1Φ, 220-240 V, 50 Hz	1Φ, 220-240 V, 50 Hz	1Φ, 220-240 V, 50 Hz	1Φ, 220-240 V, 50 Hz	
Compressor Type	Outdoor Unit	Type	Digital Inverter	Digital Inverter	Digital Inverter	Digital Inverter	Digital Inverter	
Power Consumption	Cooling	W	3.3	5.3	6.9	10.4	3.3	5.3
	Heating	W	3.2	4.7	6.4	11.7	3.2	4.7
Operating Current	Cooling	A	770.0	1,213.0	1,539.0	2,450.0	770.0	1,213.0
	Heating	A	750.0	1,088.0	1,480.0	2,700.0	750.0	1,088.0
Dimensions								
Net Dimensions (W x H x D)	Indoor Unit	mm	805 x 285 x 194	805 x 285 x 194	957 x 302 x 213	1,040 x 327 x 220	805 x 285 x 194	805 x 285 x 194
	Outdoor Unit	mm	720 x 495 x 270	720 x 495 x 270	800 x 554 x 333	845 x 702 x 363	720 x 495 x 270	720 x 495 x 270
Net Weight	Indoor Unit	kg	8.1	8.1	10.5	12.5	8.1	8.1
	Outdoor Unit	kg	23.2	23.2	34.0	52.0	23.2	23.2
Refrigerant								
Refrigerant	Type	R32 (contains fluorinated greenhouse gases. GWP = 675)						
Charging (for 5 m)	kg	0.55	0.55	1.00	1.60	0.55	0.55	
	tCO ₂ e	0.37	0.68	0.68	1.10	0.37	0.37	
	g/m	12	12	12	12	12	12	
Piping Connections	Liquid Pipe	ø, inch	1/4	1/4	1/4	1/4	1/4	
	Gas Pipe	ø, inch	3/8	3/8	3/8	3/8	3/8	
Piping Length	Min/Max (ODU to IDU)	m	25	25	30	50	25	
Piping Height	Max	m	10	10	20	25	10	
Piping Connections	Drain Pipe	ø, mm	TBA	TBA	TBA	TBA	TBA	



		AR35				AR30		
Indoor Unit		AR09TXHQASINEU	AR12TXHQASINEU	AR18TXHQASINEU	AR24TXHQASINEU	AR09TXHQBWKNEU	AR12TXHQBWKNEU	
Outdoor Unit		AR09TXHQASIXEU	AR12TXHQASIXEU	AR18TXHQASIXEU	AR24TXHQASIXEU	AR09TXHQBWKXEU	AR12TXHQBWKXEU	
Functions								
Airflow	Air Direction Control (Up/Down)	Auto	Auto	Auto	Auto	Auto	Auto	
	Air Direction Control (Left/Right)	Manual	Manual	Manual	Manual	Manual	Manual	
	Airflow Control Step (Cool/Fan)	3/3	3/3	3/3	3/3	3/3	3/3	
	Auto Fan Speed	●	●	●	●	●	●	
Air Purification	Tri-Care Filter							
	HD Filter	●	●	●	●	●	●	
	Auto Clean (Self-Cleaning)							
Operating Mode	2-Step Cooling							
	Fast Cooling	●	●	●	●	●	●	
	Comfort							
	D'light Cool							
	Good Sleep	●	●	●	●	●	●	
	Dehumidification	●	●	●	●	●	●	
	Auto	●	●	●	●	●	●	
Other Functions	Fan	●	●	●	●	●	●	
	Quiet							
	Wi-Fi Control							
	24-Hour Timer/Real Timer	●	●	●	●	●	●	
88 Display	Indoor Temperature Display	●	●	●	●	●	●	
	Display On/Off	●	●	●	●	●	●	
	Beep On/Off	●	●	●	●	●	●	
	Auto Changeover							
	Auto Restart	●	●	●	●	●	●	

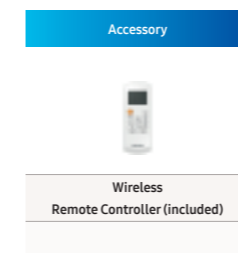

¹Energy labels as shown are according to EU No 626/2011 (LOT10) label classification 2019, on a scale from D to A+++.

Dimensional drawings

AR35 and AR30

AR09/12TXHQASINEU

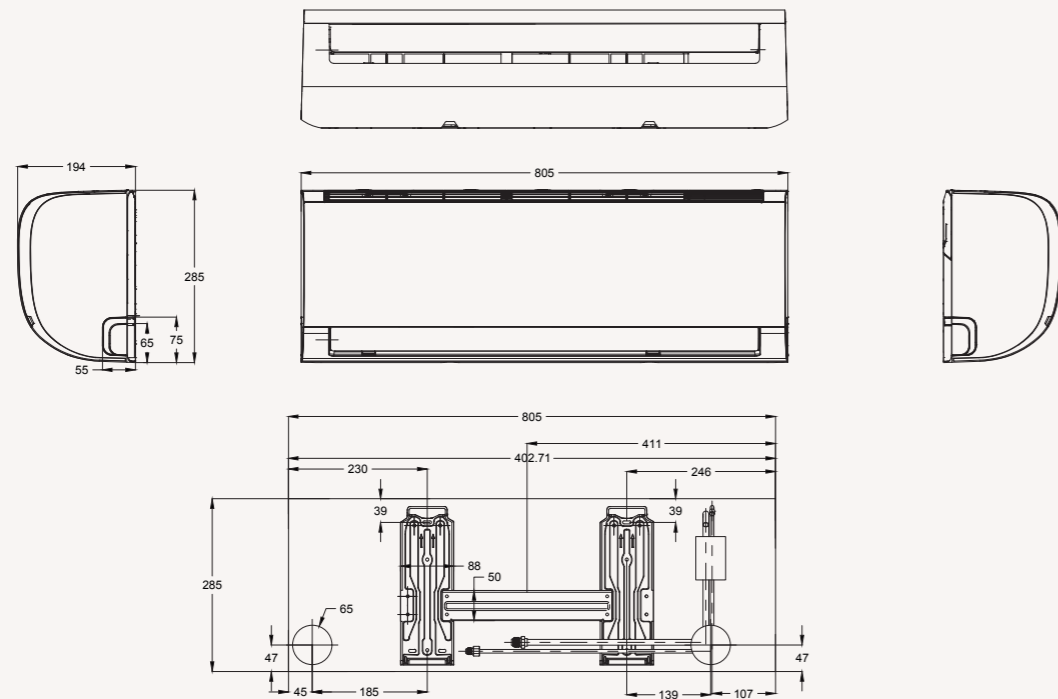

AR18TXHQASINEU

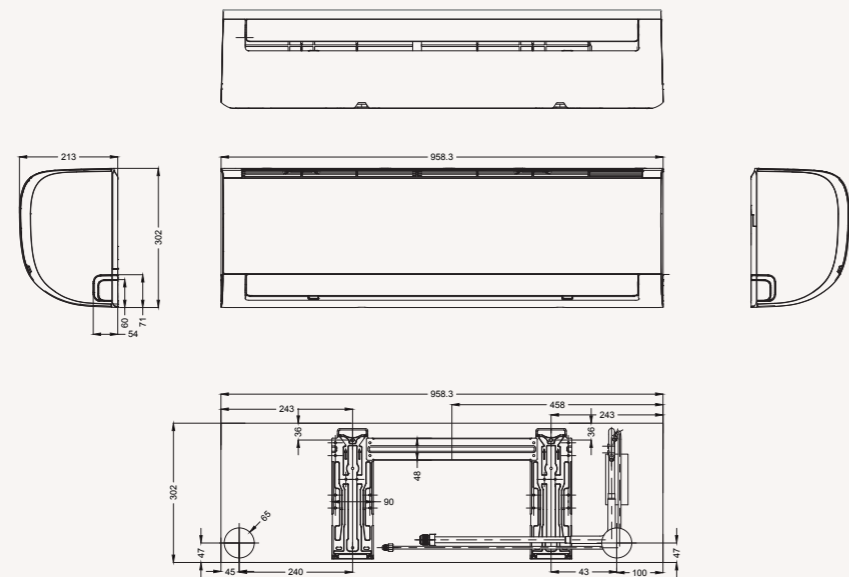

AR35 and AR30

AR24TXHQASINEU

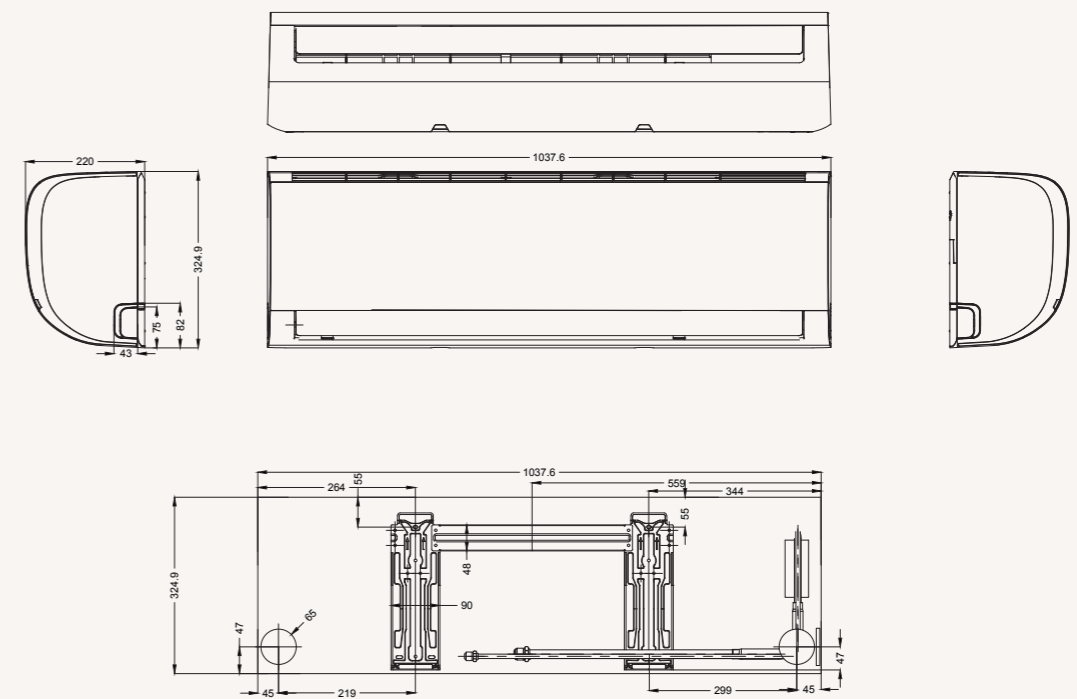

Specifications

Nordic Smart R32

- Heating down to -30 °C.
- Digital Inverter Compressor.
- 2-Step Cooling mode.
- Easy Filter Plus system.
- Wi-Fi Control with Samsung SmartThings.



Indoor Unit		AR09NXDPDWKNEE		AR12NXDPDWKNEE	
Outdoor Unit		AR09NXDPDWKXEE		AR12NXDPDWKXEE	
Capacity					
Capacity	Cooling (Nominal)	kW	2.5	3.5	
	Cooling (Min-Max)	kW	0.9-3.6	0.9-4.2	
	Heating @ +7 °C	kW	3.2	4.0	
	Heating (Min-Max)	kW	0.8-7.1	0.8-7.3	
	Heating @ -5 °C	kW	TBA	TBA	
	Heating @ -10 °C	kW	TBA	TBA	
Performance					
Energy Efficiency Cooling	SEER ¹	W/W	8.8/ A+++	8.5/ A+++	
	Power Consumption	kWh/a	99	144	
	Pdesignc	kW	TBA	TBA	
	EER	W/W	4.63	3.95	
Energy Efficiency Heating	SCOP ¹	W/W	4.9/ A++	4.8/ A++	
	Power Consumption	kWh/a	657	875	
	Pdesignh (average)	kW	TBA	TBA	
	COP ¹	W/W	4.74	4.26	
Moisture Removal		l/h	1.0	1.5	
Maximum Airflow (Cooling)	Indoor Unit	m ³ /min	10.2	10.9	
	Outdoor Unit	m ³ /min	TBA	TBA	
Sound Power	Indoor Unit (Cooling)	dB(A)	56	58	
	Outdoor Unit (Cooling)	dB(A)	59	62	
Sound Pressure	Indoor Unit Low/High	dB(A)	17/38	17/40	
	Outdoor Unit High	dB(A)	44	45	
Operating Temperature Range	Cooling	°C	-15-46	-15-46	
	Heating	°C	-30-24	-30-24	
Electrical Data					
Power Source		Φ, V, Hz	1Φ, 220-240 V, 50 Hz	1Φ, 220-240 V, 50 Hz	
Compressor Type	Outdoor Unit	Type	Rotary	Rotary	
Power Consumption	Cooling	W	540	885	
	Heating	W	675	940	
Operating Current	Cooling	A	2.9	4.1	
	Heating	A	3.4	4.4	
Dimensions					
Net Dimensions (W x H x D)	Indoor Unit	mm	896 x 261 x 261	896 x 261 x 261	
	Outdoor Unit	mm	790 x 548 x 285	790 x 548 x 285	
Net Weight	Indoor Unit	kg	11.8	11.8	
	Outdoor Unit	kg	35.0	35.0	
Refrigerant					
Refrigerant	Type		R32 (contains fluorinated greenhouse gases. GWP = 675)		
Charging (for 5 m)		kg	1.05	1.05	
	Charging Ton Equivalent CO ₂	tCO ₂ e	0.71	0.71	
	Additional Refrigerant Charging	g/m	15	15	
Piping Connections	Liquid Pipe	ø, inch	1/4	1/4	
	Gas Pipe	ø, inch	3/8	3/8	
Piping Length	Min/Max (ODU to IDU)	m	3/15	3/15	
Piping Height	Max	m	8	8	
Piping Connections	Drain Pipe	ø, mm	ID 16	ID 16	



Indoor Unit		AR09NXDPDWKNEE		AR12NXDPDWKNEE	
Outdoor Unit		AR09NXDPDWKXEE		AR12NXDPDWKXEE	
Functions					
Airflow	Wind-Free™ Cooling				
	Air Direction Control (Up/Down)		Auto	Auto	
	Air Direction Control (Left/Right)		Auto	Auto	
Air Purification	Auto Fan Speed		●	●	
	SPI Ioniser		●	●	
	PM 2.5 Filter				
	Easy Filter Plus		●	●	
	Allergy Care		●	●	
	Anti-Bacteria Coating		●	●	
Operating Mode	Auto Clean (Self-Cleaning)		●	●	
	2-Step Cooling		●	●	
	Fast Cooling		●	●	
	Comfort Cooling		●	●	
	Good Sleep		●	●	
	Dehumidification		●	●	
	Fan		●	●	
Other Functions	Quiet		●	●	
	Wi-Fi Control with Samsung SmartThings		●	●	
	Filter Cleaning Indicator		●	●	
	Indoor Temperature Display		●	●	
	Display On/Off	88 Display	●	●	
	Beep On/Off		●	●	
	Auto Changeover		●	●	
Auto Restart		●	●		

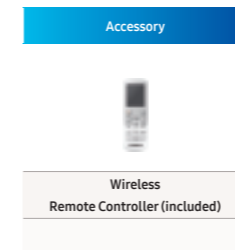

¹Energy labels as shown are according to EU No 626/2011 (LOT10) label classification 2019, on a scale from D to A+++.

Dimensional drawings

Nordic Smart - Indoor

AR09/12NXPDPWKNEE

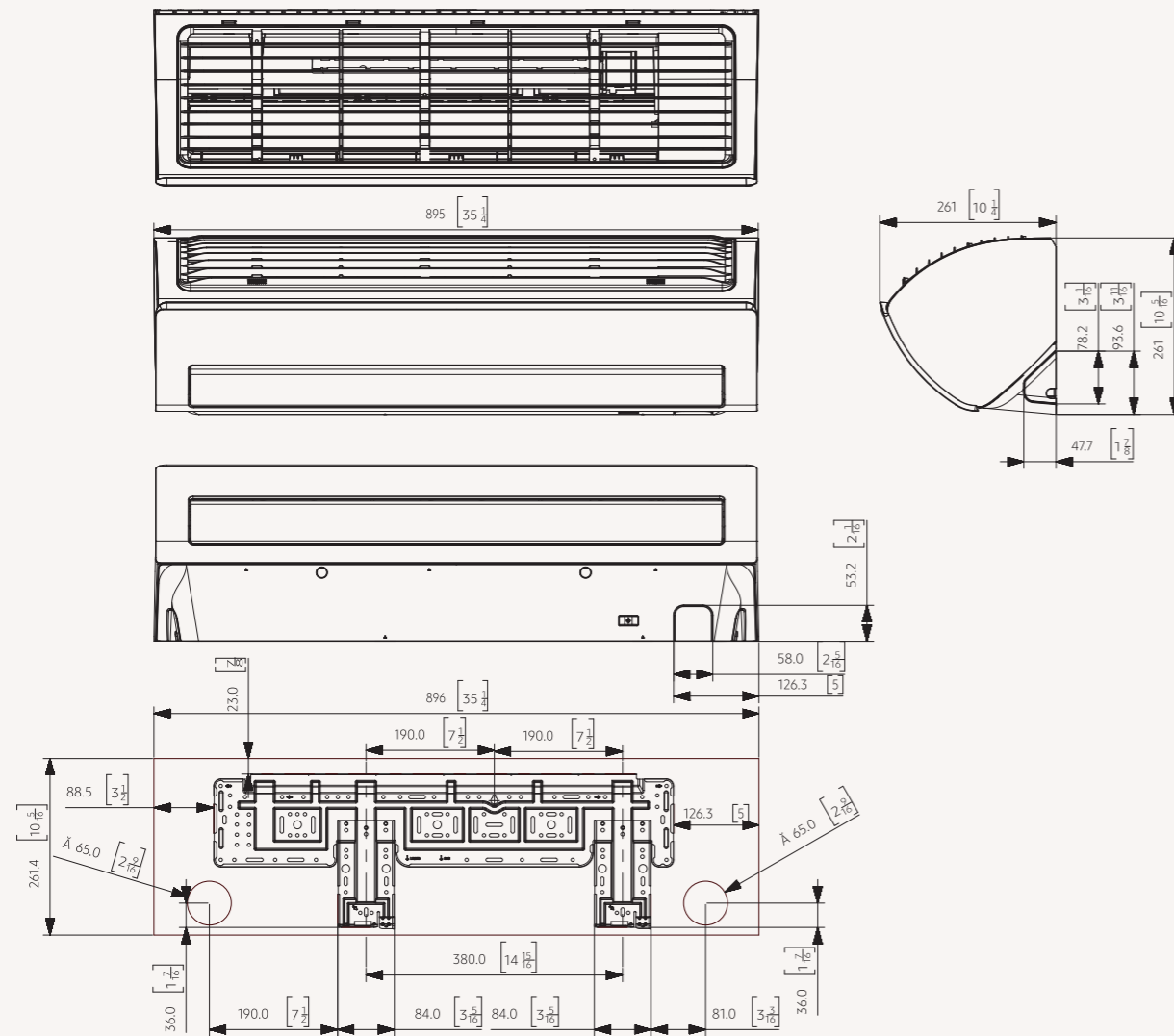

Nordic Smart - Outdoor

AR09/12NXPDPWKNEE

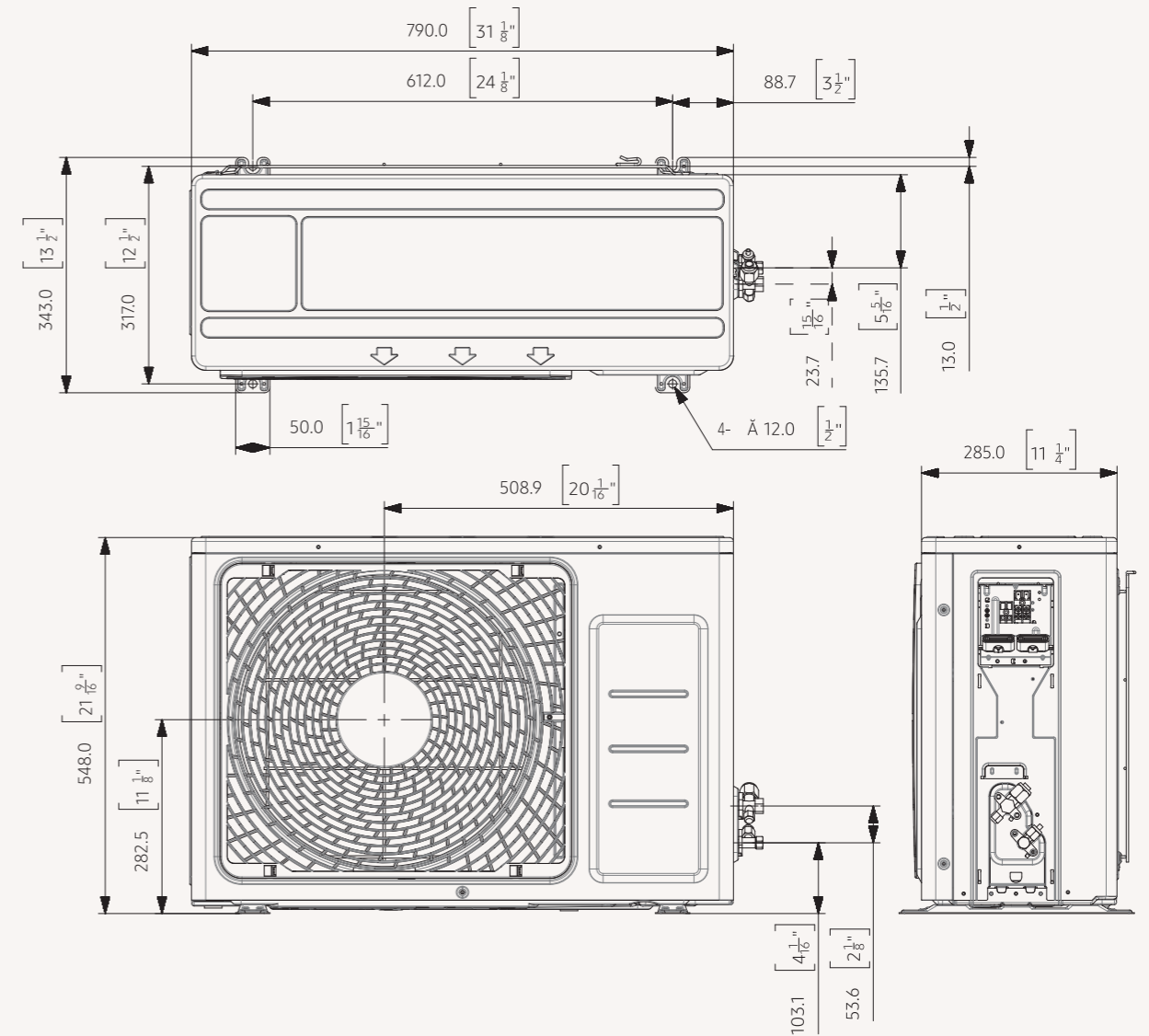

Specifications

Nordic Comfort R32

- Heating down to -30 °C.
- Digital Inverter Compressor.
- 2-Step Cooling mode.
- Easy Filter Plus system.



Indoor Unit		AR09NXFSPWKNEE		AR12NXFSPWKNEE	
Outdoor Unit		AR09NXFSPWKXEE		AR12NXFSPWKXEE	
Capacity					
Capacity	Cooling (Nominal)	kW	2.5	3.5	
	Cooling (Min-Max)	kW	0.9-3.4	0.9-4.2	
	Heating @ +7 °C	kW	3.2	4.0	
	Heating (Min-Max)	kW	0.8-7.0	0.8-7.2	
	Heating @ -5 °C	kW	TBA	TBA	
	Heating @ -10 °C	kW	TBA	TBA	
Performance					
Energy Efficiency Cooling	SEER	W/W	8.5/ A+++	7.7/ A++	
	Power Consumption	kWh/a	103	159	
	Pdesignc	kW	TBA		
	EER	W/W	4.55	3.85	
Energy Efficiency Heating	SCOP	W/W	4.6/ A++	4.5/ A+	
	Power Consumption	kWh/a	700	933	
	Pdesignh (average)	kW	TBA		
	COP ¹	W/W	4.51	4.04	
Moisture Removal		l/h	1.0	1.5	
Maximum Airflow (Cooling)	Indoor Unit	m ³ /min	9.8	10.5	
	Outdoor Unit	m ³ /min	TBA		
Sound Power	Indoor Unit (Cooling)	dB(A)	56	58	
	Outdoor Unit (Cooling)	dB(A)	59	62	
Sound Pressure	Indoor Unit Low/High	dB(A)	17/38	17/40	
	Outdoor Unit High	dB(A)	44	45	
Operating Temperature Range	Cooling	°C	-15-46	-15-46	
	Heating	°C	-25-24	-25-24	
Electrical Data					
Power Source		Φ, V, Hz	1Φ, 220-240 V, 50 Hz	1Φ, 220-240 V, 50 Hz	
Compressor Type	Outdoor Unit	Type	Rotary	Rotary	
Power Consumption	Cooling	W	550	910	
	Heating	W	710	990	
Operating Current	Cooling	A	2.8	4.2	
	Heating	A	3.5	4.6	
Dimensions					
Net Dimensions (W x H x D)	Indoor Unit	mm	896 x 261 x 261	896 x 261 x 261	
	Outdoor Unit	mm	790 x 548 x 285	790 x 548 x 285	
Net Weight	Indoor Unit	kg	10.8	10.8	
	Outdoor Unit	kg	33.6	33.6	
Refrigerant					
Refrigerant	Type		R32 (contains fluorinated greenhouse gases. GWP = 675)		
	Charging (for 5 m)	kg	0.92	0.92	
	Charging Ton Equivalent CO ₂	tCO ₂ e	0.62	0.62	
	Additional Refrigerant Charging	g/m	15	15	
Piping Connections	Liquid Pipe	ø, inch	1/4	1/4	
	Gas Pipe	ø, inch	3/8	3/8	
Piping Length	Min/Max (ODU to IDU)	m	3/15	3/15	
Piping Height	Max	m	8	8	
Piping Connections	Drain Pipe	ø, mm	ID 16	ID 16	



Indoor Unit		AR09NXFSPWKNEE		AR12NXFSPWKNEE	
Outdoor Unit		AR09NXFSPWKXEE		AR12NXFSPWKXEE	
Functions					
Airflow	Wind-Free™ Cooling				
	Air Direction Control (Up/Down)		Auto	Auto	
	Air Direction Control (Left/Right)		Auto	Auto	
Air Purification	Auto Fan Speed		●	●	
	SPI Ioniser		●	●	
	PM 2.5 Filter				
	Easy Filter Plus		●	●	
	Allergy Care		●	●	
Operating Mode	Anti-Bacteria Coating		●	●	
	Auto Clean (Self-Cleaning)		●	●	
	2-Step Cooling		●	●	
	Fast Cooling		●	●	
	Comfort Cooling		●	●	
	Good Sleep		●	●	
Other Functions	Dehumidification		●	●	
	Fan		●	●	
	Quiet		●	●	
	Wi-Fi Control with Samsung SmartThings				
	Filter Cleaning Indicator		●	●	
Accessories	Indoor Temperature Display		●	●	
	Display On/Off	88 Display	●	●	
	Beep On/Off		●	●	
	Auto Changeover		●	●	
	Auto Restart		●	●	

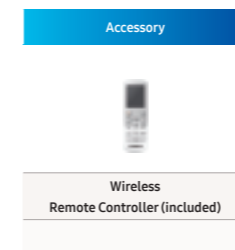

¹Energy labels as shown are according to EU No 626/2011 (LOT10) label classification 2019, on a scale from D to A+++.

Dimensional drawings

Nordic Comfort - Indoor

AR09/12NXFSPWKNEE

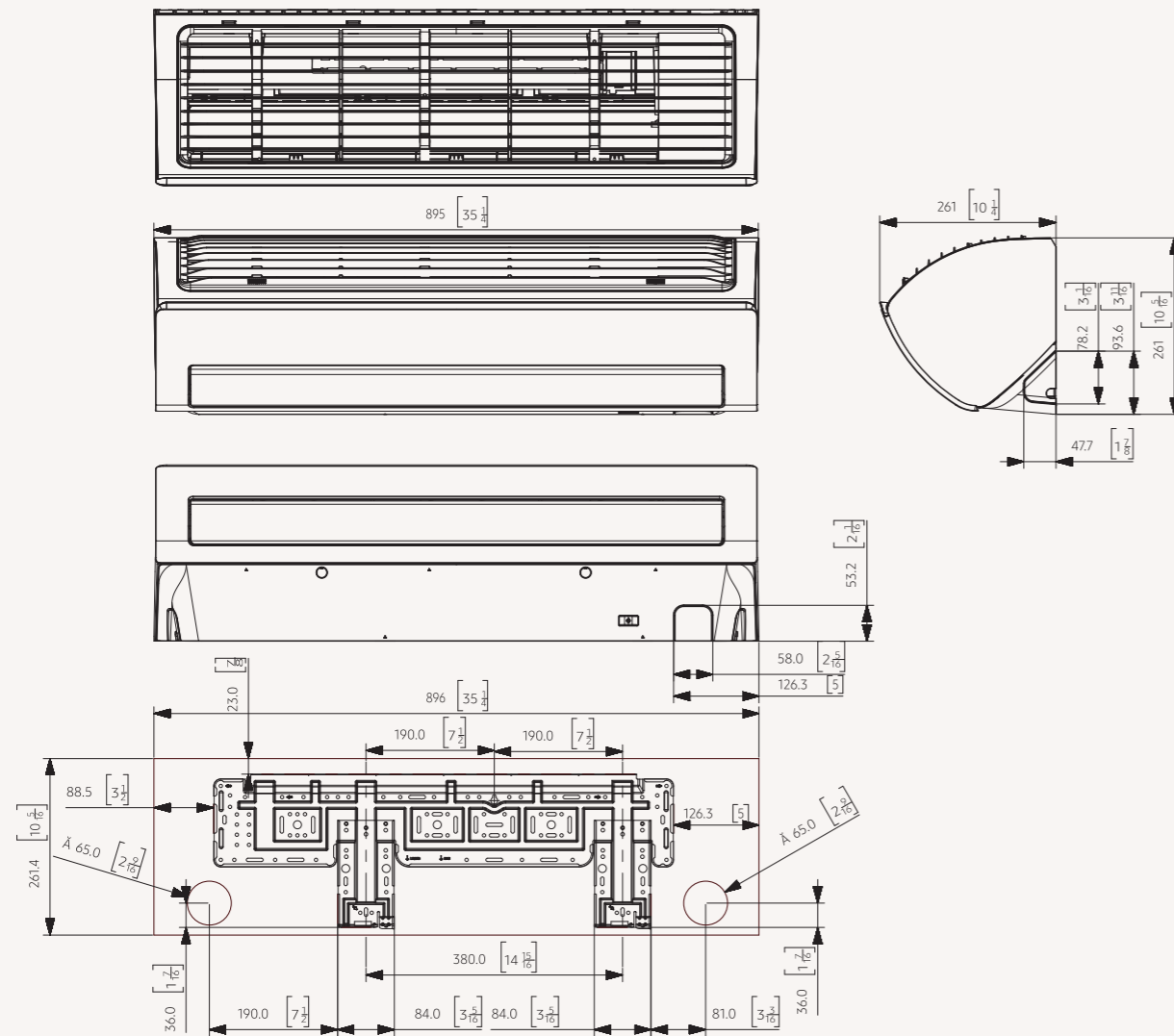

Nordic Comfort - Outdoor

AR09/12NXFSPWKXEE

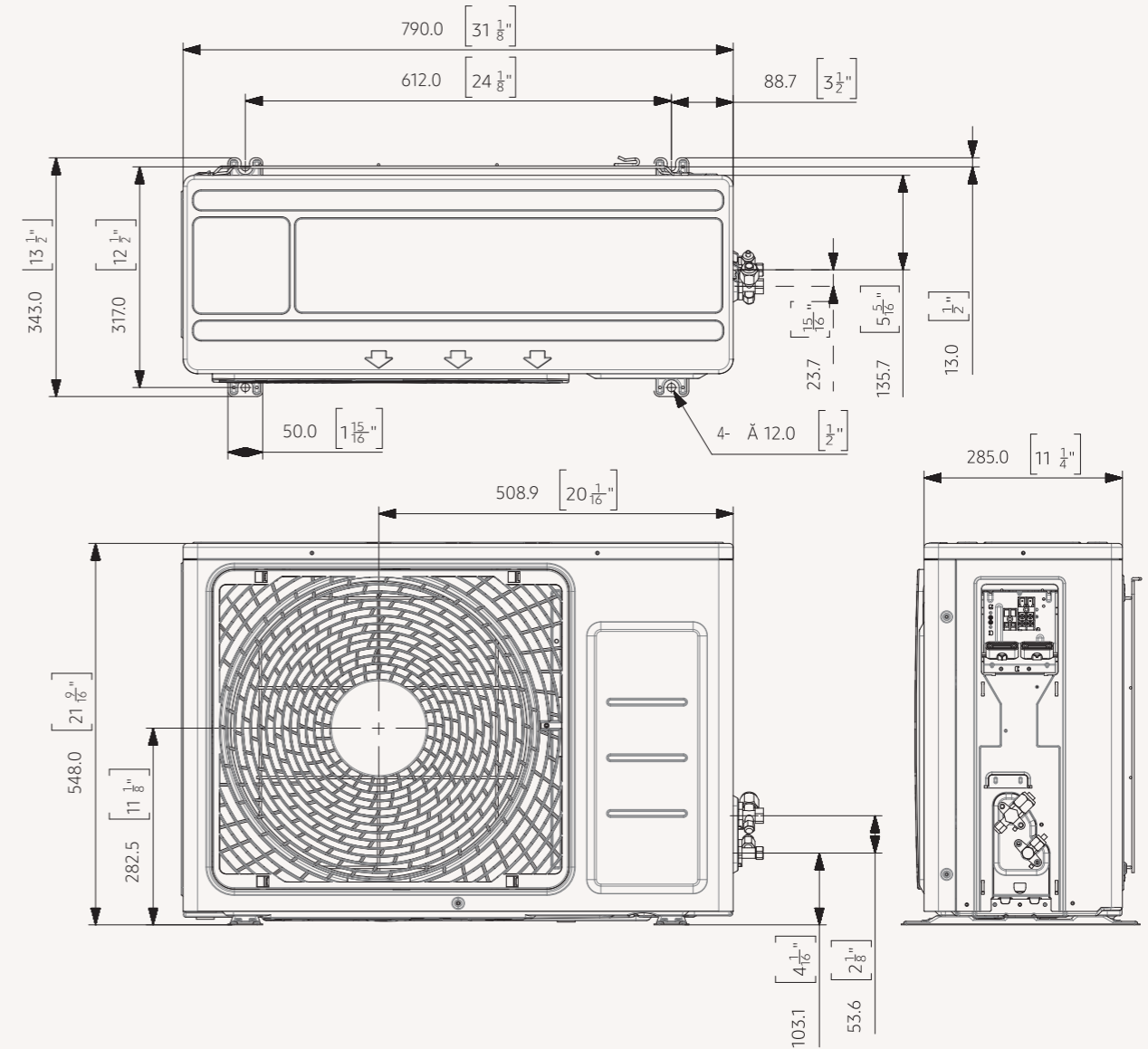

Multi Split



Line-up

Indoor

Model	1.6 kW	2.0 kW	2.5 kW	3.5 kW	5.2 kW	6.8 kW
Wind-Free™ Elite		•	•	•		
Wind-Free™ Avant		•	•	•	•	•
Wind-Free™ Comfort		•	•	•	•	•
Cebu		•	•	•	•	•
Luzon		•	•	•	•	•
Wind-Free™ Mini 4-Way Cassette		•	•	•	•	
Wind-Free™ 1-Way Cassette				•	•	
MSP Duct				•		
LSP Slim Duct		•	•			
Console		•	•	•		

Outdoor



Model	4.0 kW	5.0 kW	5.2 kW	6.8 kW	8.0 kW	10.0 kW
Maximum number of connectable indoor units	2	2	3	3	4	5





Multi Split

Multi Split

Nomenclature

Multi Split - Indoor units

AJ 026 T B N D E G EU

1 2 3 4 5 6 7 8

1	Classification	AJ	Multi Split - Free Joint Multi (FJM)
2	Capacity		x1/10 kW (3 digits)
3	Version	T	2020
4	Product Type	B	Indoor Unit (non-NASA)
		N	Indoor Unit (NASA)
5	Product Notation	N	Wind-Free™ Mini 4-Way Cassette
		1	Wind-Free™ 1-Way Cassette
		M	MSP Duct
		L	Slim Duct
		J	Console
6	Feature	D	Deluxe
7	Voltage Rating	E	1Φ, 220-240 V, 50 Hz
8	Mode	G	Heat Pump (R32)

Multi Split - Outdoor units

AJ 026 T C J 2 E G EU

1 2 3 4 5 6 7 8

1	Classification	AJ	Multi Split - Free Joint Multi (FJM)
2	Capacity		x1/10 kW (3 digits)
3	Version	T	2020
4	Product Type	C	Outdoor Unit (non-NASA)
5	Product Notation	J	FJM
6	Maximum number of connectable indoor units	2	2 Units
		3	3 Units
		4	4 Units
		5	5 Units
7	Voltage Rating	E	1Φ, 220-240 V, 50 Hz
		K	1Φ, 220-240V, 50/60Hz
8	Mode	G	Heat Pump (R32)

Wall-Mounted indoor units for Multi Split follow the same nomenclature as the Residential Wall-Mounted types.



Compatibility guide

FJM 2020 NASA



Model			Wind-Free™ Elite					Wind-Free™ Avant					Wind-Free™ Comfort				
Indoor unit model code			AR07XCAAWKNEU/09/12					AR07XEAAWKNEU/09/12					AR07XFCAWKNEU/09/12/18/24				
Refrigerant type	Outdoor unit model code	Capacity (kW)	2.0	2.5	3.5	2.0	2.5	3.5	5.2	6.8	2.0	2.5	3.5	5.2	6.8		
R32 NASA	AJ040TXJ2KG/EU	4.0	•	•	•	•	•	•			•	•	•				
	AJ050TXJ2KG/EU	5.0	•	•	•	•	•	•	•		•	•	•	•			
	AJ052TXJ3KG/EU	5.2	•	•	•	•	•	•	•		•	•	•	•			
	AJ068TXJ3KG/EU	6.8	•	•	•	•	•	•	•		•	•	•	•			
	AJ080TXJ4KG/EU	8.0	•	•	•	•	•	•	•	•	•	•	•	•	•		
	AJ100TXJ5KG/EU	10.0	•	•	•	•	•	•	•	•	•	•	•	•	•		

FJM 2020 NASA



Model			Cebu					Luzon				
Indoor unit model code			AR07TFYAWKNEU/09/12/18/24					AR07TXHZAWKNEU/09/12/18/24				
Refrigerant type	Outdoor unit model code	Capacity (kW)	2.0	2.5	3.5	5.2	6.8	2.0	2.5	3.5	5.2	6.8
R32 NASA	AJ040TXJ2KG/EU	4.0	•	•	•			•	•	•		
	AJ050TXJ2KG/EU	5.0	•	•	•	•		•	•	•	•	
	AJ052TXJ3KG/EU	5.2	•	•	•	•		•	•	•	•	
	AJ068TXJ3KG/EU	6.8	•	•	•	•		•	•	•	•	
	AJ080TXJ4KG/EU	8.0	•	•	•	•	•	•	•	•	•	•
	AJ100TXJ5KG/EU	10.0	•	•	•	•	•	•	•	•	•	•

Other FJM NASA



Model			Wind-Free™ Mini 4-Way Cassette					Wind-Free™ 1-Way		Slim Duct			Console		
Indoor unit model code			AJ016TNNDKG/EU/20/26/35/52					AJ026TN1DKG/EU/35		AJ026TNLDEG/EU/35/52			AJ026TNJDKG/EU/35/52		
Refrigerant type	Outdoor unit model code	Capacity (kW)	1.6	2.0	2.6	3.5	5.2	2.6	3.5	2.6	3.5	5.2	2.6	3.5	5.2
R32 NASA	AJ040TXJ2KG/EU	4.0						•	•				•	•	
	AJ050TXJ2KG/EU	5.0	•	•	•	•		•	•	•	•		•	•	•
	AJ052TXJ3KG/EU	5.2	•	•	•	•		•	•	•	•		•	•	•
	AJ068TXJ3KG/EU	6.8	•	•	•	•		•	•	•	•	•			
	AJ080TXJ4KG/EU	8.0	•	•	•	•		•	•	•	•	•			
	AJ100TXJ5KG/EU	10.0	•	•	•	•		•	•	•	•	•			

Specifications

Outdoor units R32

- Compressor with Digital Inverter Boost technology.
- Equipped with NASA communication protocol.
- Direct drive fan powered by a BLDC motor.
- Triple Protector Plus to protect compressor, fan and controller from power surges.



Outdoor Unit			AJ040TXJ2KG/EU	AJ050TXJ2KG/EU	AJ052TXJ3KG/EU	AJ068TXJ3KG/EU
Maximum number of connectable indoor units			2	2	3	3
Capacity						
Capacity	Cooling (Nominal)	kW	4.0	5.0	5.2	6.8
	Heating @ +7 °C	kW	4.2	5.6	6.3	8.0
	Heating @ -5 °C	kW	3.16	4.22	4.22	6.02
	Heating @ -10 °C	kW	2.70	3.60	3.60	5.14
	Heating @ -15 °C	kW	2.23	2.98	2.98	4.25
Performance						
Energy Efficiency Cooling	SEER ¹	W/W	8.54	8.54	8.51	7.75
	Power Consumption	kWh/a	164	205	206	293
	Pdesignc	kW	4.0	5.0	5.0	6.5
	EER	W/W	4.44	4.10	4.16	3.78
Energy Efficiency Heating	SCOP ¹	W/W	4.60	4.64	4.60	4.32
	Power Consumption	kWh/a	922	1,270	1,400	1,833
	Pdesignh (average)	kW	3.1	4.2	4.6	5.7
	COP ¹	W/W	4.64	4.38	4.77	4.42
Airflow Rate	m ³ /min	29.7	33.1	38.0	47.5	
Sound Power	dB(A)	60	61	61	64	
Sound Pressure	Cooling	dB(A)	45	46	46	48
	Heating	dB(A)	46	47	48	50
Fan	Type		Propeller Fan	Propeller Fan	Propeller Fan	Propeller Fan
	Discharge direction		Front (horizontal)	Front (horizontal)	Front (horizontal)	Front (horizontal)
	Power	W	40	40	125	125
	Number of Fans	-	1	1	1	1
Operating Temperature Range	Cooling	°C	-5.0~46.0	-5.0~46.0	-10.0~46.0	-10.0~46.0
	Heating	°C	-15~24	-15~24	-15~24	-15~24
Electrical Data						
Power Source	Φ, V, Hz		1Φ, 220~240 V, 50 Hz	1Φ, 220~240 V, 50 Hz	1Φ, 220~240 V, 50 Hz	1Φ, 220~240 V, 50 Hz
Compressor Type			Twin BLDC Rotary	Twin BLDC Rotary	Twin BLDC Rotary	Twin BLDC Rotary
Power Consumption	Cooling	kW	0.90	1.22	1.25	1.80
	Heating	kW	0.90	1.28	1.32	1.81
Operating Current	Cooling	A	4.1	5.6	5.5	8.1
	Heating	A	4.1	5.9	6.1	8.2
Dimensions						
Net Dimensions (W x H x D)	mm		790 x 548 x 285	790 x 548 x 285	880 x 638 x 310	880 x 798 x 310
Net Weight	kg		32.0	33.0	44.5	57.5
Refrigerant						
Refrigerant	Type		R32 (contains fluorinated greenhouse gases. GWP = 675)			
Piping Connections	Liquid Pipe	ø, inch	1/4 x 2	1/4 x 2	1/4 x 3	1/4 x 3
	Gas Pipe	ø, inch	3/8 x 2	3/8 x 2	3/8 x 2 + 1/2	3/8 + 1/2 x 2
	Total Piping Length	m	30	30	50	50
	Min/Max	m	3/25	3/25	3/25	3/25
Piping Height	Max Height (ID-ID)	m	7.5	7.5	7.5	7.5
	Max Height (OD-ID)	m	15	15	15	15

Outdoor Unit			AJ080TXJ4KG/EU	AJ100TXJ5KG/EU
Maximum number of connectable indoor units			4	5
Capacity				
Capacity	Cooling (Nominal)	kW	8.0	10.0
	Heating @ +7 °C	kW	9.3	12.0
	Heating @ -5 °C	kW	7.00	9.03
	Heating @ -10 °C	kW	5.97	7.70
	Heating @ -15 °C	kW	4.94	6.38
Performance				
Energy Efficiency Cooling	SEER ¹	W/W	7.75	8.00
	Power Consumption	kWh/a	330	TBA
	Pdesignc	kW	7.3	TBA
	EER	W/W	4.06	3.64
Energy Efficiency Heating	SCOP ¹	W/W	4.10	4.32
	Power Consumption	kWh/a	2,009	TBA
	Pdesignh (average)	kW	5.9	TBA
	COP ¹	W/W	4.37	4.26
Airflow Rate	m ³ /min	47.5	75.0	
Sound Power	dB(A)	64	70	
Sound Pressure	Cooling	dB(A)	48	54
	Heating	dB(A)	50	56
Fan	Type		Propeller Fan	Propeller Fan
	Discharge direction		Front (horizontal)	Front (horizontal)
	Power	W	125	125
	Number of Fans	-	1	1
Operating Temperature Range	Cooling	°C	-10.0~46.0	-10.0~46.0
	Heating	°C	-15~24	-15~24
Electrical Data				
Power Source	Φ, V, Hz		1Φ, 220~240 V, 50 Hz	1Φ, 220~240 V, 50 Hz
Compressor Type			Twin BLDC Rotary	Twin BLDC Rotary
Power Consumption	Cooling	kW	1.97	2.75
	Heating	kW	2.13	2.82
Operating Current	Cooling	A	8.9	12.2
	Heating	A	9.5	12.8
Dimensions				
Net Dimensions (W x H x D)	mm		880 x 798 x 310	940 x 998 x 330
Net Weight	kg		57.5	76.5
Refrigerant				
Refrigerant	Type		R32 (contains fluorinated greenhouse gases. GWP = 675)	
Piping Connections	Liquid Pipe	ø, inch	1/4 x 4	1/4 x 5
	Gas Pipe	ø, inch	3/8 x 2 + 1/2 x 2	3/8 x 2 + 1/2 x 3
	Total Piping Length	m	70	75
	Min/Max	m	3/25	3/25
Piping Height	Max Height (ID-ID)	m	7.5	7.5
	Max Height (OD-ID)	m	15	15

¹Energy labels as shown are according to EU No 626/2011 (LOT10) label classification 2019, on a scale from D to A+++.

Dimensional drawings

Outdoor units

AJ040/50TXJ2KG/EU

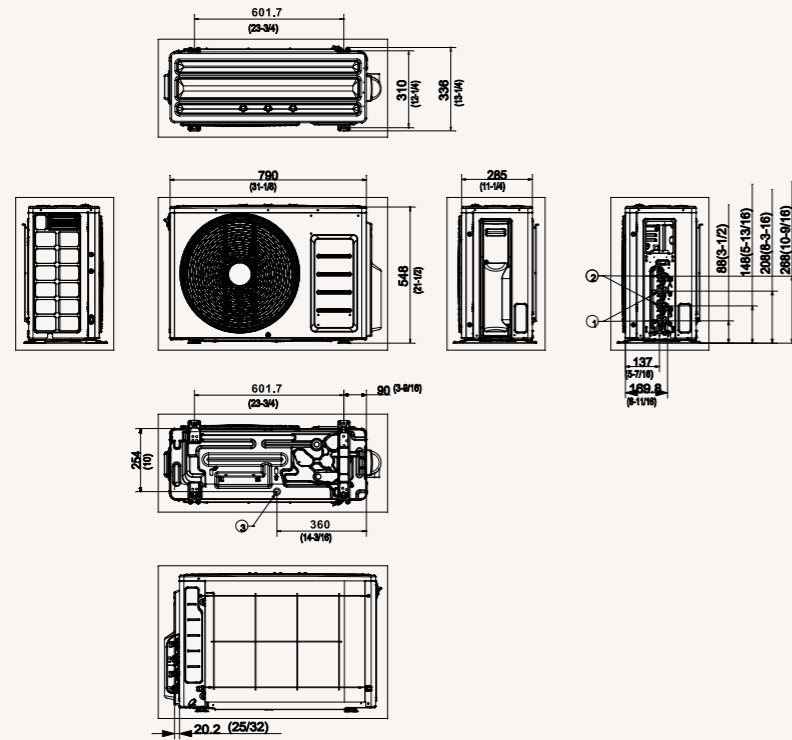

AJ068/80TXJ3EG/EU

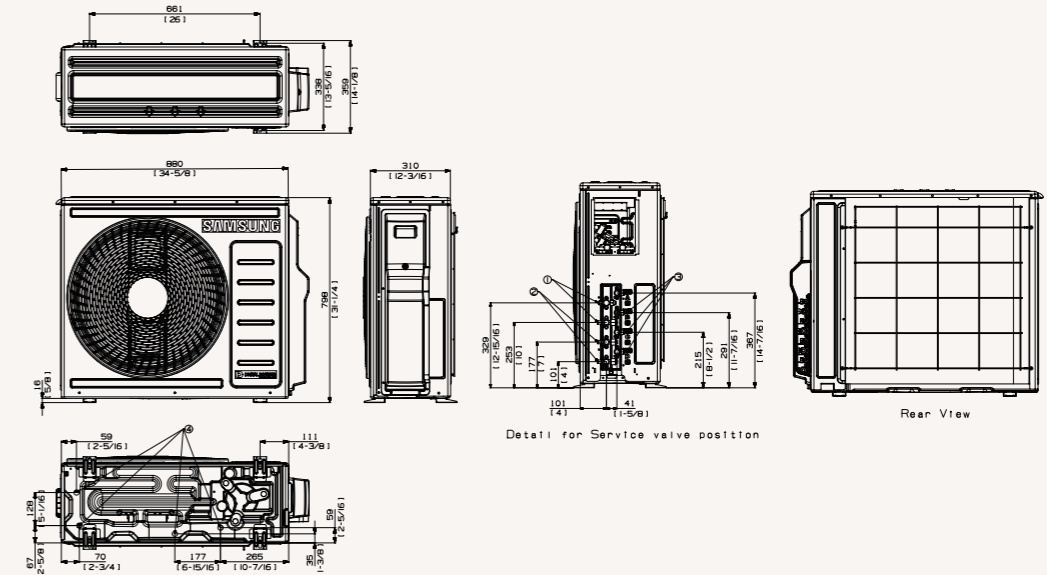

AJ052TXJ3KG

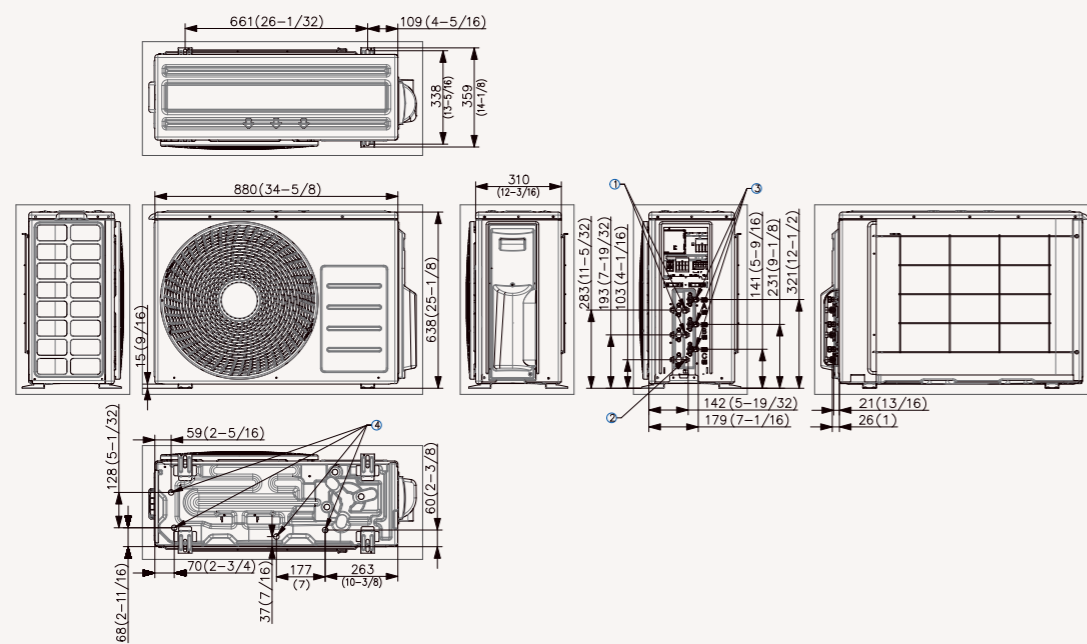

AJ100TXJ5EG/EU

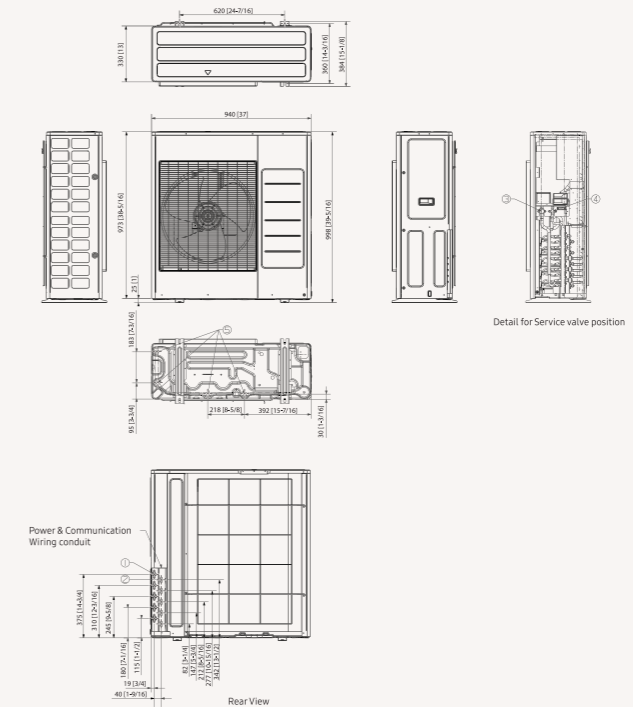

Multi Split

Multi Split

Specifications

Wind-Free™ Elite R32

- Three-step cooling: Fast Cooling mode, Dehumidification mode and Wind-Free™ Cooling mode.
- Tri-Care Filter system with Zeolite Coating.
- AI Auto Comfort and Motion Detect Sensor.
- Wi-Fi Control with Samsung SmartThings and Bixby voice controls.



Indoor Unit			AR07TXCAAWKNEU	AR09TXCAAWKNEU	AR12TXCAAWKNEU
Capacity					
Capacity	Cooling	kW	2.0	2.5	3.5
	Heating @ +7 °C	kW	2.2	3.2	4.0
Performance					
Moisture Removal		l/h	TBA	1.0	1.5
Airflow Rate		m ³ /min	10.7	11.1	12.1
Sound Power	Cooling	dB(A)	56	56	58
	Sound Pressure	H/L	37/19	39/16	40/16
Electrical Data					
Power Source		Φ, V, Hz	1Φ, 220-240 V, 50 Hz	1Φ, 220-240 V, 50 Hz	1Φ, 220-240 V, 50 Hz
Power Consumption	Cooling	W	40	40	40
	Heating	W	40	40	40
Current Input	Cooling	A	0.4	0.4	0.4
	Heating	A	0.4	0.4	0.4
Dimensions					
Net Dimensions (W x H x D)		mm	889 x 299 x 215	889 x 299 x 215	889 x 299 x 215
Net Weight		kg	10.3	10.3	10.3
Refrigerant					
Piping Connections	Liquid Pipe	ø, inch	1/4	1/4	1/4
	Gas Pipe	ø, inch	3/8	3/8	3/8
Piping Connections	Drain Pipe	ø, mm	ID 16	ID 16	ID 16



Indoor Unit			AR07TXCAAWKNEU	AR09TXCAAWKNEU	AR12TXCAAWKNEU
Functions					
Airflow	Wind-Free™ Cooling		●	●	●
	Air Direction Control (Up/Down)		Auto	Auto	Auto
	Air Direction Control (Left/Right)		Auto	Auto	Auto
	Auto Fan Speed		●	●	●
Air Purification	Tri-Care Filter		●	●	●
	Easy Filter Plus		●	●	●
	Auto Clean (Self-Cleaning)		●	●	●
Operating Mode	AI Auto Comfort with Wi-Fi & MDS (direct/indirect)		●	●	●
	AI Auto Comfort with Wi-Fi		●	●	●
	Auto Mode (without Wi-Fi)				
	Fast Cooling		●	●	●
	Good Sleep		●	●	●
	Eco		●	●	●
	Dehumidification		●	●	●
	Fan		●	●	●
	Quiet		●	●	●
	Other Functions	Samsung SmartThings		●	●
MDS (Motion Detect Sensor)		●	●	●	
Indoor Temperature Display	88 Display		●	●	●
Display On/Off			●	●	●
Beep On/Off			●	●	●
Auto Changeover			●	●	●
Auto Restart			●	●	●

Accessory



Wireless Controller (included)

Dimensional drawings

Wind-Free™ Elite

AR07/09TXCAWKNEU

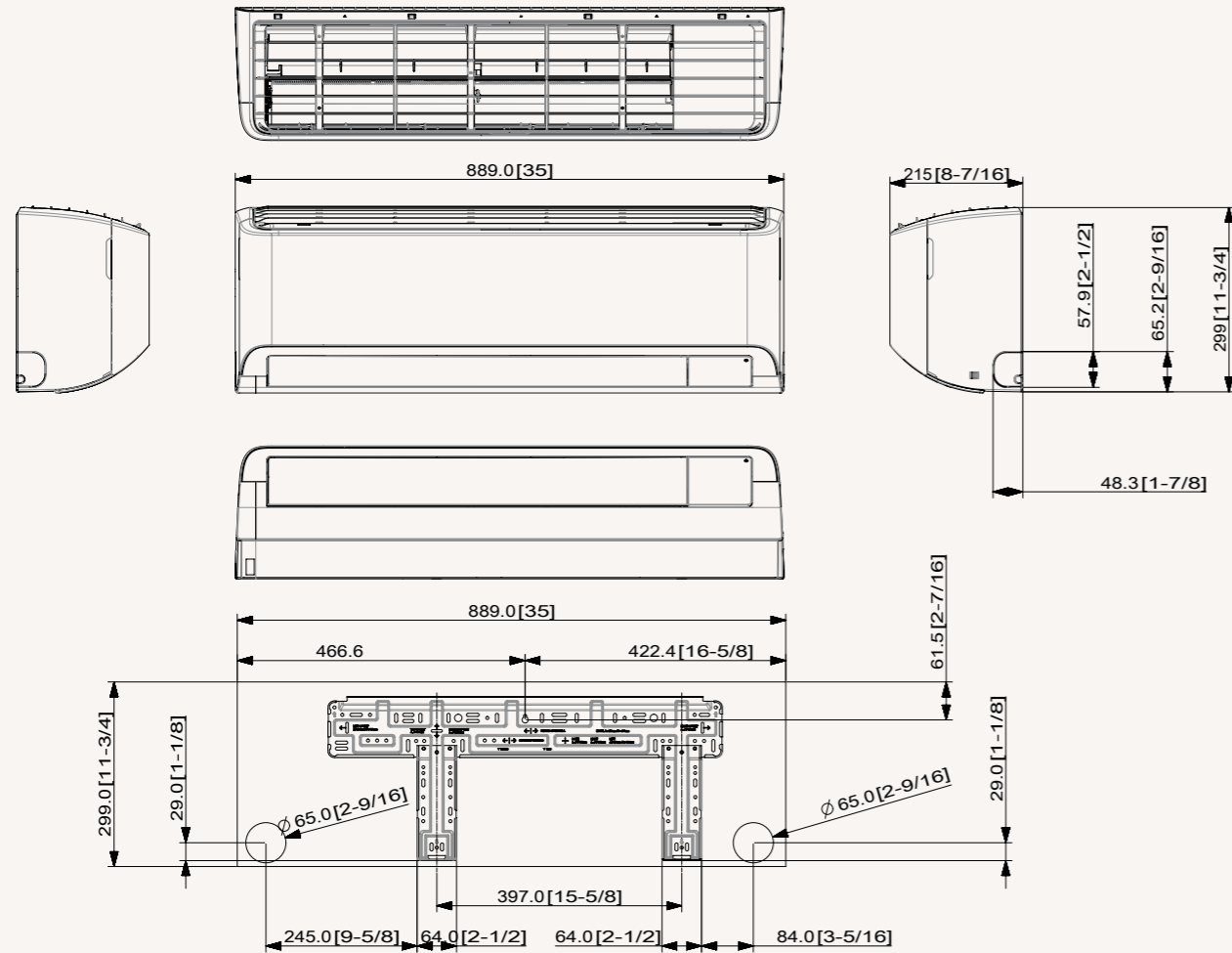

AR12TXCAWKNEU

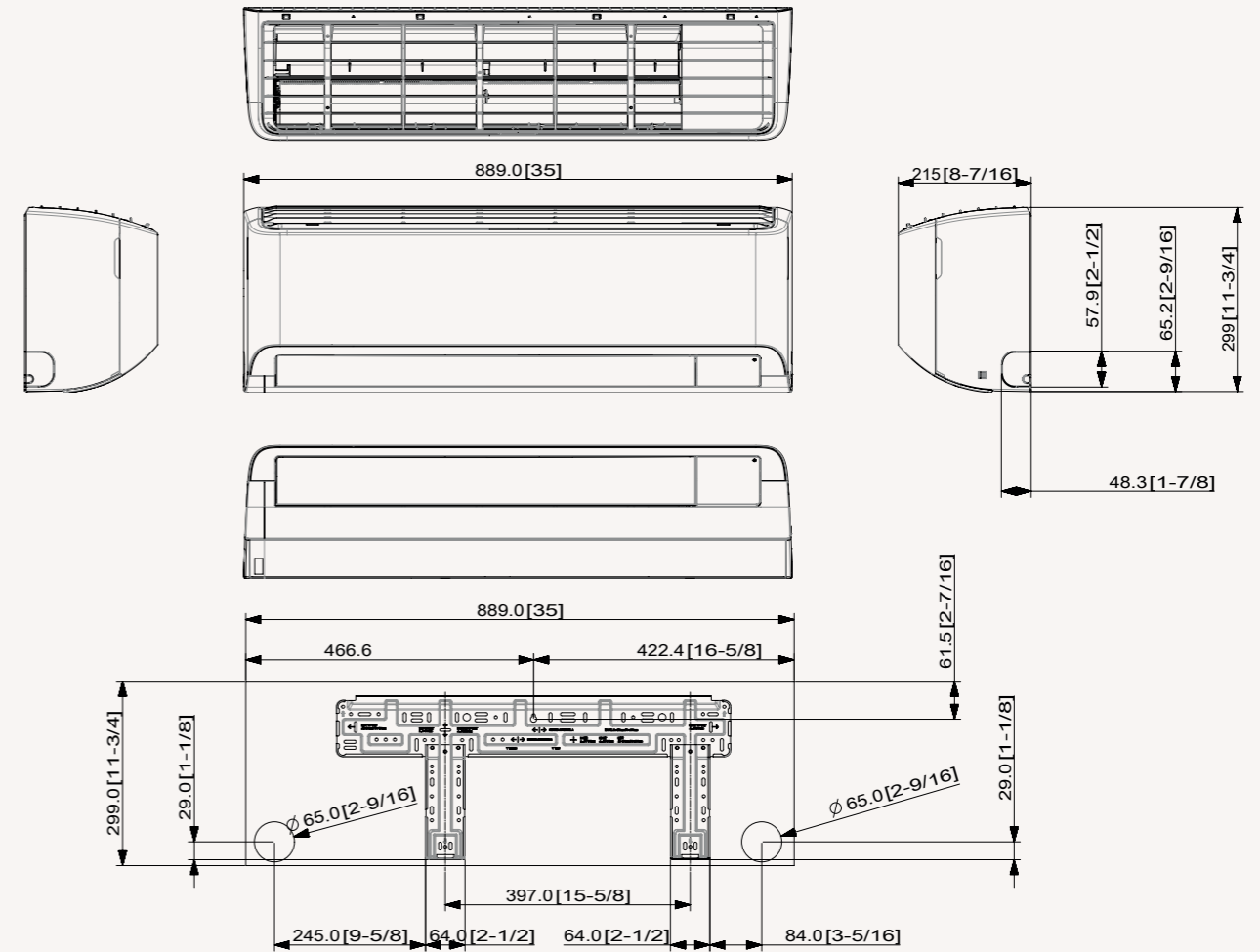

Multi Split

Multi Split

Specifications

Wind-Free™ Avant  

- Three-step cooling: Fast Cooling mode, Dehumidification mode and Wind-Free™ Cooling mode.
- Tri-Care Filter system with Zeolite Coating.
- AI Auto Comfort.
- Wi-Fi Control with Samsung SmartThings and Bixby voice controls.



Indoor Unit		AR07XEAAWKNEU	AR09XEAAWKNEU	AR12XEAAWKNEU	AR18XEAAWKNEU	
Capacity						
Capacity	Cooling	kW	2.0	2.5	3.5	5.0
	Heating @ +7 °C	kW	2.2	3.2	4.0	6.0
Performance						
Moisture Removal		l/h	TBA	1.0	1.5	2.0
Airflow Rate		m ³ /min	10.7	9.5	10.5	15.7
Sound Power	Cooling	dB(A)	56	57	57	58
	H/L	dB(A)	37/19	38/16	40/16	41/25
Electrical Data						
Power Source		Φ, V, Hz	1Φ, 220-240 V, 50 Hz	1Φ, 220-240 V, 50 Hz	1Φ, 220-240 V, 50 Hz	1Φ, 220-240 V, 50 Hz
Power Consumption	Cooling	W	40	40	40	40
	Heating	W	40	40	40	40
Current Input	Cooling	A	0.4	0.4	0.4	0.4
	Heating	A	0.4	0.4	0.4	7.8
Dimensions						
Net Dimensions (W x H x D)		mm	828 x 267 x 265	828 x 267 x 265	828 x 267 x 265	1,065 x 301 x 311
Net Weight		kg	9.4	9.4	9.4	13.2
Refrigerant						
Piping Connections	Liquid Pipe	ø, inch	1/4	1/4	1/4	1/4
	Gas Pipe	ø, inch	3/8	3/8	3/8	1/2
Piping Connections	Drain Pipe	ø, mm	ID 16	ID 16	ID 16	ID 16
Functions						
Airflow	Wind-Free™ Cooling		●	●	●	●
	Air Direction Control (Up/Down)		Auto	Auto	Auto	Auto
	Air Direction Control (Left/Right)		Auto	Auto	Auto	Auto
	Auto Fan Speed		●	●	●	●
Air Purification	Tri-Care Filter		●	●	●	●
	Easy Filter Plus		●	●	●	●
	Auto Clean (Self-Cleaning)		●	●	●	●
Operating Mode	AI Auto Comfort with Wi-Fi & MDS (direct/indirect)		●	●	●	●
	AI Auto Comfort with Wi-Fi		●	●	●	●
	Auto Mode (without Wi-Fi)		●	●	●	●
	Fast Cooling		●	●	●	●
	Good Sleep		●	●	●	●
	Eco		●	●	●	●
	Dehumidification		●	●	●	●
	Fan		●	●	●	●
	Quiet		●	●	●	●
	Other Functions	Samsung SmartThings		●	●	●
MDS (Motion Detect Sensor)		●	●	●	●	
Indoor Temperature Display	88 Display		●	●	●	●
Display On/Off			●	●	●	●
Beep On/Off			●	●	●	●
Auto Changeover			●	●	●	●
Auto Restart			●	●	●	●

Indoor Unit		AR24XEAAWKNEU	
Capacity			
Capacity	Cooling	kW	6.5
	Heating @ +7 °C	kW	7.4
Performance			
Moisture Removal		l/h	2.5
Airflow Rate		m ³ /min	17.6
Sound Power	Cooling	dB(A)	62
	H/L	dB(A)	45/26
Electrical Data			
Power Source		Φ, V, Hz	1Φ, 220-240 V, 50 Hz
Power Consumption	Cooling	W	40
	Heating	W	40
Current Input	Cooling	A	0.4
	Heating	A	0.4
Dimensions			
Net Dimensions (W x H x D)		mm	1,065 x 301 x 311
Net Weight		kg	13.4
Refrigerant			
Piping Connections	Liquid Pipe	ø, inch	1/4
	Gas Pipe	ø, inch	5/8
Piping Connections	Drain Pipe	ø, mm	ID 16
Functions			
Airflow	Wind-Free™ Cooling		●
	Air Direction Control (Up/Down)		Auto
	Air Direction Control (Left/Right)		Auto
	Auto Fan Speed		●
Air Purification	Tri-Care Filter		●
	Easy Filter Plus		●
	Auto Clean (Self-Cleaning)		●
Operating Mode	AI Auto Comfort with Wi-Fi & MDS (direct/indirect)		●
	AI Auto Comfort with Wi-Fi		●
	Auto Mode (without Wi-Fi)		●
	Fast Cooling		●
	Good Sleep		●
	Eco		●
	Dehumidification		●
	Fan		●
	Quiet		●
	Other Functions	Samsung SmartThings	
MDS (Motion Detect Sensor)		●	
Indoor Temperature Display	88 Display		●
Display On/Off			●
Beep On/Off			●
Auto Changeover			●
Auto Restart			●

Accessory



Wireless Remote Controller (included)

Dimensional drawings

Wind-Free™ Avant

AR07/09/12TXEAAWKNEU

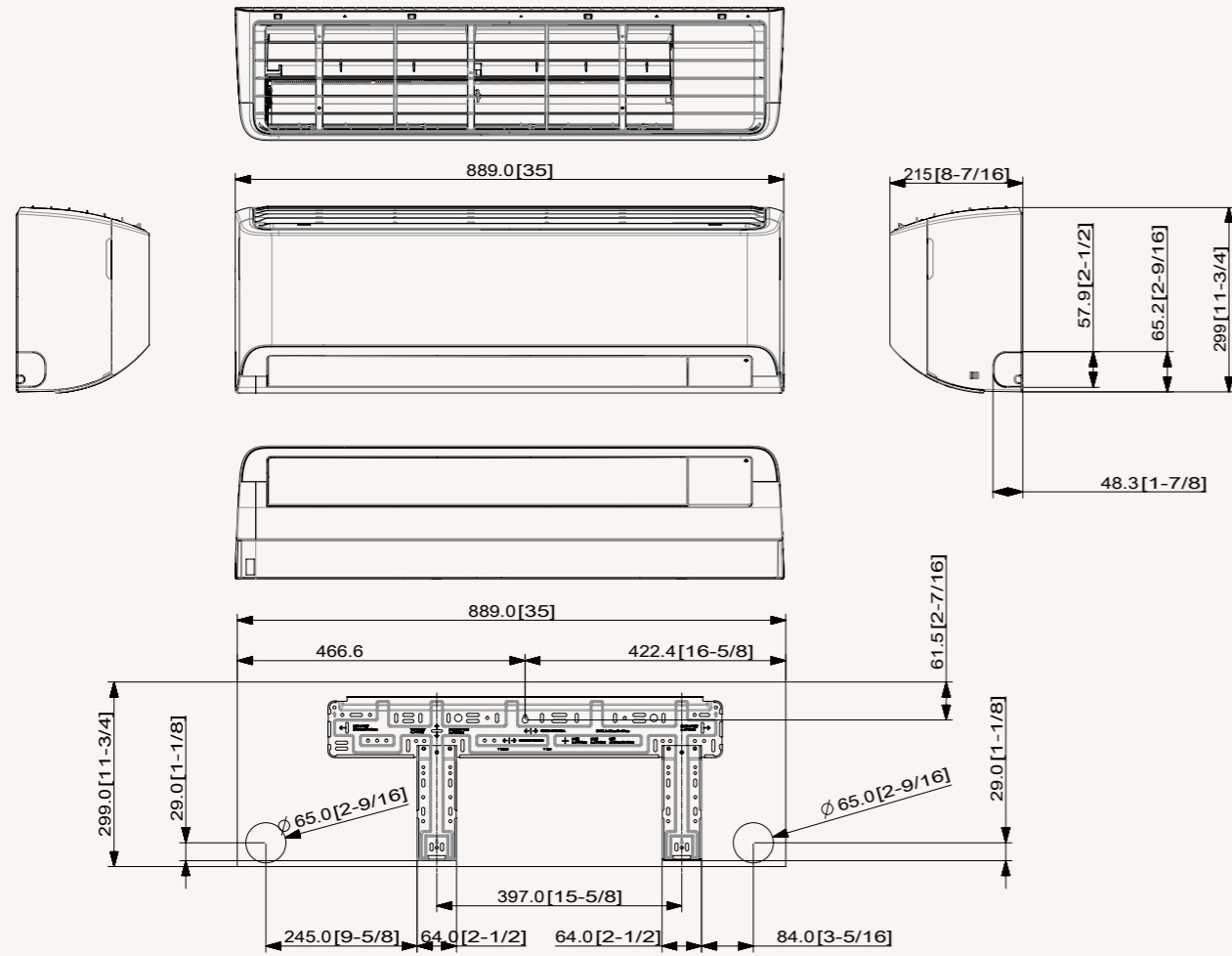

AR18/24TXEAAWKNEU

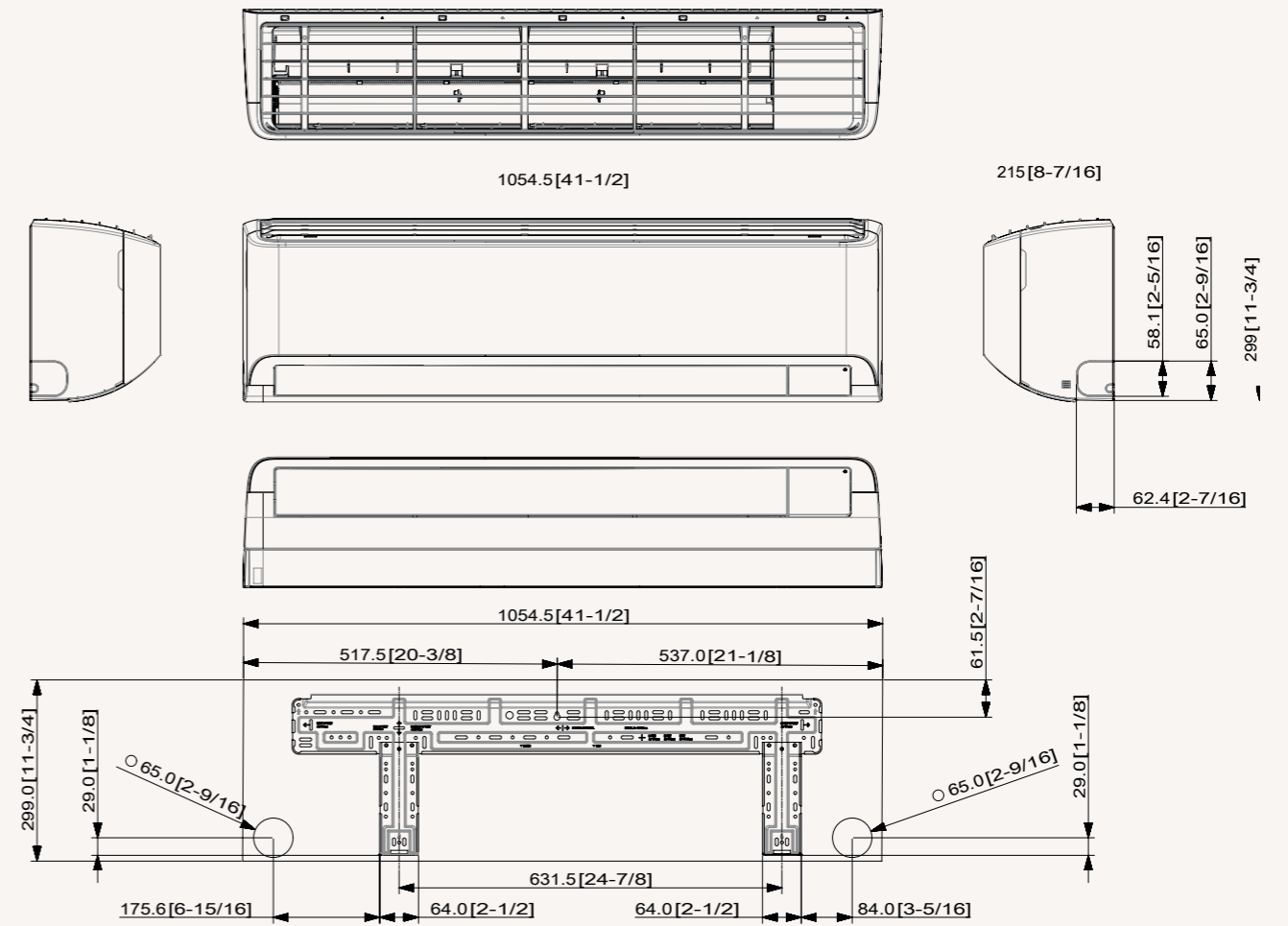

Specifications

Wind-Free™ Comfort R32

- Three-step cooling: Fast Cooling mode, Dehumidification mode and Wind-Free™ Cooling mode.
- AI Auto Comfort.
- Wi-Fi Control with Samsung SmartThings and Bixby voice controls.



Indoor Unit			AR07TXFAWKNEU	AR09TXFAWKNEU	AR12TXFAWKNEU	AR18TXFAWKNEU
Capacity						
Capacity	Cooling	kW	2.0	2.5	3.5	5.0
	Heating @ +7 °C	kW	2.2	3.2	3.5	6.0
Performance						
Moisture Removal		l/h	TBA	1.0	1.5	2.0
Airflow Rate		m ³ /min	9.9	10.3	10.7	16.6
Sound Power	Cooling	dB(A)	54	54	56	58
	H/L	dB(A)	36/19	37/19	38/19	41/25
Electrical Data						
Power Source		Φ, V, Hz	1Φ, 220-240 V, 50 Hz	1Φ, 220-240 V, 50 Hz	1Φ, 220-240 V, 50 Hz	1Φ, 220-240 V, 50 Hz
Power Consumption	Cooling	W	30	30	30	TBA
	Heating	W	30	30	30	TBA
Current Input	Cooling	A	0.3	0.3	0.3	TBA
	Heating	A	0.3	0.3	0.3	TBA
Dimensions						
Net Dimensions (W x H x D)		mm	820 x 299 x 215	820 x 299 x 215	820 x 299 x 215	1,055 x 299 x 215
Net Weight		kg	8.9	8.9	8.9	12.2
Refrigerant						
Piping Connections	Liquid Pipe	ø, inch	1/4	1/4	1/4	1/4
	Gas Pipe	ø, inch	3/8	3/8	3/8	1/2
Piping Connections	Drain Pipe	ø, mm	ID 16	ID 16	ID 16	ID 16
Functions						
Airflow	Wind-Free™ Cooling		●	●	●	●
	Air Direction Control (Up/Down)		Auto	Auto	Auto	Auto
	Air Direction Control (Left/Right)		Auto	Auto	Auto	Auto
	Auto Fan Speed		●	●	●	●
Air Purification	Tri-Care Filter		●	●	●	●
	Easy Filter Plus		●	●	●	●
	Auto Clean (Self-Cleaning)		●	●	●	●
Operating Mode	AI Auto Comfort with Wi-Fi & MDS (direct/indirect)		●	●	●	●
	AI Auto Comfort with Wi-Fi		●	●	●	●
	Auto Mode (without Wi-Fi)		●	●	●	●
	Fast Cooling		●	●	●	●
	Good Sleep		●	●	●	●
	Eco		●	●	●	●
	Dehumidification		●	●	●	●
	Fan		●	●	●	●
	Quiet		●	●	●	●
Other Functions	Samsung SmartThings		●	●	●	●
	MDS (Motion Detect Sensor)		●	●	●	●
	Indoor Temperature Display	88 Display	●	●	●	●
	Display On/Off		●	●	●	●
	Beep On/Off		●	●	●	●
	Auto Changeover		●	●	●	●
Auto Restart		●	●	●	●	

Indoor Unit			AR24TXFAWKNEU
Capacity			
Capacity	Cooling	kW	6.5
	Heating @ +7 °C	kW	7.4
Performance			
Moisture Removal		l/h	2.5
Airflow Rate		m ³ /min	18.6
Sound Power	Cooling	dB(A)	TBA
	H/L	dB(A)	TBA
Electrical Data			
Power Source		Φ, V, Hz	1Φ, 220-240 V, 50 Hz
Power Consumption	Cooling	W	TBA
	Heating	W	TBA
Current Input	Cooling	A	TBA
	Heating	A	TBA
Dimensions			
Net Dimensions (W x H x D)		mm	1,055 x 299 x 215
Net Weight		kg	12.2
Refrigerant			
Piping Connections	Liquid Pipe	ø, inch	1/4
	Gas Pipe	ø, inch	5/8
Piping Connections	Drain Pipe	ø, mm	ID 16
Functions			
Airflow	Wind-Free™ Cooling		●
	Air Direction Control (Up/Down)		Auto
	Air Direction Control (Left/Right)		Auto
	Auto Fan Speed		●
Air Purification	Tri-Care Filter		●
	Easy Filter Plus		●
	Auto Clean (Self-Cleaning)		●
Operating Mode	AI Auto Comfort with Wi-Fi & MDS (direct/indirect)		●
	AI Auto Comfort with Wi-Fi		●
	Auto Mode (without Wi-Fi)		●
	Fast Cooling		●
	Good Sleep		●
	Eco		●
	Dehumidification		●
	Fan		●
	Quiet		●
Other Functions	Samsung SmartThings		●
	MDS (Motion Detect Sensor)		●
	Indoor Temperature Display	88 Display	●
	Display On/Off		●
	Beep On/Off		●
	Auto Changeover		●

Accessory



Wireless Remote Controller (included)

Dimensional drawings

Wind-Free™ Comfort

AR07/09/12TXFCWKNEU

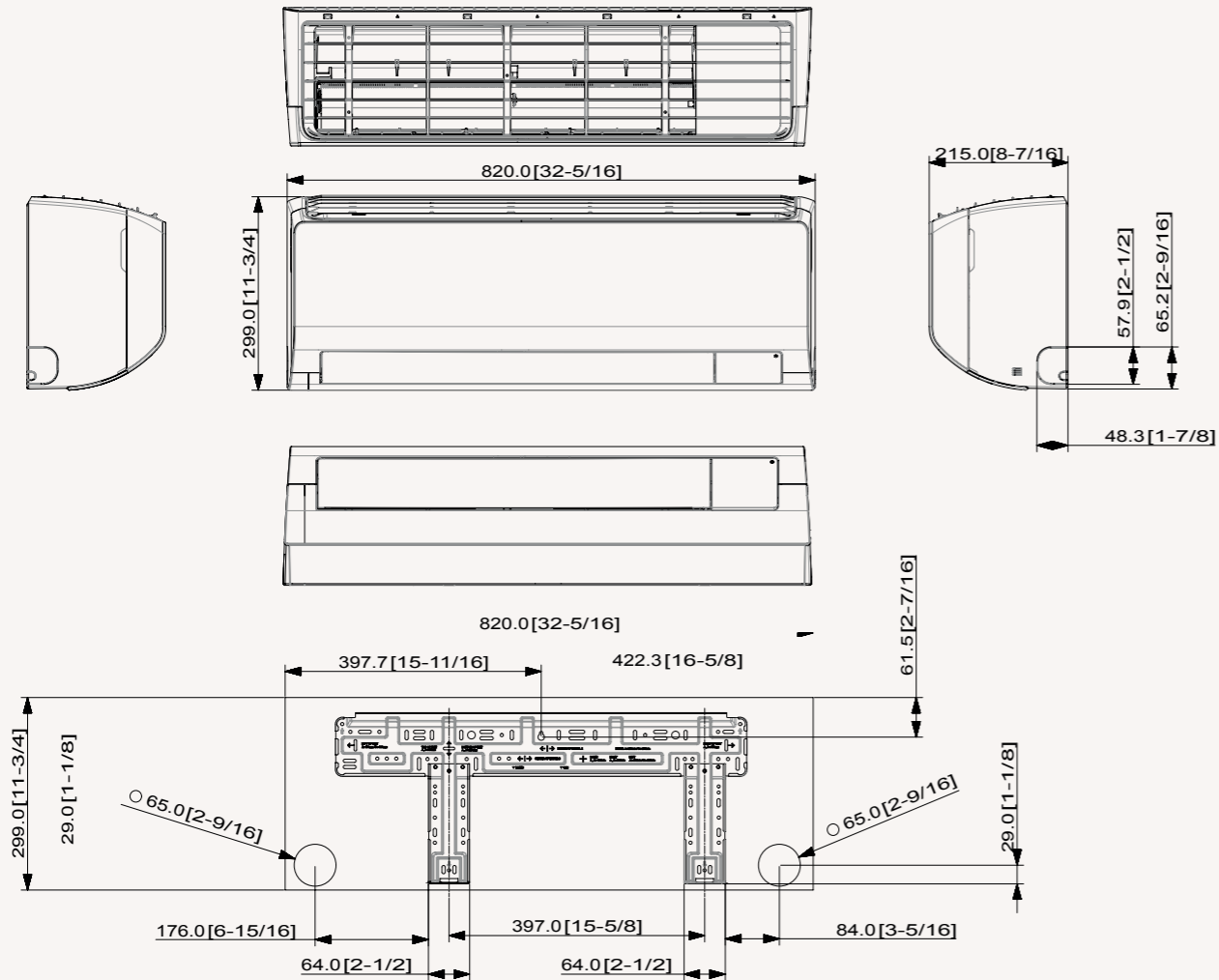

AR18/24TXFCWKNEU

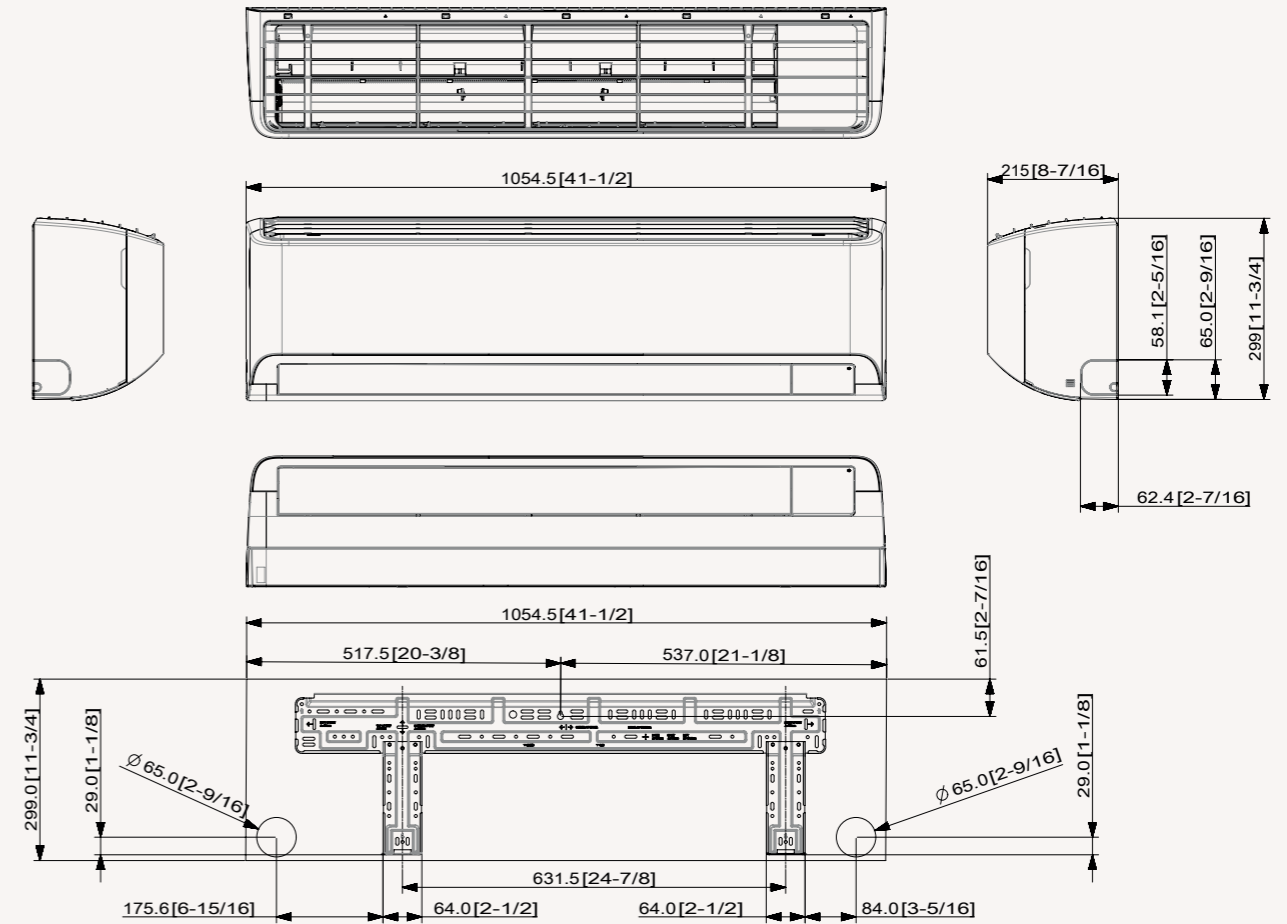

Specifications

Cebu **R32**

- AI Auto Comfort.
- Wi-Fi Control with Samsung SmartThings and Bixby voice controls.



Indoor Unit		AR07TXFYAWKNEU	AR09TXFYAWKNEU	AR12TXFYAWKNEU	AR18TXFYAWKNEU	
Capacity						
Capacity	Cooling	kW	2.0	2.5	3.5	5.0
	Heating @ +7 °C	kW	2.2	3.2	3.5	6.0
Performance						
Moisture Removal		l/h	-	1.0	1.5	2.0
Airflow Rate		m ³ /min	9.9	10.5	10.9	16.5
Sound Power	Cooling	dB(A)	54	TBA	TBA	58
	Sound Pressure	H/L	dB(A)	36/19	TBA	TBA
Electrical Data						
Power Source		Φ, V, Hz	1Φ, 220~240 V, 50 Hz	1Φ, 220~240 V, 50 Hz	1Φ, 220~240 V, 50 Hz	1Φ, 220~240 V, 50 Hz
Power Consumption	Cooling	W	30	30	30	TBA
	Heating	W	30	30	30	TBA
Current Input	Cooling	A	0.3	0.3	0.3	TBA
	Heating	A	0.3	0.3	0.3	TBA
Dimensions						
Net Dimensions (W x H x D)		mm	820 x 299 x 215	820 x 299 x 215	820 x 299 x 215	1,055 x 299 x 215
Net Weight		kg	8.9	8.9	8.9	12.2
Refrigerant						
Piping Connections	Liquid Pipe	ø, inch	1/4	1/4	1/4	1/4
	Gas Pipe	ø, inch	3/8	3/8	3/8	1/2
Piping Connections	Drain Pipe	ø, mm	ID 16	ID 16	ID 16	ID 16
Functions						
Airflow	Wind-Free™ Cooling					
	Air Direction Control (Up/Down)		Auto	Auto	Auto	Auto
	Air Direction Control (Left/Right)		Manual	Manual	Manual	Manual
	Auto Fan Speed		●	●	●	●
Air Purification	Tri-Care Filter		●	●	●	●
	Easy Filter Plus		●	●	●	●
	Auto Clean (Self-Cleaning)		●	●	●	●
Operating Mode	AI Auto Comfort with Wi-Fi & MDS (direct/indirect)					
	AI Auto Comfort with Wi-Fi		●	●	●	●
	Auto Mode (without Wi-Fi)					
	Fast Cooling		●	●	●	●
	Good Sleep		●	●	●	●
	Eco		●	●	●	●
	Dehumidification		●	●	●	●
	Fan		●	●	●	●
	Quiet		●	●	●	●
Other Functions	Samsung SmartThings		●	●	●	●
	MDS (Motion Detect Sensor)					
	Indoor Temperature Display	88 Display	●	●	●	●
	Display On/Off		●	●	●	●
	Beep On/Off		●	●	●	●
	Auto Changeover		●	●	●	●
	Auto Restart		●	●	●	●

AR24TXFYAWKNEU		
Capacity		
Capacity	kW	
Cooling	6.5	
Heating @ +7 °C	7.4	
Performance		
Moisture Removal	l/h	
	2.5	
Airflow Rate	m ³ /min	
	18.4	
Sound Power	Cooling	dB(A)
		TBA
Sound Pressure	H/L	dB(A)
		TBA
Electrical Data		
Power Source	Φ, V, Hz	
	1Φ, 220~240 V, 50 Hz	
Power Consumption	Cooling	W
	Heating	W
		TBA
Current Input	Cooling	A
	Heating	A
		TBA
Dimensions		
Net Dimensions (W x H x D)	mm	
	1,055 x 299 x 215	
Net Weight	kg	
	12.2	
Refrigerant		
Piping Connections	Liquid Pipe	ø, inch
	Gas Pipe	ø, inch
		1/4
		5/8
Piping Connections	Drain Pipe	ø, mm
		ID 16
Functions		
Airflow	Wind-Free™ Cooling	
	Air Direction Control (Up/Down)	Auto
	Air Direction Control (Left/Right)	Manual
	Auto Fan Speed	●
Air Purification	Tri-Care Filter	●
	Easy Filter Plus	●
	Auto Clean (Self-Cleaning)	●
Operating Mode	AI Auto Comfort with Wi-Fi & MDS (direct/indirect)	
	AI Auto Comfort with Wi-Fi	●
	Auto Mode (without Wi-Fi)	
	Fast Cooling	●
	Good Sleep	●
	Eco	●
	Dehumidification	●
	Fan	●
	Quiet	●
Other Functions	Samsung SmartThings	●
	MDS (Motion Detect Sensor)	
	Indoor Temperature Display	88 Display
	Display On/Off	●
	Beep On/Off	●
	Auto Changeover	●
	Auto Restart	●

Accessory



Wireless Remote Controller (included)

Dimensional drawings

Cebu

AR07/09/12TXFYAWKNEU

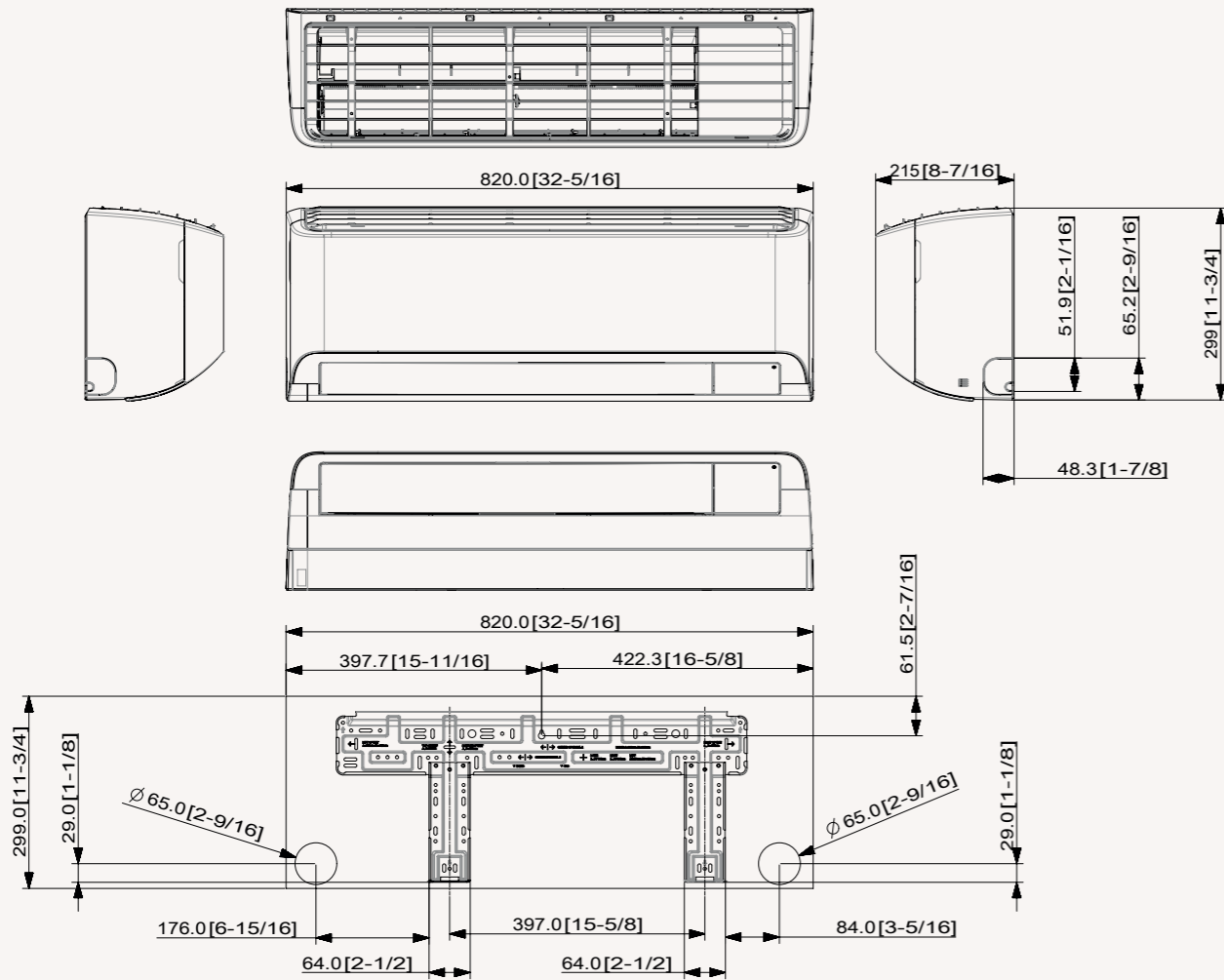

AR18/24TXFYAWKNEU

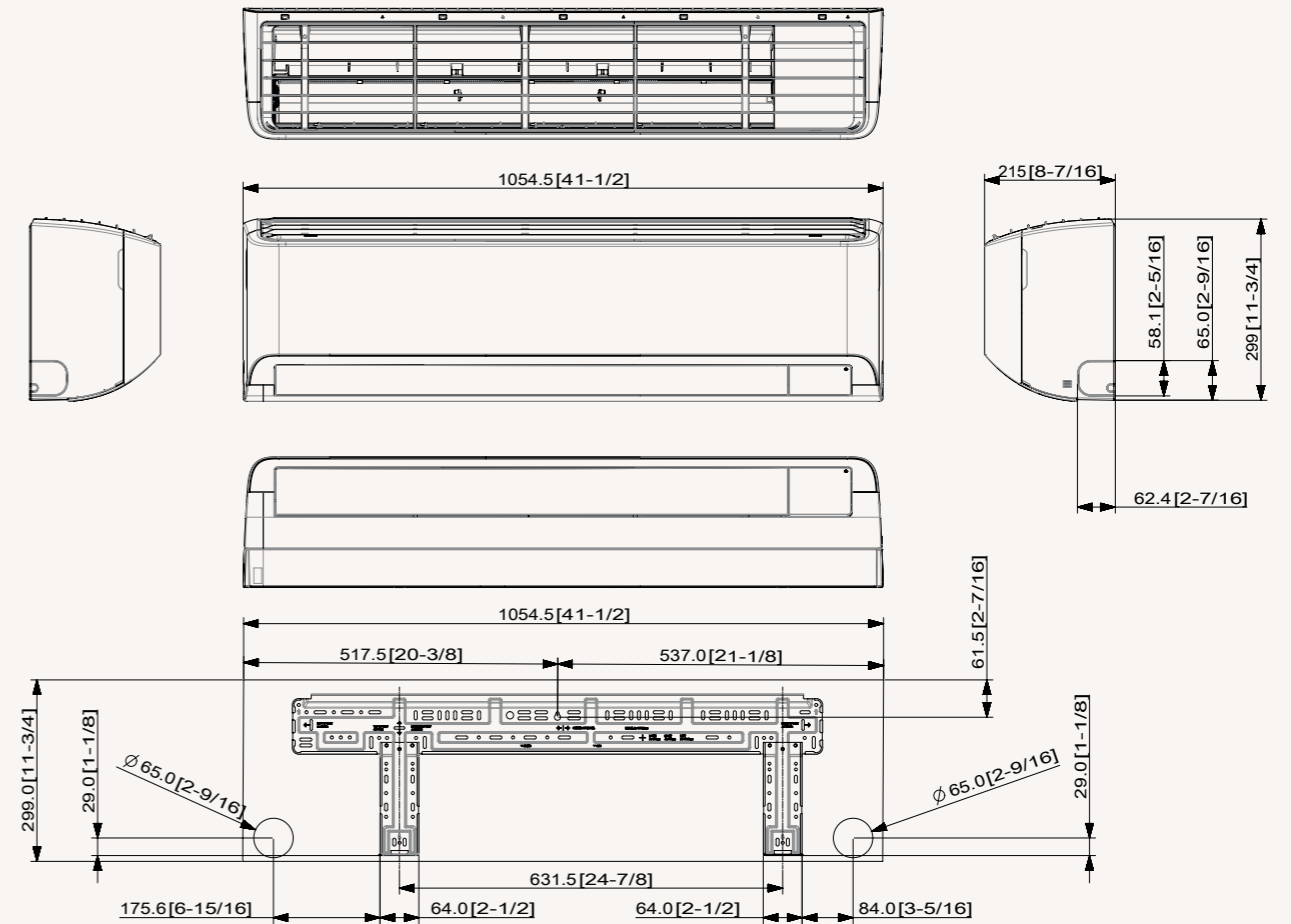

Specifications

Luzon **R32**

- Easy Filter Plus with filter cleaning indicator.
- Eco Mode and Quiet Mode.



Indoor Unit		AR07TXHZAWKNEU	AR09TXHZAWKNEU	AR12TXHZAWKNEU	AR18TXHZAWKNEU	
Capacity						
Capacity	Cooling	kW	2.0	2.5	3.5	5.0
	Heating @ +7 °C	kW	2.2	3.2	3.5	6.0
Performance						
Moisture Removal		l/h	-	1.0	1.5	2.0
Airflow Rate		m ³ /min	9.9	10.5	10.9	16.5
Sound Power	Cooling	dB(A)	54	54	56	58
	Heating	dB(A)	54	54	56	58
Sound Pressure	H/L	dB(A)	36/19	37/19	38/19	41/25
Electrical Data						
Power Source		Φ, V, Hz	1Φ, 220-240 V, 50 Hz	1Φ, 220-240 V, 50 Hz	1Φ, 220-240 V, 50 Hz	1Φ, 220-240 V, 50 Hz
Power Consumption	Cooling	W	30	30	30	TBA
	Heating	W	30	30	30	TBA
Current Input	Cooling	A	0.3	0.3	0.3	TBA
	Heating	A	0.3	0.3	0.3	TBA
Dimensions						
Net Dimensions (W x H x D)		mm	820 x 299 x 215	820 x 299 x 215	820 x 299 x 215	1,055 x 299 x 215
Net Weight		kg	8.9	8.9	8.9	12.2
Refrigerant						
Piping Connections	Liquid Pipe	ø, inch	1/4	1/4	1/4	1/4
	Gas Pipe	ø, inch	3/8	3/8	3/8	1/2
Piping Connections	Drain Pipe	ø, mm	ID 16	ID 16	ID 16	ID 16
Functions						
Airflow	Wind-Free™ Cooling					
	Air Direction Control (Up/Down)		Auto	Auto	Auto	Auto
	Air Direction Control (Left/Right)		Manual	Manual	Manual	Manual
	Auto Fan Speed		●	●	●	●
Air Purification	Tri-Care Filter		●	●	●	●
	Easy Filter Plus		●	●	●	●
	Auto Clean (Self-Cleaning)		●	●	●	●
Operating Mode	AI Auto Comfort with Wi-Fi & MDS (direct/indirect)					
	AI Auto Comfort with Wi-Fi		●	●	●	●
	Auto Mode (without Wi-Fi)		●	●	●	●
	Fast Cooling		●	●	●	●
	Good Sleep		●	●	●	●
	Eco		●	●	●	●
	Dehumidification		●	●	●	●
	Fan		●	●	●	●
	Quiet		●	●	●	●
Other Functions	Samsung SmartThings					
	MDS (Motion Detect Sensor)					
	Indoor Temperature Display	88 Display	●	●	●	●
	Display On/Off		●	●	●	●
	Beep On/Off		●	●	●	●
	Auto Changeover		●	●	●	●
Auto Restart		●	●	●	●	

Indoor Unit		AR24TXHZAWKNEU	
Capacity			
Capacity	Cooling	kW	6.5
	Heating @ +7 °C	kW	7.4
Performance			
Moisture Removal		l/h	2.5
Airflow Rate		m ³ /min	18.4
Sound Power	Cooling	dB(A)	62
	Heating	dB(A)	62
Sound Pressure	H/L	dB(A)	45/26
Electrical Data			
Power Source		Φ, V, Hz	1Φ, 220-240 V, 50 Hz
Power Consumption	Cooling	W	TBA
	Heating	W	TBA
Current Input	Cooling	A	TBA
	Heating	A	TBA
Dimensions			
Net Dimensions (W x H x D)		mm	1,055 x 299 x 215
Net Weight		kg	12.2
Refrigerant			
Piping Connections	Liquid Pipe	ø, inch	1/4
	Gas Pipe	ø, inch	5/8
Piping Connections	Drain Pipe	ø, mm	ID 16
Functions			
Airflow	Wind-Free™ Cooling		
	Air Direction Control (Up/Down)		Auto
	Air Direction Control (Left/Right)		Manual
	Auto Fan Speed		●
Air Purification	Tri-Care Filter		●
	Easy Filter Plus		●
	Auto Clean (Self-Cleaning)		●
Operating Mode	AI Auto Comfort with Wi-Fi & MDS (direct/indirect)		
	AI Auto Comfort with Wi-Fi		●
	Auto Mode (without Wi-Fi)		●
	Fast Cooling		●
	Good Sleep		●
	Eco		●
	Dehumidification		●
	Fan		●
	Quiet		●
Other Functions	Samsung SmartThings		
	MDS (Motion Detect Sensor)		
	Indoor Temperature Display	88 Display	●
	Display On/Off		●
	Beep On/Off		●
	Auto Changeover		●
Auto Restart		●	

Accessory



Wireless Remote Controller (included)

Dimensional drawings

Luzon

AR07/09/12TXHZAWKNEU

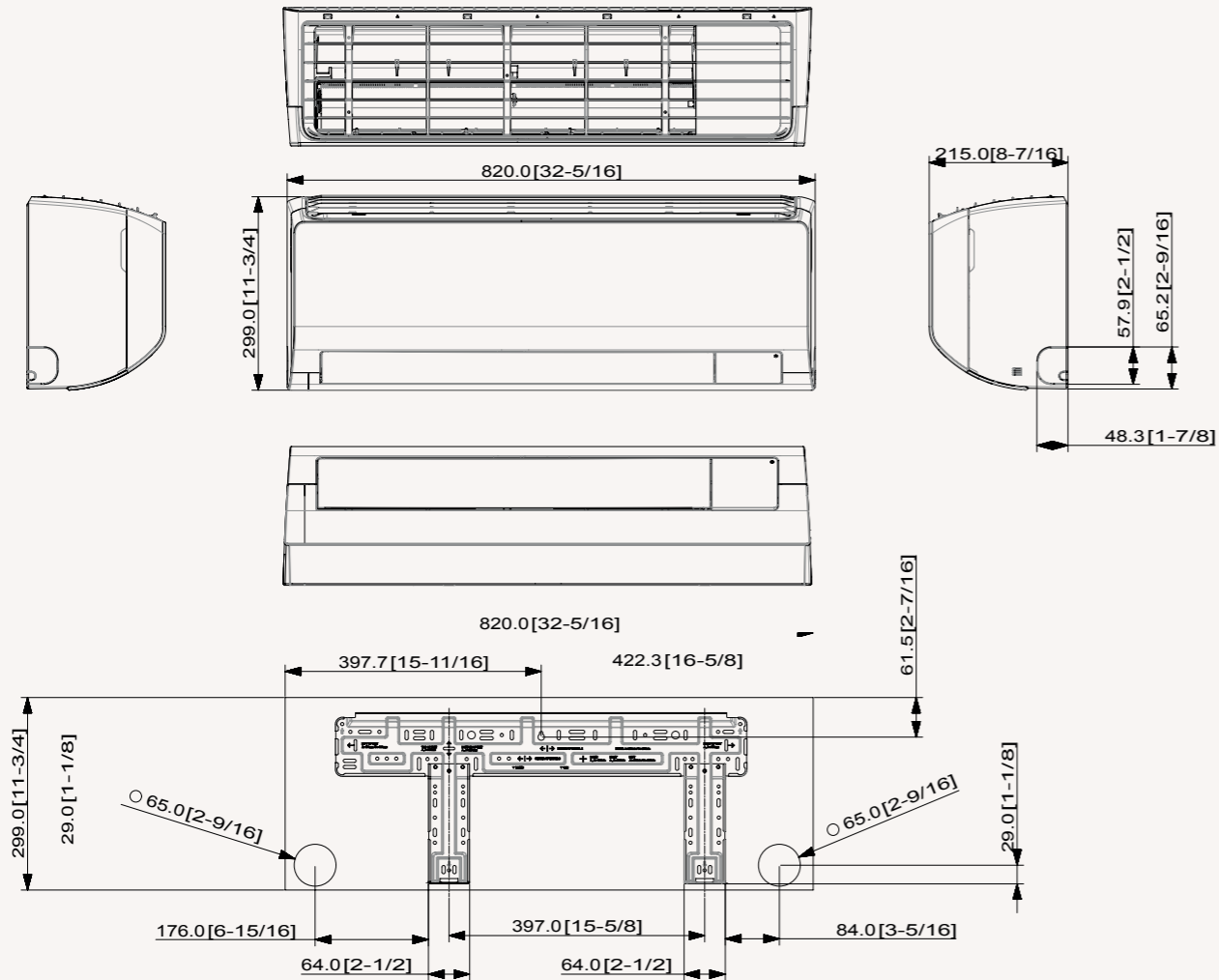

AR18/24TXHZAWKNEU

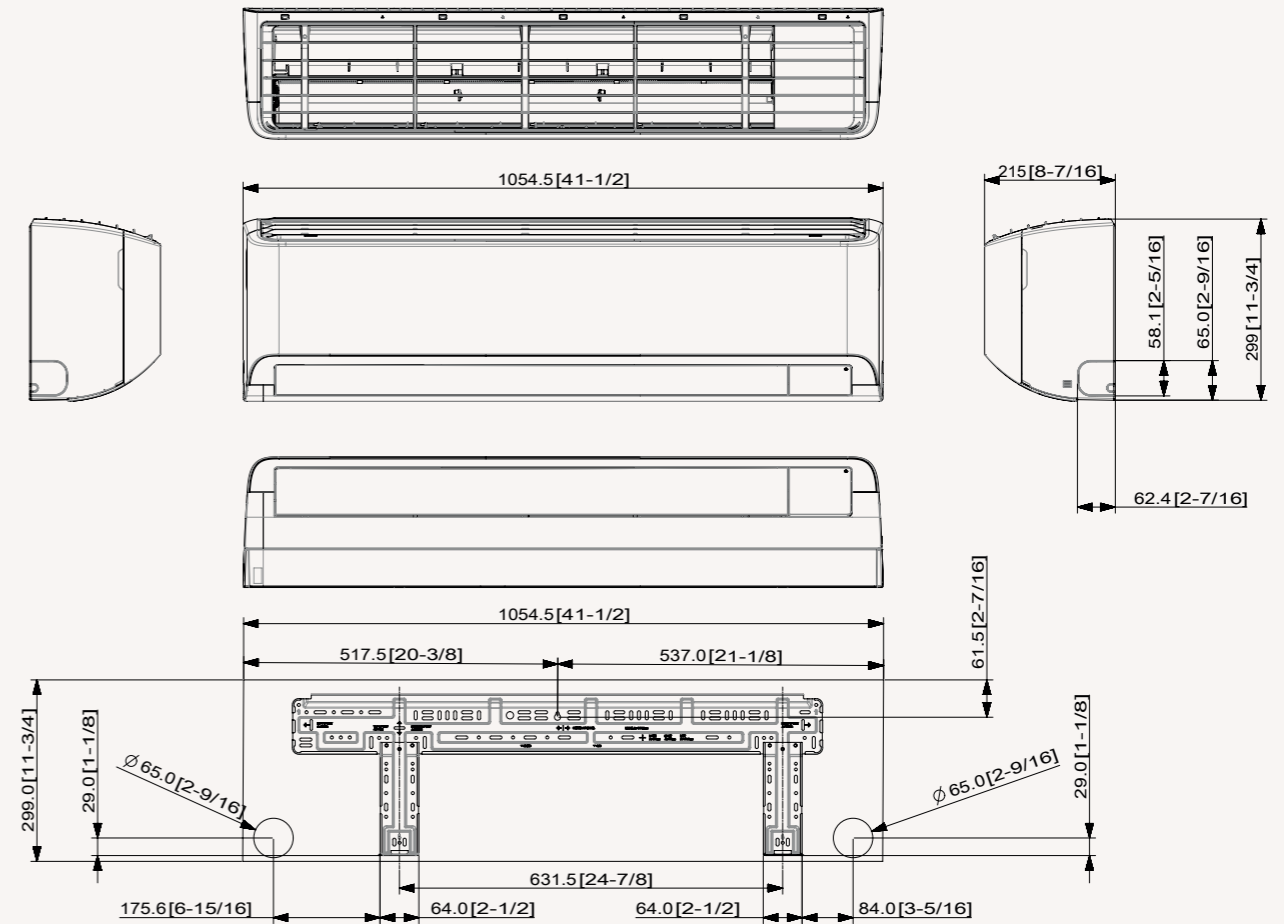

Specifications

Wind-Free™ Mini 4-Way Cassette

- 2-Step Cooling: Fast Cooling & Wind-Free™ Cooling.
- Four-way air supply via independently adjustable blades.
- Blade angle between 32° and 75°; blade width 66 mm.
- Built-in humidity sensor.
- Built-in condensation drain pump (750 mmH₂O).



Indoor Unit			AJ016TNNDKG/EU	AJ020TNNDKG/EU	AJ026TNNDKG/EU	AJ035TNNDKG/EU	AJ052TNNDKG/EU
Capacity							
	Cooling	kW	1.6	2.0	2.6	3.5	5.2
	Heating @ +7 °C	kW	2.0	2.2	2.9	3.8	5.6
Performance							
Airflow Rate		m ³ /min	9.0/8.2/6.9	9.0/8.2/6.9	9.0/8.2/6.9	10.5/9.0/7.4	10.5/9.0/7.4
Sound Power	Cooling	dB(A)	49	49	49	53	55
Sound Pressure	H/M/L	dB(A)	33/29/24	33/29/24	33/29/24	35/31/27	39/36/32
Electrical Data							
Power Source		Φ, #, V, Hz	1Φ, 2, 220-240 V, 50 Hz	1Φ, 2, 220-240 V, 50 Hz	1Φ, 2, 220-240 V, 50 Hz	1Φ, 2, 220-240 V, 50 Hz	1Φ, 2, 220-240 V, 50 Hz
Power Consumption	Cooling	W	19	19	19	22	28
	Heating	W	19	19	19	22	28
Current Input	Cooling	A	0.51	0.51	0.51	0.52	0.53
	Heating	A	0.51	0.51	0.51	0.52	0.53
Dimensions							
Net Dimensions (W x H x D)		mm	575 x 250 x 575	575 x 250 x 575	575 x 250 x 575	575 x 250 x 575	575 x 250 x 575
Net Weight		kg	11.5	11.5	11.5	11.5	11.8
Refrigerant							
Piping Connections	Liquid Pipe	ø, inch	1/4	1/4	1/4	1/4	1/4
	Gas Pipe	ø, inch	3/8	3/8	3/8	3/8	1/2
Piping Connections	Drain Pipe	ø, mm	VP25 (OD 32, ID 25)	VP25 (OD 32, ID 25)	VP25 (OD 32, ID 25)	VP25 (OD 32, ID 25)	VP25 (OD 32, ID 25)
Others							
Panel	Model Code		PC4SUFMAN	PC4SUFMAN	PC4SUFMAN	PC4SUFMAN	PC4SUFMAN
	Net Dimensions (W x H x D)	mm	620 x 57 x 620	620 x 57 x 620	620 x 57 x 620	620 x 57 x 620	620 x 57 x 620
	Net Weight	kg	2.7	2.7	2.7	2.7	2.7
Accessories	Drain Pump		Included	Included	Included	Included	Included
	Max. Lifting Height/Displacement	mm / litres/h	750/24	750/24	750/24	750/24	750/24

Accessories



Advanced Wired Controller	Simple Type Controller	Touch Controller	Wired Remote Controller	Wi-Fi Kit	Panel (Required)
MWR-WG00JN/MWR-WG00KN	MWR-SH00N	MWR-SH11N	MWR-WE13N	MIM-H04EN	PC4SUFMAN

Dimensional drawings

Wind-Free™ Mini 4-Way Cassette

AJ016/020/026/035/052TNNDKG/EU

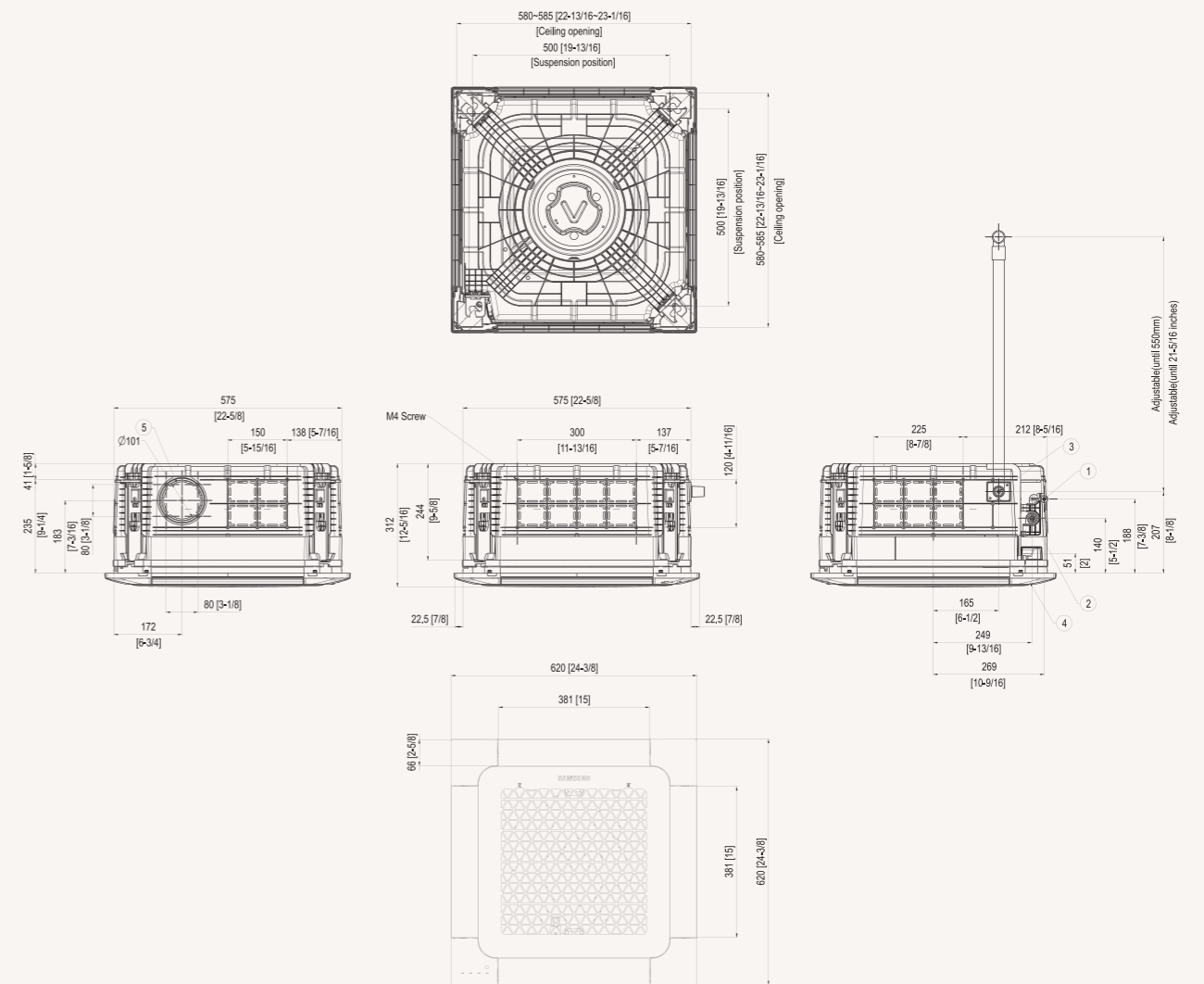

NO	Name	Description				
		4.5 kW	5.6 kW	7.1 kW	9.0 kW	5.2 kW
1	Liquid pipe connection			ø6.35 (1/4)		
2	Gas pipe connection		Φ9.52 (3/8)			ø12.70 (1/2)
3	Drain pipe connection			VP25 (OD 32, ID 25)		
4	Power supply/communication wiring conduits					
5	Fresh air intake knock-out hole			ø101 (4), use M4 Screw		

Specifications

Wind-Free™ 1-Way Cassette

- 2-Step Cooling: Fast Cooling & Wind-Free™ Cooling.
- Blade angle between 37° and 87°, blade width 100 mm.
- Built-in humidity sensor.
- Height of only 135 mm.
- Built-in condensation drain pump (750 mmH₂O).



Indoor Unit		AJ026TN1DKG/EU	AJ035TN1DKG/EU		
Capacity					
	Cooling	kW	2.6	3.5	
	Heating @ +7 °C	kW	2.9	3.8	
Performance					
	Airflow Rate	m ³ /min	6.2/5.2/4.2	7.6/6.6/5.6	
	Sound Power	Cooling	dB(A)	50	55
	Sound Pressure	H/M/L	dB(A)	32/29/26	37/33/30
Electrical Data					
	Power Source	Φ, #, V, Hz	1Φ, 2, 220-240 V, 50 Hz	1Φ, 2, 220-240 V, 50 Hz	
	Power Consumption	Cooling	W	45	50
		Heating	W	45	50
	Current Input	Cooling	A	0.23	0.25
		Heating	A	0.23	0.25
Dimensions					
	Net Dimensions (W x H x D)	mm	970 x 135 x 410	970 x 135 x 410	
	Net Weight	kg	10.0	10.0	
Refrigerant					
	Piping Connections	Liquid Pipe	ø, inch	1/4	1/4
		Gas Pipe	ø, inch	3/8	3/8
	Piping Connections	Drain Pipe	ø, mm	VP20 (OD 26, ID 20)	VP20 (OD 26, ID 20)
Others					
	Panel	Model Code	PC1NWFMAN	PC1NWFMAN	
		Net Dimensions (W x H x D)	mm	1,198 x 35 x 500	1,198 x 35 x 500
		Net Weight	kg	4.3	4.3
	Accessories	Drain Pump	Included	Included	
		Max. Lifting Height/Displacement	mm / litres/h	750/24	750/24

Accessories



Wireless Remote Controller	Advanced Wired Controller	Simple Type Controller	Touch Controller	Wired Remote Controller	Wi-Fi Kit	Panel (Required)
AR-EH03E	MWR-WG00JN/ MWR-WG00KN	MWR-SH00N	MWR-SH11N	MWR-WE13N	MIM-H04EN	PC1NWFMAN

Dimensional drawings

Wind-Free™ 1-Way Cassette

AJ026/035TN1DKG/EU

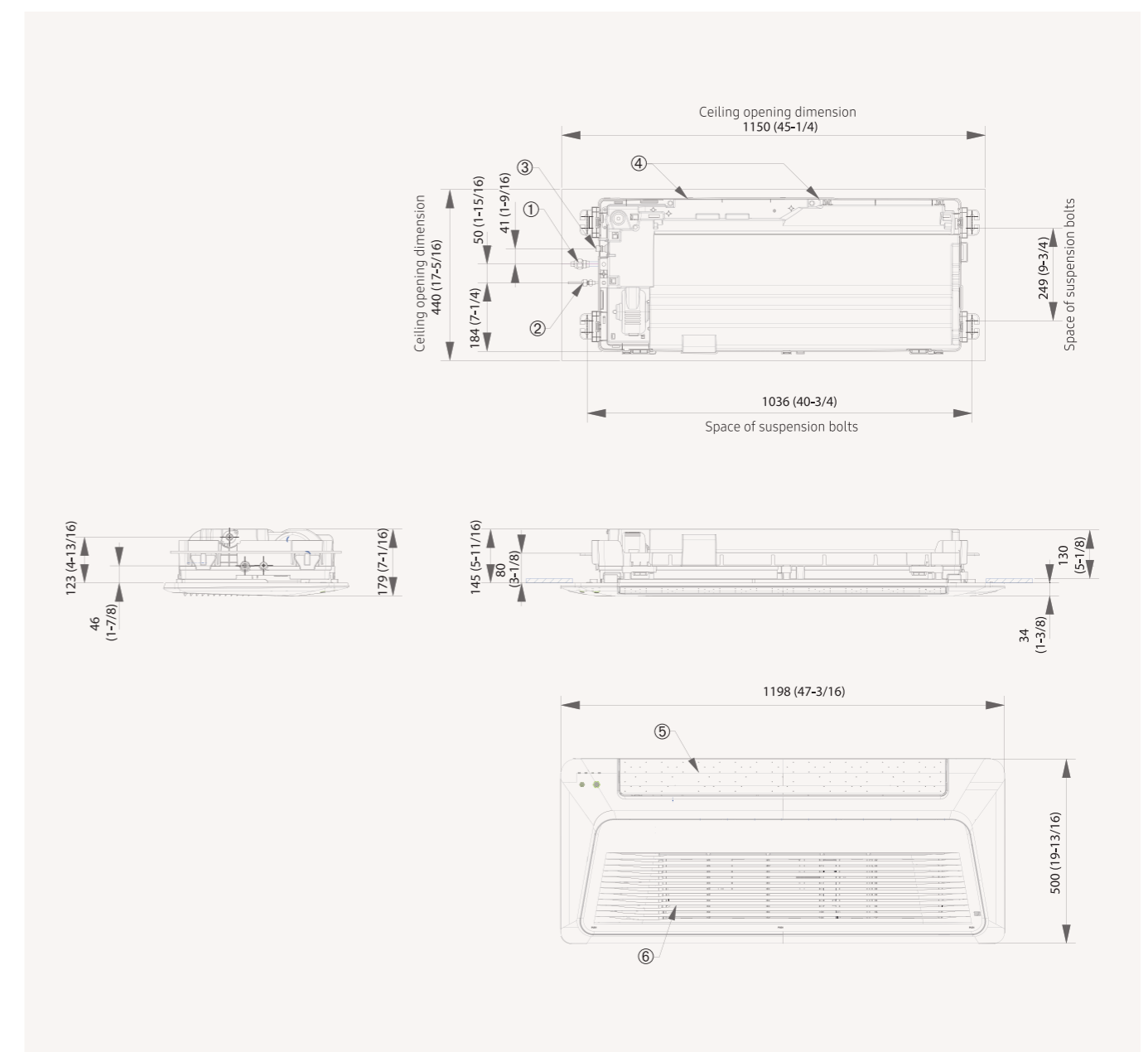

NO	Name	Description
1	Gas pipe connection	ø12.70 (1/2)
2	Liquid pipe connection	ø6.35 (1/4)
3	Drain hose connection	VP20 (OD 26, ID 20)
4	Power supply/communication wiring conduits	
5	Air outlet louvre	
6	Air inlet grille	

Specifications

MSP Duct (drain pump included)

- High efficiency microchannel heat exchanger.
- Built-in electronic expansion valve (EEV) for refrigerant flow control (2000-step).
- Auto Restart function.
- Condensation drain pump.
- Long-life HD 40 permanent filter is included.
- Auto ESP function.
- SPI Ioniser.



Indoor Unit		AJ052TNMDEG/EU	
Capacity			
Cooling	kW	5.2	
Heating up to +7 °C	kW	5.6	
Performance			
Airflow Rate	m ³ /min	16.3/15.0/13.5	
Sound Power	Cooling dB(A)	59	
Sound Pressure	H/M/L dB(A)	42/41/39	
Electrical Data			
Power Source	Φ, #, V, Hz	1Φ, 2, 220-240 V, 50 Hz	
Power Consumption	Cooling W	170	
	Heating W	170	
Current Input	Cooling A	1.04	
	Heating A	1.04	
Dimensions			
Net Dimensions (W x H x D)	mm	900 x 260 x 480	
Net Weight	kg	28.3	
Refrigerant			
Piping Connections	Liquid Pipe	ø, inch	1/4
	Gas Pipe	ø, inch	1/2
Piping Connections	Drain Pipe	ø, mm	VP25 (OD 32, ID 25)
Others			
Accessories	Drain Pump	MDP-M075SGU3	
	Max. Lifting Height/Displacement	mm / litres/h	750/24
	Air Filter	Removable/Washable	

Accessories



Advanced Wired Controller	Simple Type Controller	Touch Controller	Wired Remote Controller	Wi-Fi Kit
MWR-WG00JN/MWR-WG00KN	MWR-SH00N	MWR-SH11N	MWR-WE13N	MIM-H04EN

Dimensional drawings

MSP Duct (drain pump included)

AJ052TNMDEG**

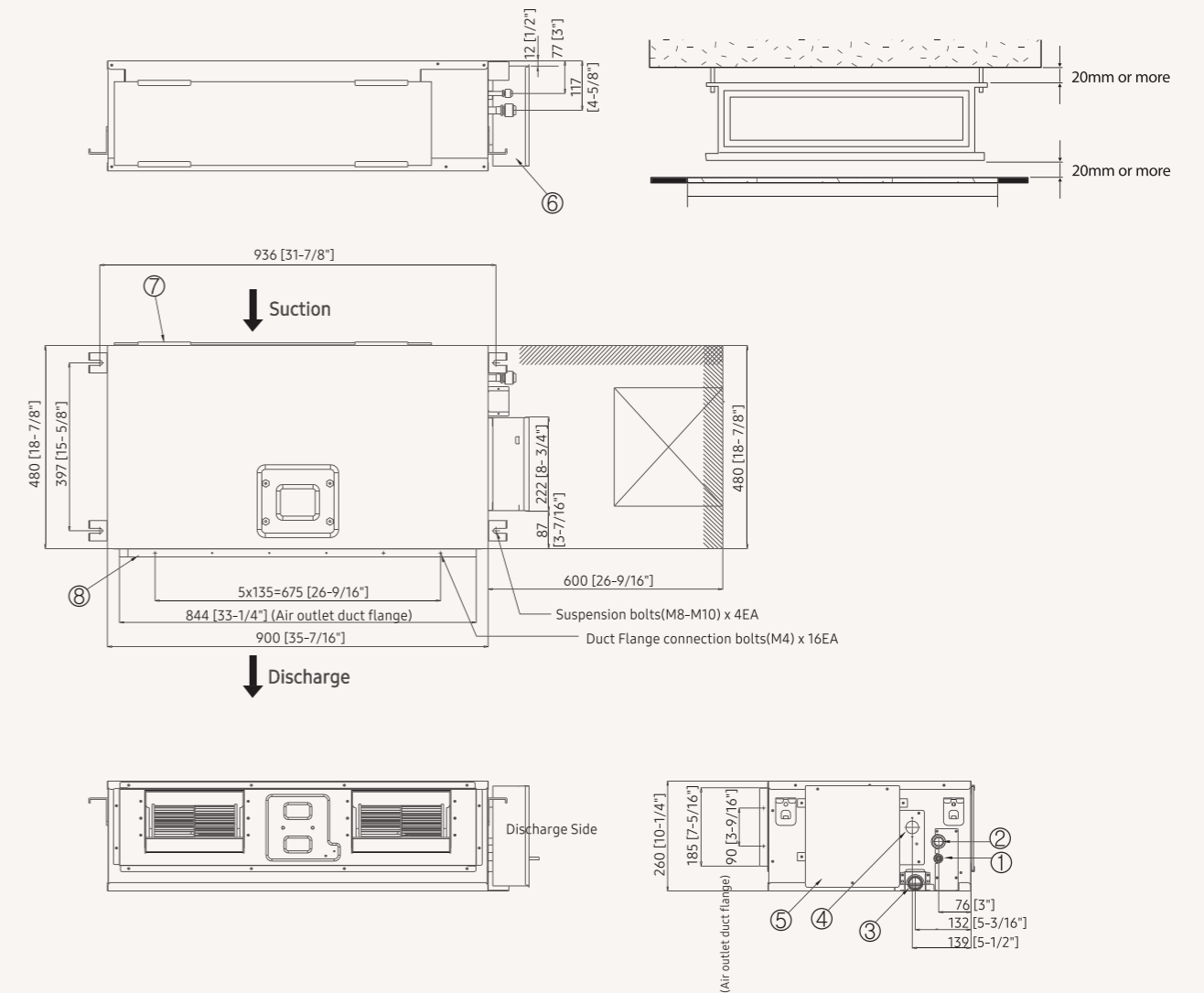

NO	Name	Description
1	Liquid pipe connection	ø6.35 (1/4)
2	Gas pipe connection	ø12.70 (1/2)
3	Drain pipe connection	VP25 (OD 32, ID 25)
4	Knock-out hole for drain pump	Option kit
5	Control unit	
6	Power supply/communication wiring conduits	
7	Return air side	
8	Air outlet duct flange	

Specifications

LSP Duct (drain pump included)

- High efficiency microchannel heat exchanger.
- Built-in electronic expansion valve (EEV) for refrigerant flow control (2000-step).
- Auto Restart function.
- Condensation drain pump.
- Long-life HD 40 permanent filter is included.
- Auto ESP function.
- SPI Ioniser.



Indoor Unit			AJ026TNLDEG/EU	AJ035TNLDEG/EU
Capacity				
	Cooling	kW	2.6	3.5
	Heating up to +7 °C	kW	2.9	3.8
Performance				
	Airflow Rate	m ³ /min	8.6/7.6/6.6	9.8/8.8/7.8
	Sound Power	Cooling dB(A)	53	53
	Sound Pressure	H/M/L dB(A)	30/28/25	32/30/27
Electrical Data				
	Power Source	Φ, #, V, Hz	1Φ, 2, 220-240 V, 50 Hz	1Φ, 2, 220-240 V, 50 Hz
	Power Consumption	Cooling W	80	80
		Heating W	80	80
	Current Input	Cooling A	0.4	0.4
		Heating A	0.4	0.4
Dimensions				
	Net Dimensions (W x H x D)	mm	900 x 199 x 600	900 x 199 x 600
	Net Weight	kg	23.3	23.3
Refrigerant				
	Piping Connections	Liquid Pipe ø, inch	1/4	1/4
		Gas Pipe ø, inch	3/8	3/8
	Piping Connections	Drain Pipe ø, mm	VP25 (OD 32, ID 25)	VP25 (OD 32, ID 25)
Others				
	Accessories	Drain Pump	MDP-E075SEE3	MDP-E075SEE3
		Max. Lifting Height/ Displacement	mm / litres/h	750/24
		Air Filter	Removable/Washable	Removable/Washable

Accessories



Advanced Wired Controller	Simple Type Controller	Touch Controller	Wired Remote Controller	Wi-Fi Kit
MWR-WG00JN/MWR-WG00KN	MWR-SH00N	MWR-SH11N	MWR-WE13N	MIM-H04EN

Dimensional drawings

LSP Duct

AJ***TNLDEG/EU

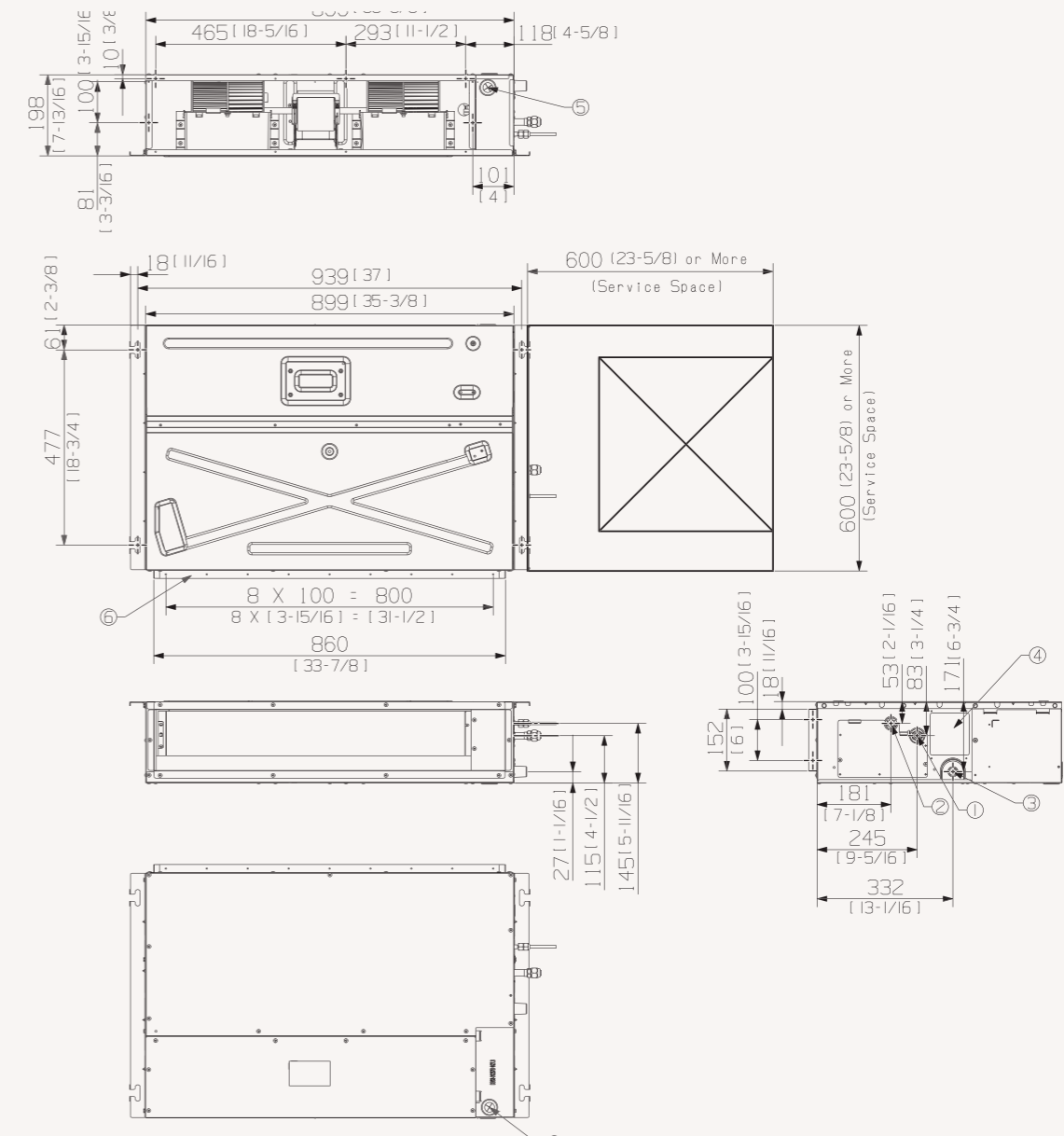

NO	Name	Description
1	Gas pipe connection	ø9.52 (3/8)
2	Liquid pipe connection	ø6.35 (1/4)
3	Drain pipe connection	VP25 (OD 32, ID 25)
4	Knock-out hole for drain pump	Option kit
5	Power supply/communication wiring conduits	
6	Air outlet duct flange	

Specifications

Console

- SPI Ioniser (included).
- Slim design: only 100 mm in width.
- Built-in electronic expansion valve (EEV) for refrigerant flow control (2000-step).
- Two separate air outlets, upper (cooling) and bottom (heating) to avoid stratification.
- Long-life washable permanent filter.
- Auto Restart function.



Indoor Unit		AJ026TNJDKG/EU	AJ035TNJDKG/EU	AJ052TNJDKG/EU	
Capacity					
	Cooling	kW	2.6	3.5	5.2
	Heating up to +7 °C	kW	2.9	3.8	5.6
Performance					
	Airflow Rate	m ³ /min	9.0/7.8/6.7	10.5/9.3/8.2	11.2/9.9/8.6
	Sound Power	Cooling dB(A)	53	57	60
	Sound Pressure	H/M/L dB(A)	36/31/23	38/35/24	43/39/32
Electrical Data					
	Power Source	Φ, #, V, Hz	1Φ, 2, 220-240 V, 50 Hz	1Φ, 2, 220-240 V, 50 Hz	1Φ, 2, 220-240 V, 50 Hz
	Power Consumption	Cooling W	30	35	50
		Heating W	30	35	50
	Current Input	Cooling A	0.25	0.29	0.29
		Heating A	0.25	0.29	0.29
Dimensions					
	Net Dimensions (W x H x D)	mm	720 x 199 x 620	720 x 199 x 620	720 x 199 x 620
	Net Weight	kg	15.7	15.7	15.7
Refrigerant					
	Piping Connections	Liquid Pipe ø, inch	1/4	1/4	1/4
		Gas Pipe ø, inch	3/8	3/8	1/2
	Piping Connections	Drain Pipe ø, mm	VP25 (OD 32, ID 25)	VP25 (OD 32, ID 25)	VP25 (OD 32, ID 25)

Accessories



Advanced Wired Controller	Simple Type Controller	Touch Controller	Wired Remote Controller	Wi-Fi Kit
MWR-WG00JN/MWR-WG00KN	MWR-SH00N	MWR-SH11N	MWR-WE13N	MIM-H04EN

Dimensional drawings

Console

AJ***TNJDKG/EU

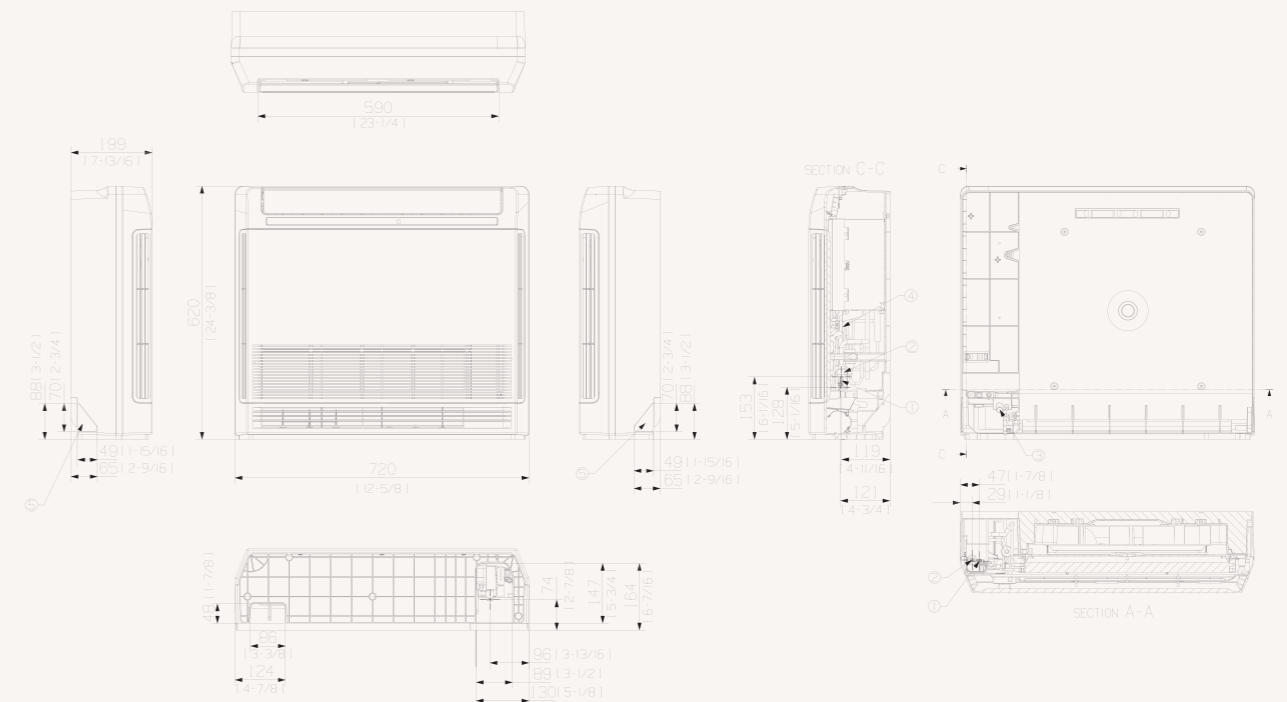

NO	Name	Description
		AJ026RBJDEG/EU MH026FJEA
		AJ035/052RBJDEG/EU MH035/052FJEA
1	Liquid pipe connection	ø6.35 (1/4)
2	Gas pipe connection	ø9.52 (3/8)
3	Drain pipe connection	ID18 [11/16] Hose
4	Power supply/communication wiring conduits	
5	Knockout hole for drain hose	

Combination guide

4-1. AJ040TXJ2KG/EU

Cooling

Outdoor Unit	A	B	Cooling Capacity		Capacity			Power Consumption			Current			Effic. NOM. Cooling at 35 °C/27 °C EER	Seasonal Efficiency (According to EN14825) Class	SEER	Qce kWh
			W		W			W			A						
			A	B	MIN	STD	MAX	MIN	STD	MAX	MIN	STD	MAX				
AJ040TXJ2KG 2 Unit	7	7	2,000	2,000	1,300	4,000	4,700	300	900	1,250	1.7	4.1	5.7	4.44	A+++	8.54	164
	7	9	1,780	2,220	1,300	4,000	4,700	350	920	1,270	1.9	4.2	5.8	4.35	A+++	8.51	165
	7	12	1,450	2,550	1,300	4,000	4,700	350	930	1,280	1.9	4.3	5.9	4.30	A+++	8.51	165
	9	9	2,000	2,000	1,300	4,000	4,700	350	940	1,290	1.9	4.3	5.9	4.26	A+++	8.51	165
	9	12	1,670	2,330	1,300	4,000	4,700	350	950	1,300	1.9	4.3	5.9	4.21	A+++	8.51	165

Heating

Outdoor Unit	A	B	Heating Capacity		Capacity			Power Consumption			Current			Effic. NOM. Heating at 7 °C/20 °C COP ¹	Seasonal Efficiency (According to EN14825) Class	SCOP	P design kW	Qhe kWh
			W		W			W			A							
			A	B	MIN	STD	MAX	MIN	STD	MAX	MIN	STD	MAX					
AJ040TXJ2KG 2 Unit	7	7	2,100	2,100	1,000	4,200	4,700	280	900	1,180	1.4	4.1	5.4	4.67	A++	4.64	3.05	922
	7	9	1,840	2,360	1,000	4,200	4,700	280	920	1,190	1.4	4.2	5.4	4.57	A++	4.61	3.05	927
	7	12	1,550	2,650	1,000	4,200	4,700	280	930	1,200	1.4	4.3	5.5	4.52	A++	4.61	3.05	927
	9	9	2,100	2,100	1,000	4,200	4,700	280	940	1,210	1.4	4.3	5.5	4.47	A++	4.61	3.05	927
	9	12	1,800	2,400	1,000	4,200	4,700	280	950	1,220	1.4	4.3	5.6	4.42	A++	4.61	3.05	927

- EER and COP declared only for the purpose of tax deductions in force at the time of the creation of this catalogue.
- The above is the value for connecting with the following indoor units. Wind-Free™ Elite: AR07TXCAAWK, AR09TXCAAWK, AR12TXCAAWK.
- You cannot connect a single unit.
- Power consumption includes indoor unit power.

4-2. AJ050TXJ2KG/EU

Cooling

Outdoor Unit	A	B	Cooling Capacity		Capacity			Power Consumption			Current			Effic. NOM. Cooling at 35 °C/27 °C EER	Seasonal Efficiency (According to EN14825) Class	SEER	Qce kWh
			W		W			W			A						
			A	B	MIN	STD	MAX	MIN	STD	MAX	MIN	STD	MAX				
AJ050TXJ2KG 2 Unit	7	7	2,000	2,000	1,300	4,000	4,700	350	980	1,290	1.9	4.5	5.9	4.08	A+++	8.51	165
	7	9	2,040	2,560	1,300	4,600	5,200	350	1,120	1,520	1.9	5.1	7.0	4.11	A+++	8.51	189
	7	12	1,820	3,180	1,400	5,000	5,500	350	1,230	1,510	1.9	5.6	6.9	4.07	A+++	8.51	206
	7	18	1,430	3,570	1,400	5,000	5,500	350	1,200	1,510	1.9	5.5	6.9	4.15	A+++	8.51	206
	9	9	2,500	2,500	1,400	5,000	5,500	350	1,220	1,500	1.9	5.6	6.9	4.10	A+++	8.54	205
	9	12	2,080	2,920	1,400	5,000	5,500	350	1,230	1,510	1.9	5.6	6.9	4.07	A+++	8.51	206
	9	18	1,670	3,330	1,400	5,000	5,500	350	1,230	1,510	1.9	5.5	6.9	4.15	A+++	8.51	206
	12	12	2,500	2,500	1,400	5,000	5,500	350	1,240	1,520	1.9	5.7	7.0	4.03	A+++	8.51	206
	12	18	2,060	2,940	1,400	5,000	5,500	350	1,240	1,520	1.9	5.6	7.0	4.15	A+++	8.51	206

Heating

Outdoor Unit	A	B	Heating Capacity		Capacity			Power Consumption			Current			Effic. NOM. Heating at 7 °C/20 °C COP ¹	Seasonal Efficiency (According to EN14825) Class	SCOP	P design kW	Qhe kWh
			W		W			W			A							
			A	B	MIN	STD	MAX	MIN	STD	MAX	MIN	STD	MAX					
AJ040TXJ2KG 2 Unit	7	7	2,200	2,200	1,400	4,400	4,700	280	1,010	1,210	1.4	4.6	5.5	4.36	A++	4.61	3.05	927
	7	9	2,230	2,870	1,400	5,100	5,460	280	1,310	1,610	1.4	6	7.4	3.89	A++	4.61	4.21	1,277
	7	12	2,060	3,540	1,400	5,600	6,300	280	1,290	1,710	1.4	5.9	7.8	4.34	A++	4.61	4.21	1,277
	7	18	1,530	4,170	1,400	5,600	6,300	280	1,270	1,70	1.4	5.7	7.8	4.41	A++	4.61	4.07	1,237
	9	9	2,800	2,800	1,400	5,600	6,300	280	1,280	1,700	1.4	5.9	7.8	4.38	A++	4.64	4.21	1,270
	9	12	2,400	3,200	1,400	5,600	6,300	280	1,290	1,710	1.4	5.9	7.8	4.34	A++	4.61	4.21	1,277
	9	18	2,020	3,680	1,400	5,600	6,300	280	1,270	1,70	1.4	5.7	7.8	4.41	A++	4.61	4.07	1,237
	12	12	2,800	2,800	1,400	5,600	6,300	280	1,300	1,720	1.4	5.9	7.9	4.31	A++	4.61	4.21	1,277
	12	18	2,280	3,420	1,400	5,600	6,300	280	1,280	1,720	1.4	5.8	7.9	4.38	A++	4.61	4.07	1,237

- EER and COP declared only for the purpose of tax deductions in force at the time of the creation of this catalogue.
- The above is the value for connecting with the following indoor units. Wind Free™ Elite: AR07TXCAAWK, AR09TXCAAWK, AR12TXCAAWK.
- You cannot connect a single unit.
- Power consumption includes indoor unit power.

Combination guide

4-3. AJ052TXJ3KG/EU

Cooling

Outdoor Unit	A	B	C	Cooling Capacity			Capacity			Power Consumption			Current			Effic. NOM. Cooling at 35 °C/27 °C EER	Seasonal Efficiency (According to EN14825) Class	SEER	Qce kWh	
				W			W			W			A							
				A	B	C	MIN	STD	MAX	MIN	STD	MAX	MIN	STD	MAX					MIN
AJ052TXJ3KG	2 Unit	7	7		2,000	2,000		1,100	4,000	4,800	320	1,020	1,630	2	4.5	7.5	3.92	A++	8.08	173
		7	9		2,040	2,560		1,100	4,600	5,520	320	1,170	1,850	2	5.2	8.5	3.93	A++	7.73	208
		7	12		1,820	3,180		1,100	5,000	6,290	320	1,260	2,000	2	5.6	9.2	3.97	A++	8.15	215
		7	18		1,490	3,710		1,200	5,200	6,600	320	1,300	2,040	2	5.7	9.3	4.00	A++	7.85	232
		9	9		2,500	2,500		1,100	5,000	5,800	320	1,160	1,980	2	5.1	9.1	4.30	A+++	8.51	206
		9	12		2,080	2,920		1,100	5,000	6,400	320	1,250	2,020	2	5.5	9.2	4.00	A++	8.16	214
	9	18		1,730	3,470		1,200	5,200	6,800	320	1,300	2,070	2	5.7	9.5	4.00	A++	7.85	232	
	12	12		2,600	2,600		1,100	5,200	6,560	320	1,300	2,040	2	5.7	9.3	4.00	A++	8.16	214	
	3 Unit	7	7	7	1,730	1,730	1,740	1,450	5,200	6,380	330	1,280	2,020	2	5.7	9.2	4.06	A++	7.68	237
		7	7	9	1,600	1,600	2,000	1,450	5,200	6,490	330	1,290	2,040	2	5.7	9.3	4.03	A++	7.67	237
		7	7	12	1,390	1,390	2,420	1,450	5,200	6,800	330	1,270	2,070	2	5.6	9.5	4.09	A++	7.69	237
		7	9	9	1,480	1,860	1,860	1,450	5,200	6,600	330	1,260	2,040	2	5.6	9.3	4.13	A++	7.70	236
7		9	12	1,300	1,630	2,270	1,450	5,200	6,800	330	1,270	2,070	2	5.6	9.5	4.11	A++	7.69	237	
9		9	9	1,730	1,730	1,740	1,450	5,200	6,800	330	1,250	2,070	2	5.5	9.5	4.16	A++	7.70	236	
9	9	12	1,530	1,530	2,140	1,450	5,200	6,800	330	1,250	2,070	2	5.5	9.5	4.16	A++	8.08	225		

Heating

Outdoor Unit	A	B	C	Heating Capacity			Capacity			Power Consumption			Current			Effic. NOM. Heating at 7 °C/20 °C EER	Seasonal Efficiency (According to EN14825) Class	SCOP	P design kWh	Qhe kWh	
				W			W			W			A								
				A	B	C	MIN	STD	MAX	MIN	STD	MAX	MIN	STD	MAX						MIN
AJ052TXJ3KG	2 Unit	7	7		2,200	2,200		950	4,400	5,060	280	1,150	1,510	1.7	5.4	6.9	3.83	A+	4.40	3.05	970
		7	9		2,040	3,060		950	5,100	5,870	280	1,320	1,830	1.7	6.1	8.4	3.86	A+	4.35	4.21	1,352
		7	12		1,990	3,610		950	5,600	6,440	280	1,450	1,860	1.7	6.7	8.5	3.86	A+	4.34	4.60	1,484
		7	18		1,610	4,390		950	6,000	6,900	280	1,570	1,860	1.7	7.2	8.5	3.82	A+	4.27	4.28	1,401
		9	9		2,900	2,900		950	5,800	6,300	280	1,510	1,910	1.7	6.9	8.7	3.84	A++	4.60	4.60	1,400
		9	12		2,620	3,180		950	5,800	6,300	280	1,510	1,910	1.7	6.9	8.7	3.84	A+	4.34	4.60	1,484
	9	18		2,240	4,060		950	6,300	7,300	280	1,640	1,830	1.7	7.5	8.4	3.84	A+	4.27	4.28	1,401	
	12	12		2,950	2,950		950	5,900	6,880	280	1,530	1,860	1.7	7.0	8.5	3.86	A+	4.34	4.60	1,484	
	3 Unit	7	7	7	1,930	1,930	1,940	1,000	5,800	6,760	280	1,500	1,840	1.7	6.9	8.4	3.87	A+	4.30	4.60	1,497
		7	7	9	1,690	1,690	2,520	1,000	5,900	6,840	280	1,550	1,840	1.7	7.1	8.4	3.81	A+	4.30	4.60	1,497
		7	7	12	1,650	1,650	3,000	1,000	6,300	7,300	280	1,560	1,830	1.7	7.1	8.4	4.04	A+	4.30	4.60	1,497
		7	9	9	1,500	2,250	2,250	1,000	6,000	6,920	280	1,500	1,840	1.7	6.9	8.4	4.00	A+	4.30	4.60	1,497
7		9	12	1,460	2,190	2,650	1,000	6,300	7,300	280	1,530	1,830	1.7	7.0	8.4	4.12	A+	4.30	4.60	1,497	
9		9	9	2,100	2,100	2,100	1,000	6,300	7,300	280	1,320	1,830	1.7	6.1	8.4	4.77	A+	4.30	4.60	1,497	
9	9	12	1,850	1,850	2,600	1,000	6,300	7,300	280	1,320	1,830	1.7	6.1	8.4	4.77	A+	4.30	4.60	1,497		

- EER and COP declared only for the purpose of tax deductions in force at the time of the creation of this catalogue.
- The above is the value for connecting with the following indoor units. Wind-Free™ Elite: AR07TXCAAWK, AR09TXCAAWK, AR12TXCAAWK.
- You cannot connect a single unit.
- Power consumption includes indoor unit power.

4-4. AJ068TXJ3KG/EU

Cooling

Outdoor Unit	A	B	C	Cooling Capacity			Capacity			Power Consumption			Current			Effic. NOM. Cooling at 35 °C/27 °C EER	Seasonal Efficiency (According to EN14825) Class	SEER	Qce kWh		
				W			W			W			A								
				A	B	C	MIN	STD	MAX	MIN	STD	MAX	MIN	STD	MAX					MIN	STD
AJ068TXJ3KG	2 Unit	7	7		2,000	2,000		1,300	4,000	4,800	420	1,110	1,480	2.3	5.2	6.8	3.60	A++	7.55	185	
		7	9		2,000	2,500		1,300	4,500	5,520	420	1,270	1,680	2.3	5.9	7.7	3.54	A++	7.47	211	
		7	12		2,000	3,500		1,300	5,500	6,550	420	1,500	2,470	2.3	6.9	11.3	3.50	A++	7.14	270	
		7	18		1,860	4,640		1,300	6,500	7,740	420	1,660	2,690	2.3	7.6	12.3	3.62	A++	7.54	302	
		9	9		2,500	2,500		1,300	5,000	5,950	420	1,430	2,260	2.3	6.6	10.3	3.50	A++	7.55	232	
		9	12		2,500	3,500		1,300	6,000	7,140	420	1,650	2,670	2.3	7.5	12.2	3.64	A++	7.48	281	
		9	18		2,270	4,530		1,380	6,800	8,090	430	1,870	2,660	2.3	8.5	12.2	3.64	A++	7.57	314	
		12	12		3,250	3,250		1,300	6,500	7,740	420	1,770	2,700	2.3	8.0	12.4	3.67	A++	7.56	301	
		12	18		2,800	4,000		1,380	6,800	8,090	430	1,880	2,670	2.3	8.5	12.2	3.62	A++	7.56	315	
		18	18		3,400	3,400		1,380	6,800	8,090	430	1,850	2,660	2.3	8.4	12.2	3.68	A++	7.58	314	
		3 Unit	7	7	7	2,000	2,000	2,000	1,800	6,000	7,400	440	1,620	2,650	2.3	7.4	12.1	3.70	A++	7.62	276
			7	7	9	2,000	2,000	2,500	1,800	6,500	8,000	440	1,770	2,690	2.3	8.0	12.3	3.67	A++	7.64	298
	7		7	12	1,810	1,810	3,180	1,800	6,800	8,400	440	1,850	2,700	2.3	8.4	12.4	3.68	A++	7.67	310	
	7		7	18	1,510	1,510	3,780	1,800	6,800	8,400	440	1,800	2,690	2.3	8.1	12.3	3.78	A++	7.69	309	
	7		9	9	1,860	2,320	2,320	1,800	6,500	8,000	440	1,670	2,690	2.3	7.6	12.3	3.90	A++	7.75	293	
	7		9	12	1,700	2,130	2,970	1,800	6,800	8,400	440	1,840	2,690	2.3	8.3	12.3	3.70	A++	7.67	310	
	7		9	18	1,430	1,790	3,580	1,800	6,800	8,400	440	1,830	2,690	2.3	8.3	12.3	3.72	A++	7.68	310	
	7		12	12	1,520	2,640	2,640	1,800	6,800	8,400	440	1,830	2,700	2.3	8.3	12.4	3.72	A++	7.68	310	
	7		12	18	1,300	2,270	3,230	1,800	6,800	8,400	440	1,830	2,700	2.3	8.3	12.4	3.72	A++	7.68	310	
	9		9	9	2,260	2,270	2,270	1,800	6,800	8,400	440	1,820	2,690	2.3	8.3	12.3	3.74	A++	7.68	310	
	9		9	12	2,000	2,000	2,800	1,800	6,800	8,400	440	1,820	2,700	2.3	8.3	12.4	3.74	A++	7.68	310	
	9		9	18	1,700	1,700	3,400	1,800	6,800	8,400	440	1,810	2,690	2.3	8.2	12.3	3.76	A++	7.69	310	
	9	12	12	1,780	2,510	2,510	1,800	6,800	8,400	440	1,810	2,700	2.3	8.2	12.4	3.76	A++	7.69	310		
	9	12	18	1,550	2,160	3,090	1,800	6,800	8,400	440	1,800	2,700	2.3	8.1	12.4	3.78	A++	7.69	309		
12	12	12	2,260	2,270	2,270	1,800	6,800	8,400	440	1,800	2,710	2.3	8.1	12.4	3.78	A++	7.69	309			

Heating

Outdoor Unit	A	B	C	Heating Capacity			Capacity			Power Consumption			Current			Effic. NOM. Heating at 7 °C/20 °C EER	Seasonal Efficiency (According to EN14825) Class	SCOP	P design kWh	Qhe kWh
				W			W			W			A							
				A	B															

Combination guide

4-5. AJ080TXJ4KG/EU

Cooling

Outdoor Unit	A	B	C	D	Cooling Capacity				Capacity			Power Consumption			Current			Effic. NOM. Cooling at 35 °C/ 27 °C EER	Seasonal Efficiency (According to EN14825) Class	SEER	Qce kWh	
					W				W			W			A							
					A	B	C	D	MIN	STD	MAX	MIN	STD	MAX	MIN	STD	MAX					
AJ080TXJ4KG	2 Unit	7	7			2,000	2,000			1,640	4,000	4,800	410	1,110	1,490	1.9	4.9	6.8	3.60	A++	7.55	185
		7	9			2,040	2,560			1,690	4,600	5,520	420	1,310	1,720	1.9	5.8	7.9	3.51	A++	7.47	216
		7	12			2,000	3,500			1,770	5,500	6,600	430	1,570	2,050	2.0	6.9	9.4	3.50	A++	7.14	270
		7	18			2,060	5,140			1,900	7,200	8,640	580	2,050	2,690	2.7	8.9	12.3	3.51	A++	7.31	345
		7	24			1,690	5,760			1,900	7,450	8,640	580	2,130	2,730	2.7	9.3	12.5	3.50	A++	7.25	359
		9	9			2,600	2,600			1,750	5,200	6,240	420	1,480	2,000	1.9	6.5	9.2	3.51	A++	7.3	249
	9	12			2,540	3,560			1,820	6,100	7,320	440	1,680	2,260	2.0	7.4	10.3	3.63	A++	7.46	286	
	9	18			2,400	4,800			1,900	7,200	8,640	580	2,050	2,690	2.7	8.9	12.3	3.51	A++	7.31	345	
	9	24			2,030	5,520			1,900	7,550	8,760	580	2,150	2,760	2.7	9.4	12.6	3.51	A++	7.26	364	
	12	12			3,500	3,500			1,900	7,000	8,000	580	2,000	2,620	2.7	8.7	12.0	3.50	A++	7.3	336	
	12	18			3,030	4,320			1,900	7,350	8,820	580	2,110	2,750	2.7	9.2	12.6	3.48	A++	7.27	354	
	12	24			2,620	5,080			1,900	7,700	8,930	580	2,180	2,780	2.7	9.5	12.7	3.53	A++	7.21	377	
	18	18			3,830	3,830			1,900	7,660	9,180	580	2,120	2,860	2.7	9.2	13.1	3.61	A++	7.21	372	
	18	24			3,310	4,490			1,900	7,800	8,970	580	2,150	2,820	2.7	9.4	12.9	3.63	A++	7.22	378	
	3 Unit	7	7	7		2,000	2,000	2,000		1,810	6,000	7,200	440	1,620	2,310	2.0	6.9	10.6	3.70	A++	7.62	276
		7	7	9		2,030	2,030	2,540		1,870	6,600	7,920	440	1,810	2,500	2.0	7.7	11.4	3.65	A++	7.58	305
		7	7	12		1,920	1,920	3,360		1,900	7,200	9,000	580	2,020	2,780	2.7	8.6	12.7	3.56	A++	7.45	338
		7	7	18		1,680	1,680	4,190		1,900	7,550	9,180	580	2,130	2,730	2.7	9.1	12.5	3.54	A++	7.75	341
7		7	24		1,480	1,480	5,040		1,900	8,000	9,300	580	2,090	2,870	2.7	8.9	13.1	3.83	A++	7.75	361	
7		9	9		2,000	2,500	2,500		1,900	7,000	8,640	580	1,930	2,680	2.7	8.2	12.3	3.63	A++	7.35	348	
7		9	12		1,830	2,280	3,200		1,900	7,310	9,060	580	2,030	2,690	2.7	8.6	12.3	3.60	A++	7.75	330	
7		9	18		1,610	2,010	4,030		1,900	7,650	9,250	580	2,050	2,730	2.7	8.7	12.5	3.73	A++	7.81	343	
7		9	24		1,420	1,770	4,810		1,900	8,000	9,300	580	2,030	2,870	2.7	8.7	13.1	3.94	A++	7.77	360	
7		12	12		1,680	2,930	2,930		1,900	7,540	9,160	580	2,070	2,730	2.7	8.8	12.5	3.64	A++	7.78	339	
7		12	18		1,500	2,630	3,750		1,900	7,880	9,300	580	2,050	2,820	2.7	8.7	12.9	3.84	A++	7.74	356	
7		18	18		1,330	3,330	3,330		1,900	8,000	9,300	580	2,010	2,910	2.7	8.6	13.3	3.98	A++	7.78	360	
9		9	9		2,400	2,400	2,400		1,900	7,200	9,030	580	1,950	2,640	2.7	8.3	12.1	3.69	A++	7.77	324	
9		9	12		2,180	2,180	3,060		1,900	7,420	9,130	580	2,040	2,690	2.7	8.7	12.3	3.64	A++	7.77	334	
9		9	18		1,940	1,940	3,890		1,900	7,770	9,300	580	1,950	2,780	2.7	8.3	12.7	3.98	A++	7.77	350	
9		9	24		1,690	1,690	4,610		1,900	8,000	9,300	580	2,000	2,910	2.7	8.5	13.3	4.00	A++	7.79	359	
9		12	12		2,010	2,820	2,820		1,900	7,650	9,230	580	2,080	2,730	2.7	8.9	12.5	3.68	A++	7.79	344	
9		12	18		1,820	2,550	3,640		1,900	8,000	9,300	580	2,020	2,870	2.7	8.6	13.1	3.96	A++	7.78	360	
12	12	12		2,630	2,630	2,630		1,900	7,890	9,300	580	2,120	2,820	2.7	9.0	12.9	3.72	A++	7.71	358		
12	12	18		2,330	2,330	3,330		1,900	8,000	9,300	580	2,110	2,910	2.7	9.0	13.3	3.79	A++	7.74	362		
4 Unit	7	7	7	7	1,830	1,830	1,830	1,830	1,900	7,320	9,050	580	1,800	2,690	2.7	8.2	12.3	4.06	A++	7.67	334	
	7	7	7	9	1,750	1,750	1,750	2,190	1,900	7,440	9,120	580	1,850	2,690	2.7	8.4	12.3	4.02	A++	7.67	340	
	7	7	7	12	1,610	1,610	1,610	2,820	1,900	7,650	9,220	580	1,900	2,730	2.7	8.6	12.5	4.03	A++	7.69	348	
	7	7	7	18	1,450	1,450	1,450	3,650	1,900	8,000	9,300	580	2,000	2,870	2.7	9.0	13.1	4.00	A++	7.7	364	
	7	7	9	9	1,680	1,680	2,090	2,090	1,900	7,540	9,180	580	1,870	2,730	2.7	8.5	12.5	4.03	A++	7.68	344	
	7	7	9	12	1,550	1,550	1,940	2,720	1,900	7,760	9,280	580	1,940	2,780	2.7	8.8	12.7	4.00	A++	7.69	353	
	7	7	9	18	1,390	1,390	1,740	3,480	1,900	8,000	9,300	580	1,970	2,870	2.7	8.9	13.1	4.06	A++	7.72	363	
	7	7	12	12	1,450	1,450	2,550	2,550	1,900	8,000	9,300	580	1,990	2,870	2.7	9.0	13.1	4.02	A++	7.71	363	
	7	9	9	9	1,610	2,010	2,010	2,010	1,900	7,650	9,250	580	1,900	2,730	2.7	8.6	12.5	4.03	A++	7.69	348	
	7	9	9	12	1,500	1,880	1,880	2,630	1,900	7,890	9,300	580	1,960	2,820	2.7	8.9	12.9	4.03	A++	7.7	359	
	7	9	9	18	1,330	1,670	1,670	3,330	1,900	8,000	9,300	580	1,970	2,910	2.7	8.9	13.3	4.06	A++	7.72	363	
	7	9	12	12	1,400	1,740	2,430	2,430	1,900	8,000	9,300	580	1,970	2,870	2.7	8.9	13.1	4.06	A++	7.72	363	
	9	9	9	9	1,940	1,940	1,940	1,940	1,900	7,760	9,300	580	1,940	2,780	2.7	8.8	12.7	4.00	A++	7.69	353	
	9	9	9	12	1,820	1,820	1,820	2,540	1,900	8,000	9,300	580	1,970	2,870	2.7	8.9	13.1	4.06	A++	7.72	363	
	9	9	12	12	1,670	1,670	2,330	2,330	1,900	8,000	9,300	580	1,970	2,910	2.7	8.9	13.3	4.06	A++	7.72	363	

Heating

Outdoor Unit	A	B	C	D	Heating Capacity				Capacity			Power Consumption			Current			Effic. NOM. Heating at 7 °C/20 °C COP ¹	Seasonal Efficiency (According to EN14825) Class	SCOP	p design kW	Qhe kWh	
					W				W			W			A								
					A	B	C	D	MIN	STD	MAX	MIN	STD	MAX	MIN	STD	MAX						
AJ080TXJ4KG	2 Unit	7	7			2,200	2,200			1,980	4,400	5,060	600	1,150	1,530	2.7	4.9	7.0	3.83	A+	4.25	3.05	1,006
		7	9			2,040	3,060			2,040	5,100	5,870	610	1,290	1,700	2.8	5.5	7.8	3.95	A+	4.20	4.21	1,401
		7	12			2,130	3,870			2,110	6,000	6,900	610	1,530	2,110	2.8	6.5	9.7	3.92	A+	4.11	4.91	1,669
		7	18			2,090	5,710			2,200	7,800	9,130	620	1,920	2,580	2.8	8.2	11.8	4.06	A+	4.18	5.09	1,705
		7	24			1,790	6,330			2,200	8,120	9,300	620	2,000	2,600	2.8	8.5	11.9	4.06	A+	4.18	5.2	1,742
		9	9			2,900	2,900			2,100	5,800	6,670	610	1,470	1,930	2.8	6.3	8.8	3.94	A+	4.11	4.91	1,669
	9	12			3,030	3,670			2,170	6,700	7,710	610	1,730	2,330	2.8	7.4	10.7	3.87	A+	4.11	4.91	1,669	
	9	18			2,770	5,030			2,200	7,800	9,360	620	1,920	2,600	2.8	8.2	11.9	4.06	A+	4.18	5.09	1,705	
	9	24			2,480	5,870			2,200	8,350	9,600	620	2,220	2,700	2.8	9.5	12.4	3.94	A+	4.18	5.2	1,742	
	12	12			3,800	3,800			2,200	7,600	8,740	620	1,890	2,510	2.8	8.1	11.5	4.02	A+	4.18	5.09	1,705	
	12	18			3,250	4,870			2,200	8,120	9,500	620	2,000	2,650	2.8	8.5	12.1	4.06	A+	4.18	5.09	1,705	
	12	24			2,860	5,590			2,200	8,450	9,700	620	2,100	2,700	2.8	8.9	12.4	4.02	A+	4.18	5.09	1,705	
	18	18			4,250	4,250			2,200	8,500	9,950	620	2,080	2,750	2.8	8.9	12.6	4.09	A+	4.10	5.88	2,010	
	18	24			3,760	4,890			2,200	8,650	9,900	620	2,110	2,800	2.8	9.0	12.8	4.10	A+	4.10	5.88		

Combination guide

4-6. AJ100TXJ5KG/EU

Cooling

Outdoor Unit	A	B	C	D	E	Cooling Capacity					Capacity			Power Consumption			Current			Effic. NOM. Cooling at 35°C/27°C EER	Seasonal Efficiency (According to EN14825) Class	SEER	Qce kWh
						W					W			W			A						
						A	B	C	D	E	MIN	STD	MAX	MIN	STD	MAX	MIN	STD	MAX				
AJ100TXJ5KG	2 Unit	7	7				2,000	2,000			1,680	4,000	4,900	610	1,110	1,650	2.8	4.7	7.6	3.60	A++	7.28	192
		7	9				2,000	2,500			1,680	4,500	5,530	610	1,270	1,860	2.8	5.4	8.5	3.55	A++	7.39	213
		7	12				2,000	3,500			1,710	5,500	6,950	620	1,570	2,330	2.8	6.7	10.7	3.50	A++	7.40	260
		7	18				2,000	5,000			2,210	7,000	8,690	630	1,970	2,910	2.9	8.4	13.3	3.55	A++	7.37	332
		7	24				1,830	6,240			2,280	8,070	10,110	650	2,290	3,390	3.0	9.8	15.5	3.52	A++	7.30	387
		9	9				2,500	2,500			1,680	5,000	6,320	610	1,400	2,120	2.8	6.0	9.7	3.58	A++	7.49	234
		9	12				2,500	3,500			1,710	6,000	7,270	620	1,690	2,430	2.8	7.2	11.1	3.55	A++	7.46	282
		9	18				2,500	5,000			2,210	7,500	9,320	630	2,140	3,120	2.9	9.1	14.3	3.51	A++	7.33	358
		9	24				2,190	5,960			2,280	8,150	10,110	650	2,340	3,390	3.0	10.0	15.5	3.48	A++	7.30	391
		12	12				3,500	3,500			2,170	7,000	8,530	620	1,960	2,850	2.8	8.4	13.0	3.58	A++	7.38	332
	12	18				3,300	4,720			2,240	8,020	9,950	640	2,260	3,330	2.9	9.6	15.2	3.55	A++	7.31	386	
	12	24				2,920	5,670			2,480	8,590	10,740	660	2,480	3,600	3.0	10.6	16.5	3.47	A++	7.15	420	
	18	18				4,280	4,280			2,440	8,560	10,430	650	2,460	3,500	3.0	10.5	16.0	3.48	A++	7.15	419	
	18	24				3,740	5,080			2,510	8,820	10,900	670	2,470	3,670	3.1	10.5	16.8	3.57	A++	7.29	423	
	24	24				4,550	4,550			3,110	9,100	11,000	690	2,560	3,740	3.2	10.9	17.1	3.55	A++	7.30	436	
	3 Unit	7	7	7			2,000	2,000	2,000		1,760	6,000	7,270	640	1,660	2,460	2.9	7.1	11.3	3.62	A++	7.48	281
		7	7	9			2,000	2,000	2,500		1,760	6,500	7,900	640	1,780	2,660	2.9	7.6	12.2	3.65	A++	7.48	281
		7	7	12			2,000	2,000	3,500		2,280	7,500	8,850	650	2,080	2,980	3.0	8.9	13.6	3.61	A++	7.52	349
		7	7	18			1,930	1,930	4,830		2,310	8,690	10,270	660	2,500	3,450	3.0	10.7	15.8	3.48	A++	7.91	391
		7	7	24			1,660	1,660	5,650		2,550	8,970	10,430	680	2,560	3,530	3.1	10.9	16.2	3.51	A++	7.65	411
7		9	9			2,000	2,500	2,500		2,240	7,000	8,370	640	1,920	2,820	2.9	8.2	12.9	3.64	A++	7.50	326	
7		9	12			2,000	2,500	3,500		2,280	8,000	9,320	650	2,230	3,130	3.0	9.5	14.3	3.58	A++	7.77	361	
7		9	18			1,850	2,310	4,620		2,310	8,780	10,270	660	2,480	3,450	3.0	10.6	15.8	3.54	A++	7.92	388	
7		9	24			1,550	1,940	5,270		2,550	8,760	10,430	680	2,470	3,530	3.1	10.5	16.2	3.54	A++	7.92	387	
7		12	12			1,930	3,380	3,380		2,280	8,690	10,270	650	2,500	3,440	3.0	10.7	15.7	3.48	A++	7.91	391	
7		12	18			1,700	2,980	4,250		2,510	8,930	10,430	670	2,590	3,510	3.1	11.0	16.1	3.45	A++	7.90	396	
7		12	24			1,460	2,550	4,950		2,760	8,960	10,740	690	2,550	3,630	3.2	10.9	16.6	3.51	A++	7.65	410	
7		18	18			1,480	3,710	3,710		2,720	8,900	10,740	680	2,540	3,630	3.1	10.8	16.6	3.50	A++	7.92	394	
7		18	24			1,340	3,360	4,560		3,150	9,260	11,000	700	2,570	3,750	3.2	11.0	17.2	3.61	A++	7.75	418	
7		24	24			1,260	4,270	4,270		3,240	9,800	11,000	720	2,720	3,770	3.3	11.6	17.3	3.60	A++	7.77	442	
9		9	9			2,500	2,500	2,500		2,240	7,500	8,850	640	2,080	2,970	2.9	8.9	13.6	3.61	A++	7.52	349	
9		9	12			2,500	2,500	3,500		2,280	8,500	9,950	650	2,390	3,340	3.0	10.2	15.3	3.55	A++	7.91	376	
9		9	18			2,210	2,210	4,430		2,480	8,850	10,270	660	2,520	3,450	3.0	10.7	15.8	3.51	A++	7.92	391	
9		9	24			1,880	1,880	5,110		2,550	8,870	10,740	680	2,530	3,630	3.1	10.8	16.6	3.51	A++	7.92	392	
9		12	12			2,310	3,230	3,230		2,280	8,770	10,270	650	2,440	3,440	3.0	10.4	15.7	3.59	A++	7.93	387	
9	12	18			1,980	2,770	3,950		2,510	8,700	10,430	670	2,420	3,510	3.1	10.3	16.1	3.59	A++	7.93	384		
9	12	24			1,770	2,480	4,810		2,760	9,060	10,900	690	2,570	3,690	3.2	11.0	16.9	3.52	A++	7.66	414		
9	18	18			1,800	3,600	3,600		2,720	9,000	10,900	680	2,560	3,680	3.1	10.9	16.8	3.52	A++	7.65	412		
9	18	24			1,640	3,270	4,450		3,150	9,360	11,000	700	2,590	3,750	3.2	11.0	17.2	3.61	A++	7.75	423		
9	24	24			1,520	4,140	4,140		3,240	9,800	11,000	720	2,660	3,770	3.3	11.3	17.3	3.68	A++	7.79	440		
12	12	12			2,980	2,980	2,980		2,480	8,940	10,430	660	2,410	3,500	3.0	10.3	16.0	3.71	A++	7.98	392		
12	12	18			2,600	2,600	3,710		2,680	8,910	10,740	670	2,410	3,620	3.1	10.3	16.6	3.69	A++	7.97	391		
12	12	24			2,350	2,350	4,560		3,110	9,260	11,000	690	2,540	3,740	3.2	10.8	17.1	3.64	A++	7.75	418		
12	18	18			2,390	3,410	3,410		3,110	9,210	11,000	690	2,530	3,740	3.2	10.8	17.1	3.64	A++	7.75	416		
12	18	24			2,240	3,200	4,360		3,200	9,800	11,000	710	2,750	3,760	3.2	11.7	17.2	3.57	A++	7.75	442		
12	24	24			2,000	3,900	3,900		3,290	9,800	11,000	730	2,750	3,780	3.3	11.7	17.3	3.57	A++	7.75	442		
18	18	18			3,260	3,270	3,270		3,150	9,800	11,000	700	2,750	3,750	3.2	11.7	17.2	3.57	A++	7.75	442		
18	18	24			2,920	2,920	3,960		3,240	9,800	11,000	720	2,750	3,770	3.3	11.7	17.3	3.57	A++	7.75	442		

Outdoor Unit	A	B	C	D	E	Cooling Capacity					Capacity			Power Consumption			Current			Effic. NOM. Cooling at 35°C/27°C EER	Seasonal Efficiency (According to EN14825) Class	SEER	Qce kWh
						W					W			W			A						
						A	B	C	D	E	MIN	STD	MAX	MIN	STD	MAX	MIN	STD	MAX				
AJ100TXJ5KG	4 Unit	7	7	7	7		2,000	2,000	2,000	2,000	2,350	8,000	9,320	670	2,170	3,160	3.1	9.2	14.5	3.68	A++	7.79	359
		7	7	7	9		2,000	2,000	2,000	2,500	2,350	8,500	9,950	670	2,290	3,360	3.1	9.8	15.4	3.71	A++	7.95	374
		7	7	7	12		1,850	1,850	1,850	3,230	2,380	8,780	10,270	680	2,390	3,470	3.1	10.2	15.9	3.68	A++	7.96	386
		7	7	7	18		1,580	1,580	1,580	3,950	2,590	8,690	10,430	690	2,330	3,540	3.2	9.9	16.2	3.73	A++	7.97	382
		7	7	7	24		1,420	1,420	1,420	4,820	2,840	9,080	10,900	710	2,460	3,710	3.2	10.5	17.0	3.69	A++	7.71	412
		7	7	9	9		1,930	1,930	2,420	2,420	2,350	8,700	10,270	670	2,330	3,460	3.1	9.9	15.8	3.73	A++	7.97	382
		7	7	9	12		1,770	1,770	2,210	3,100	2,550	8,850	10,270	680	2,420	3,470	3.1	10.3	15.9	3.66	A++	7.96	389
		7	7	9	18		1,530	1,53															

Combination guide

4-6. AJ100TXJ5KG/EU

Outdoor Unit	A	B	C	D	E	Cooling Capacity					Capacity			Power Consumption			Current			Effic. NOM. Cooling at 35 °C/27 °C	Seasonal Efficiency (According to EN14825) Class	SEER	Qce kWh	
						W					W			W			A							
						A	B	C	D	E	MIN	STD	MAX	MIN	STD	MAX	MIN	STD	MAX					MIN
AJ100TXJ5KG	5 Unit	7	7	7	7	7	1900	1900	1900	1900	1900	2,630	9,500	10,270	700	2,570	3,490	3.2	11.5	16.0	3.69	A++	7.78	427
		7	7	7	7	9	1,820	1,820	1,820	1,820	2,270	2,630	9,550	10,430	700	2,600	3,550	3.2	11.6	16.2	3.68	A++	7.78	430
		7	7	7	7	12	1,680	1,680	1,680	1,680	2,940	2,660	9,660	10,740	710	2,630	3,650	3.2	11.7	16.7	3.68	A++	7.78	434
		7	7	7	7	18	1,540	1,540	1,540	1,540	3,840	3,240	10,000	10,900	720	2,750	3,720	3.3	12.2	17.0	3.64	A++	7.79	449
		7	7	7	7	24	1,350	1,350	1,350	1,350	4,600	3,330	10,000	11,000	740	2,750	3,790	3.4	12.2	17.3	3.64	A++	7.79	449
		7	7	7	9	9	1,750	1,750	1,750	2,180	2,180	2,630	9,610	10,430	700	2,610	3,550	3.2	11.6	16.2	3.68	A++	7.78	432
		7	7	7	9	12	1,620	1,620	1,620	2,020	2,830	2,840	9,710	10,740	710	2,670	3,650	3.2	11.9	16.7	3.64	A++	7.77	437
		7	7	7	9	18	1,480	1,480	1,480	1,860	3,700	3,240	10,000	11,000	720	2,730	3,770	3.3	12.1	17.3	3.66	A++	7.79	449
		7	7	7	9	24	1,310	1,310	1,310	1,630	4,440	3,330	10,000	11,000	740	2,730	3,790	3.4	12.1	17.3	3.66	A++	7.79	449
		7	7	7	12	12	1,540	1,540	1,540	2,690	2,690	3,200	10,000	10,900	710	2,750	3,710	3.2	12.2	17.0	3.64	A++	7.79	449
		7	7	7	12	18	1,380	1,380	1,380	2,410	3,450	3,290	10,000	11,000	730	2,760	3,780	3.3	12.3	17.3	3.62	A++	7.78	450
		7	7	7	12	24	1,230	1,230	1,230	2,150	4,160	3,380	10,000	11,000	750	2,760	3,800	3.4	12.3	17.4	3.62	A++	7.78	450
		7	7	7	18	18	1,240	1,240	1,240	3,140	3,140	3,330	10,000	11,000	740	2,760	3,790	3.4	12.3	17.3	3.62	A++	7.78	450
		7	7	9	9	9	1,680	1,680	2,100	2,100	2,100	2,630	9,660	10,740	700	2,630	3,650	3.2	11.7	16.7	3.68	A++	7.78	434
		7	7	9	9	12	1,600	1,600	2,000	2,000	2,800	2,840	9,710	10,900	710	2,670	3,710	3.2	12.2	17.0	3.64	A++	7.79	449
		7	7	9	9	18	1,430	1,430	1,790	1,790	3,560	3,240	10,000	11,000	720	2,760	3,770	3.3	12.3	17.3	3.62	A++	7.78	450
		7	7	9	9	24	1,270	1,270	1,580	1,580	4,300	3,330	10,000	11,000	740	2,760	3,790	3.4	12.3	17.3	3.62	A++	7.78	450
		7	7	9	12	12	1,480	1,480	1,860	2,590	2,590	3,200	10,000	11,000	710	2,750	3,760	3.2	12.2	17.2	3.64	A++	7.79	449
		7	7	9	12	18	1,330	1,330	1,680	2,330	3,330	3,290	10,000	11,000	730	2,780	3,780	3.3	12.3	17.3	3.60	A++	7.78	450
		7	7	9	12	24	1,190	1,190	1,490	2,080	4,050	3,380	10,000	11,000	750	2,780	3,800	3.4	12.3	17.4	3.60	A++	7.78	450
		7	7	9	18	18	1,210	1,210	1,520	3,030	3,030	3,330	10,000	11,000	740	2,780	3,790	3.4	12.3	17.3	3.60	A++	7.78	450
		7	7	12	12	12	1,370	1,370	2,420	2,420	2,420	3,240	10,000	11,000	720	2,750	3,770	3.3	12.2	17.3	3.64	A++	7.79	449
		7	7	12	12	18	1,250	1,250	2,190	2,190	3,120	3,290	10,000	11,000	730	2,760	3,780	3.3	12.3	17.3	3.62	A++	7.78	450
		7	9	9	9	9	1,620	2,020	2,020	2,020	2,020	2,800	9,700	10,740	700	2,610	3,650	3.2	11.6	16.7	3.71	A++	7.79	436
		7	9	9	9	12	1,550	1,920	1,920	1,920	2,690	3,200	10,000	10,900	710	2,750	3,710	3.2	12.2	17.0	3.64	A++	7.79	449
		7	9	9	9	18	1,390	1,720	1,720	1,720	3,450	3,240	10,000	11,000	720	2,760	3,770	3.3	12.3	17.3	3.62	A++	7.78	450
		7	9	9	9	24	1,240	1,530	1,530	1,530	4,170	3,330	10,000	11,000	740	2,760	3,790	3.4	12.3	17.3	3.62	A++	7.78	450
		7	9	9	12	12	1,440	1,790	1,790	2,490	2,490	3,200	10,000	11,000	710	2,720	3,760	3.2	12.1	17.2	3.68	A++	7.78	434
		7	9	9	12	18	1,290	1,610	1,610	2,260	3,230	3,290	10,000	11,000	730	2,760	3,780	3.3	12.3	17.3	3.62	A++	7.78	450
		7	9	9	12	24	1,160	1,450	1,450	2,020	3,920	3,380	10,000	11,000	750	2,760	3,800	3.4	12.3	17.4	3.62	A++	7.78	450
		7	9	9	18	18	1,180	1,470	1,470	2,940	2,940	3,330	10,000	11,000	740	2,780	3,790	3.4	12.3	17.3	3.60	A++	7.78	450
		7	9	12	12	12	1,340	1,670	2,330	2,330	2,330	3,240	10,000	11,000	720	2,750	3,770	3.3	12.2	17.3	3.64	A++	7.79	449
		7	9	12	12	18	1,210	1,520	2,120	2,120	3,030	3,290	10,000	11,000	730	2,750	3,780	3.3	12.2	17.3	3.64	A++	7.79	449
		9	9	9	9	9	2,000	2,000	2,000	2,000	2,000	3,000	10,000	11,000	700	2,750	3,700	3.2	12.2	16.9	3.64	A++	7.79	449
		9	9	9	9	12	1,850	1,850	1,850	1,850	2,600	3,200	10,000	11,000	710	2,750	3,760	3.2	12.2	17.2	3.64	A++	7.79	449
		9	9	9	9	18	1,670	1,670	1,670	1,670	3,320	3,240	10,000	11,000	720	2,760	3,770	3.3	12.3	17.3	3.62	A++	7.78	450
		9	9	9	9	24	1,490	1,490	1,490	1,490	4,040	3,330	10,000	11,000	740	2,760	3,790	3.4	12.3	17.3	3.62	A++	7.78	450
		9	9	9	12	12	1,720	1,720	1,720	2,420	2,420	3,200	10,000	11,000	710	2,750	3,760	3.2	12.2	17.2	3.64	A++	7.79	449
		9	9	9	12	18	1,560	1,560	1,560	2,190	3,130	3,290	10,000	11,000	730	2,760	3,780	3.3	12.3	17.3	3.62	A++	7.78	450
		9	9	12	12	12	1,610	1,610	2,260	2,260	2,260	3,240	10,000	11,000	720	2,750	3,770	3.3	12.2	17.3	3.64	A++	7.79	449
9	9	12	12	18	1,470	1,470	2,060	2,060	2,940	3,290	10,000	11,000	730	2,760	3,780	3.3	12.3	17.3	3.62	A++	7.78	450		
9	12	12	12	12	1,520	2,120	2,120	2,120	2,120	3,240	10,000	11,000	720	2,750	3,770	3.3	12.2	17.3	3.64	A++	7.79	449		

Heating

Outdoor Unit	A	B	C	D	E	Heating Capacity					Capacity			Power Consumption			Current			Effic. NOM. Heating at 7 °C/ 20 °C	Seasonal Efficiency (According to EN14825) Class	SCOP	P design kW	Qhe kWh	
						W					W			W			A								
						A	B	C	D	E	MIN	STD	MAX	MIN	STD	MAX	MIN	STD	MAX						MIN
AJ100TXJ5KG	2 Unit	7	7				2,200	2,200				1,240	4,400	5,530	460	1,070	1,520	2.1	4.6	7.0	4.10	A+	4.16	3.05	1,028
		7	9				2,200	3,300				1,240	5,500	6,790	460	1,360	1,850	2.1	5.8	8.5	4.05	A+	4.15	4.21	1,418
		7	12				2,200	4,000				1,270	6,200	7,580	470	1,490	2,060	2.2	6.3	9.4	4.15	A+	4.19	4.91	1,638
		7	18				2,200	6,000				1,300	8,200	10,110	480	2,010	2,750	2.2	8.6	12.6	4.08	A+	4.09	5.88	2,010
		7	24				2,200	7,800				1,500	10,000	12,480	500	2,490	3,390	2.3	10.6	15.5	4.01	A+	4.03	7.70	2,671
		9	9				3,300	3,300				1,240	6,600	8,220	460	1,630	2,230	2.1	6.9	10.2	4.06	A+	4.19	4.91	1,638
		9	12				3,300	4,000				1,270	7,300	9,010	470	1,810	2,440	2.2	7.7	11.2	4.04	A+	4.19	4.91	1,638
		9	18				3,300	6,000				1,300	9,300	11,690	480	2,320	3,160	2.2	9.9	14.5	4.01	A+	4.03	7.70	2,671
		9	24				3,150	7,450				1,500	10,600	13,110	500	2,640	3,560	2.3	11.2	16.3	4.02	A+	4.03	7.70	2,671
		12	12				4,000	4,000				1,270	8,000	9,800	470	1,940	2,650	2.2	8.3	12.1	4.13	A+	4.19	4.91	1,638
		12	18				4,000	6,000				1,470	10,000	12,320	490	2,490	3,330	2.2	10.6	15.2	4.01	A+	4.03	7.70	2,671
		12	24				3,590	7,010				1,530	10,600	13,110	510	2,670	3,560	2.3	11.4	16.3	3.97	A+	4.03	7.70	2,671
	18	18				5,300	5,300				1,650	10,600	13,110	500	2,660	3,560	2.3	11.3	16.3	3.99	A+	4.03	7.70	2,671	
	18	24				4,610	5,990				1,820	10,600	13,110	520	2,640	3,580	2.4	11.2	16.4	4.02	A+	4.03	7.70	2,671	
	24	24				5,300	5,300				2,160	10,600	12,960	540	2,640	3,560	2.5	11.2							

Combination guide

Outdoor Unit	A	B	C	D	E	Heating Capacity					Capacity			Power Consumption			Current			Effic. NOM. Heating at 7 °C/ 20 °C COP ¹	Seasonal Efficiency (According to EN14825) Class	SCOP	P design kW	Qhe kWh
						W					W			W			A							
						A	B	C	D	E	MIN	STD	MAX	MIN	STD	MAX	MIN	STD	MAX					
AJ100TXJ5KG	4	Unit	7	7	7	7	2,200	2,200	2,200	2,200	1,400	8,800	9,800	520	2,110	2,700	2.4	9.0	12.4	4.18	A+	4.25	791	2,607
			7	7	7	9	2,140	2,140	2,140	3,210	1,560	9,630	11,380	520	2,320	3,120	2.4	9.9	14.3	4.15	A+	4.25	791	2,607
			7	7	7	12	2,010	2,010	2,010	3,660	1,590	9,690	12,170	530	2,330	3,330	2.4	9.9	15.2	4.15	A+	4.25	791	2,607
			7	7	7	18	1,730	1,730	1,730	4,710	1,780	9,900	12,170	540	2,410	3,350	2.5	10.3	15.3	4.11	A+	4.25	791	2,607
			7	7	7	24	1,630	1,630	1,630	5,770	1,960	10,660	12,320	560	2,620	3,410	2.6	11.2	15.6	4.07	A+	4.25	791	2,607
			7	7	9	9	1,950	1,950	2,920	2,920	1,560	9,740	11,530	520	2,350	3,160	2.4	10.0	14.5	4.15	A+	4.25	791	2,607
			7	7	9	12	1,840	1,840	2,760	3,350	1,590	9,790	11,850	530	2,390	3,250	2.4	10.2	14.9	4.09	A+	4.25	791	2,607
			7	7	9	18	1,610	1,610	2,410	4,380	1,890	10,010	12,170	540	2,440	3,350	2.5	10.4	15.3	4.11	A+	4.25	791	2,607
			7	7	9	24	1,530	1,530	2,290	5,410	1,960	10,760	12,480	560	2,620	3,450	2.6	11.2	15.8	4.10	A+	4.25	791	2,607
			7	7	12	12	1,750	1,750	3,190	3,190	1,750	9,880	12,170	530	2,360	3,340	2.4	10.1	15.3	4.19	A+	4.25	791	2,607
			7	7	12	18	1,630	1,630	2,960	4,440	1,930	10,660	12,320	550	2,610	3,390	2.5	11.1	15.5	4.09	A+	4.25	791	2,607
			7	7	12	24	1,470	1,470	2,670	5,210	2,280	10,820	12,800	570	2,630	3,540	2.6	11.2	16.2	4.11	A+	4.25	791	2,607
			7	7	18	18	1,460	1,460	3,970	3,970	2,240	10,860	12,800	560	2,640	3,530	2.6	11.2	16.2	4.11	A+	4.25	791	2,607
			7	7	18	24	1,330	1,330	3,630	4,710	2,320	11,000	12,960	580	2,680	3,600	2.7	11.4	16.5	4.10	A+	4.25	791	2,607
			7	9	9	9	1,790	2,690	2,690	2,690	1,720	9,860	12,170	530	2,390	3,330	2.4	10.2	15.2	4.13	A+	4.25	791	2,607
			7	9	9	12	1,710	2,560	2,560	3,100	1,750	9,930	12,320	530	2,410	3,370	2.4	10.3	15.4	4.12	A+	4.25	791	2,607
			7	9	9	18	1,590	2,380	2,380	4,330	1,890	10,680	12,480	540	2,620	3,430	2.5	11.2	15.7	4.08	A+	4.25	791	2,607
			7	9	9	24	1,440	2,160	2,160	5,100	2,240	10,860	12,960	560	2,670	3,580	2.6	11.4	16.4	4.07	A+	4.25	791	2,607
			7	9	12	12	1,630	2,440	2,960	2,960	1,860	9,990	12,170	530	2,440	3,340	2.4	10.4	15.3	4.10	A+	4.25	791	2,607
			7	9	12	18	1,530	2,290	2,780	4,170	1,930	10,770	12,480	550	2,640	3,440	2.5	11.2	15.7	4.08	A+	4.25	791	2,607
			7	9	12	24	1,400	2,100	2,540	4,960	2,280	11,000	12,960	570	2,680	3,580	2.6	11.4	16.4	4.11	A+	4.25	791	2,607
			7	9	18	18	1,390	2,070	3,770	3,770	2,240	11,000	12,960	560	2,680	3,580	2.6	11.4	16.4	4.11	A+	4.25	791	2,607
			7	9	18	24	1,250	1,880	3,420	4,450	2,320	11,000	13,110	580	2,680	3,640	2.7	11.4	16.7	4.11	A+	4.25	791	2,607
			7	12	12	12	1,560	2,830	2,830	2,830	1,890	10,050	12,320	540	2,420	3,380	2.5	10.3	15.5	4.15	A+	4.25	791	2,607
			7	12	12	18	1,470	2,670	2,670	4,010	2,200	10,820	12,800	550	2,650	3,520	2.5	11.3	16.1	4.08	A+	4.25	791	2,607
			7	12	12	24	1,350	2,440	2,440	4,770	2,280	11,000	12,960	570	2,680	3,590	2.6	11.4	16.4	4.11	A+	4.25	791	2,607
			7	12	18	18	1,330	2,410	3,630	3,630	2,280	11,000	12,960	570	2,680	3,580	2.6	11.4	16.4	4.11	A+	4.25	791	2,607
			7	12	18	24	1,210	2,200	3,300	4,290	2,360	11,000	13,430	590	2,680	3,730	2.7	11.4	17.1	4.11	A+	4.25	791	2,607
			7	18	18	18	1,190	3,270	3,270	3,270	2,320	11,000	13,430	580	2,680	3,720	2.7	11.4	17.0	4.11	A+	4.25	791	2,607
			9	9	9	9	2,490	2,490	2,490	2,490	1,820	9,960	12,480	520	2,310	3,410	2.4	9.8	15.6	4.32	A+	4.32	791	2,564
			9	9	9	12	2,380	2,380	2,380	2,880	1,860	10,020	12,320	530	2,340	3,370	2.4	10.0	15.4	4.28	A+	4.25	791	2,607
			9	9	9	18	2,240	2,240	2,240	4,080	2,160	10,800	12,800	540	2,610	3,510	2.5	11.1	16.1	4.14	A+	4.25	791	2,607
			9	9	9	24	2,050	2,050	2,050	4,850	2,240	11,000	12,960	560	2,680	3,580	2.6	11.4	16.4	4.11	A+	4.25	791	2,607
			9	9	12	12	2,410	2,410	2,920	2,920	1,860	10,660	12,480	530	2,510	3,420	2.4	10.7	15.7	4.24	A+	4.25	791	2,607
			9	9	12	18	2,160	2,160	2,620	3,930	2,200	10,870	12,960	550	2,630	3,560	2.5	11.2	16.3	4.13	A+	4.25	791	2,607
			9	9	12	24	1,970	1,970	2,400	4,660	2,280	11,000	13,110	570	2,680	3,620	2.6	11.4	16.6	4.11	A+	4.25	791	2,607
9	9	18	18	1,950	1,950	3,550	3,550	2,240	11,000	13,110	560	2,680	3,620	2.6	11.4	16.6	4.11	A+	4.25	791	2,607			
9	9	18	24	1,780	1,780	3,240	4,200	2,320	11,000	13,590	580	2,680	3,760	2.7	11.4	17.2	4.11	A+	4.25	791	2,607			
9	12	12	12	2,320	2,810	2,810	2,810	1,890	10,750	12,480	540	2,600	3,430	2.5	11.1	15.7	4.13	A+	4.25	791	2,607			
9	12	12	18	2,100	2,540	2,540	3,820	2,200	11,000	12,960	550	2,680	3,570	2.5	11.4	16.3	4.11	A+	4.25	791	2,607			
9	12	12	24	1,910	2,300	2,300	4,490	2,280	11,000	13,110	570	2,680	3,630	2.6	11.4	16.6	4.11	A+	4.25	791	2,607			
9	12	18	18	1,880	2,280	3,420	3,420	2,280	11,000	13,110	570	2,680	3,620	2.6	11.4	16.6	4.11	A+	4.25	791	2,607			
12	12	12	12	2,700	2,700	2,700	2,700	2,160	10,800	12,800	540	2,610	3,510	2.5	11.1	16.1	4.14	A+	4.25	791	2,607			
12	12	12	18	2,440	2,440	2,440	3,680	2,240	11,000	12,960	560	2,680	3,570	2.6	11.4	16.3	4.11	A+	4.25	791	2,607			
12	12	12	24	2,220	2,220	2,220	4,340	2,320	11,000	13,430	580	2,680	3,720	2.7	11.4	17.0	4.11	A+	4.25	791	2,607			
12	12	18	18	2,200	2,200	3,300	3,300	2,280	11,000	13,430	570	2,680	3,710	2.6	11.4	17.0	4.11	A+	4.25	791	2,607			













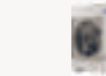

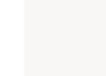

Outdoor Unit	A	B	C	D	E	Heating Capacity					Capacity			Power Consumption			Current			Effic. NOM. Heating at 7 °C/ 20 °C COP ¹	Seasonal Efficiency (According to EN14825) Class	SCOP	P design kW	Qhe kWh		
						W					W			W			A									
						A	B	C	D	E	MIN	STD	MAX	MIN	STD	MAX	MIN	STD	MAX						MIN	STD
AJ100TXJ5KG	5	Unit	7	7	7	7	7	2,200	2,200	2,200	2,200	2,200	1,650	11,000	13,110	550	2,560	3,610	2.5	11.7	16.5	4.30	A+	4.25	791	2,607
			7	7	7	7	9	2,080	2,080	2,080	3,120	1,820	11,440	12,960	550	2,670	3,570	2.5	12.2	16.3	4.28	A+	4.25	791	2,607	
			7	7	7	7	12	1,990	1,990	1,990	3,620	1,850	11,580	13,110	560	2,720	3,610	2.6	12.4	16.5	4.26	A+	4.25	791	2,607	
			7	7	7	7	18	1,710	1,710	1,710	4,660	2,000	11,500	13,430	570	2,700	3,710	2.6	12.3	17.0	4.26	A+	4.25	791	2,607	
			7	7	7	7	24	1,580	1,580	1,580	5,610	2,360	11,930	13,750	590	2,810	3,810	2.7	12.8	17.4	4.24	A+	4.25	791	2,607	
			7	7	7	9	9	1,950	1,950	2,930	2,930	1,930	11,710	13,430	550	2,750	3,690	2.5	12.5	16.9	4.26	A+	4.25	791	2,607	
			7	7	7	9	12	1,880	1,880	2,820	3,420	1,960	11,880	13,110	560	2,800	3,610	2.6	12.3	16.5	4.24	A+	4.25	791	2,607	
			7	7	7	9	18	1,630	1,630	2,440	4,450	2,280	11,780	13,590	570	2,790	3,750	2.6	12.7	17.2	4.22	A+	4.25	791	2,607	
			7	7	7	9	24	1,490	1,490	2,240	5,290	2,360	12,000	13,900	590	2,820	3,860	2.7	12.8	17.7	4.26	A+	4.25	791	2,607	
			7	7	7	12	12	1,730	1,730	3,140	3,140	1,960	11,470	13,430	560	2,680	3,700	2.6	12.2	16.9	4.28	A+	4.25	791	2,607	
			7	7	7	12	18	1,490	1,490	2,540	3,080	2,320	11,940	13,750	580	2,830										

Commercial



Line-up

CAC R32

Type		2.6 kW	3.5 kW	5.2 kW	7.1 kW	10 kW	12 kW	14 kW
								
360 Cassette					•	•	•	•
Wind-Free™ 4-Way Cassette				•	•	•	•	•
Wind-Free™ Mini 4-Way Cassette		•	•	•	•			
Wind-Free™ 1-Way Cassette		•	•					
Triangle Wall-Mounted		•	•	•	•			
Max Wall-Mounted						•		
LSP Duct		•	•	•	•			
MSP Duct			•	•	•	•	•	•
Console		•	•	•				
Ceiling				•	•	•	•	•

CAC R410A

Type		10 kW	14 kW	20 kW	25 kW
					
HSP Duct				•	•
Floor-Standing		•	•		

CAC R410A High Efficiency

Type		2.6 kW	3.5 kW	7.1 kW	10 kW	12 kW
						
4-Way Cassette				•	•	•
Mini 4-Way Cassette		•	•			
Triangle Wall-Mounted		•	•	•		
Max Wall-Mounted					•	
MSP Duct			•	•	•	•

Selection guide



Model	360 Cassette	Wind-Free™ Mini 4-Way Cassette	Wind-Free™ 4-Way Cassette	Wind-Free™ 1-Way Cassette	4-Way Cassette
Airflow	Wind-Free™ Cooling	•	•	•	•
	360 Degree Air Supply	•			
Air Purification	SPI Ioniser	Optional	Optional	Optional	Optional
	Long-life Filter				
Functions	Samsung SmartThings	Optional	Optional	Optional	Optional
	Wi-Fi Kit Compatibility	Optional	Optional	Optional	Optional
	Humidity Sensor		•	•	•
	MDS (Motion Detect Sensor)		Optional	Optional	
Operating Mode	Quiet				
Controls	Remote Controller Included				
Others	Drain Pump Included	•	•	•	•



Model	Mini 4-Way Cassette	LSP Duct	MSP Duct	HSP Duct
Airflow	Wind-Free™ Cooling			
	360 Degree Air Supply			
Air Purification	SPI Ioniser	Optional		
	Long-life Filter			
Functions	Samsung SmartThings	Optional	Optional	Optional
	Wi-Fi Kit Compatibility	Optional	Optional	Optional
	Humidity Sensor	•		
	MDS (Motion Detect Sensor)			
Operating Mode	Quiet			
Controls	Remote Controller Included			
Others	Drain Pump Included	Optional	Optional	Optional



Model	Triangle Wall-Mounted	Max Wall-Mounted	Console	Ceiling	Floor-Standing
Airflow	Wind-Free™ Cooling				
	360 Degree Air Supply				
Air Purification	SPI Ioniser		•		
	Long-life Filter	•	•	•	•
Functions	Samsung SmartThings	Optional	Optional	Optional	Optional
	Wi-Fi Kit Compatibility	Optional	Optional	Optional	Optional
	Humidity Sensor				
	MDS (Motion Detect Sensor)				
Operating Mode	Quiet				•
Controls	Remote Controller Included	•	•		
Others	Drain Pump Included				



Nomenclature

Commercial - Indoor units

AC 120 R N 4 P K H EU

1 2 3 4 5 6 7 8

1	Classification	AC	Commercial Air Conditioner (CAC)
2	Capacity	x1/10 kW (3 digits)	
3	Year	H	2014
		J	2015
		K	2016
		M	2017
		N	2018
		R	2019
		T	2020
4	Product Type	N	Indoor Unit (NASA)
5	Product Notation	1	Wind-Free™ 1-Way Cassette
		N	Wind-Free™ Mini 4-Way Cassette
		4	360 Cassette, Wind-Free™ 4-Way Cassette, 4-Way Cassette
		L	LSP Duct
		M	MSP Duct
		C	Ceiling
		J	Console
		P	Floor-Standing
		A	Triangle Wall-Mounted
		T	Max Wall-Mounted
		6	Feature
S	Standard		
D	Deluxe		
P	Premium		
7	Voltage Rating	K	1Φ, 220-240 V, 50 Hz
		N	3Φ, 380-415 V, 50 Hz
8	Mode	H	Heat Pump

Commercial - Outdoor units

AC 120 R X A D K H EU

1 2 3 4 5 6 7 8

1	Classification	AC	Commercial Air Conditioner (CAC)
2	Capacity	x1000 Btu/h (3 digits)	
3	Year	H	2014
		J	2015
		K	2016
		M	2017
		N	2018
		R	2019
		T	2020
4	Product Type	X	Outdoor Unit (NASA)
5	Feature 1	A	Inverter + Side + General Temperature
		S	Inverter + Side + Low Temperature
6	Feature 2	C	Deluxe + Low Temperature
		D	Deluxe
		P	Premium
7	Voltage Rating	E	1Φ, 220-240 V, 50 Hz
		G	3Φ, 380-415 V, 50 Hz
		K	1Φ, 220-240 V, 50/60 Hz
		N	3Φ, 380-415 V, 50/60 Hz
8	Mode	G	Heat Pump (R32)
		H	Heat Pump (R410A)

Twin/Triple/Quad combinations

CAC 

Indoor Unit	kW	Outdoor Unit			
		AC071RXADKG/EU 7	AC100RXADKG/EU AC100RXADNG/EU 10	AC120RXADKG/EU AC120RXADNG/EU 12	AC140RXADKG/EU AC140RXADNG/EU 14
360 Cassette 	7.0				2
	10.0				
	12.0				
Wind-Free™ 4-Way Cassette 	5.0		2	3	3
	7.0				2
	10.0				
Wind-Free™ 4-Way Mini Cassette 	3.5	2	3	4	4
	5.0		2	3	3
	7.0				2
Wind-Free™ 1-Way Cassette 	3.5	2	3	4	4
Triangle Wall-Mounted 	3.5	2	3	4	4
	5.0		2	3	3
	7.0				2
LSP Duct 	3.5	2	3	4	4
	5.0		2	3	3
	7.0				2
MSP Duct 	3.5	2	3	4	4
	5.0		2	3	3
	7.0				2
	10.0				
Console 	3.5	2	3	4	4
	5.0		2	3	3
Ceiling 	5.0		2	3	3
	7.0				2
	10.0				
	12.0				



Commercial

Commercial

Specifications

360 Cassette R32

- 360° air supply.
- Bladeless discharge thanks to three small booster fans.
- Built-in condensation drain pump (750 mmH2O).

- High ceiling mode for heights up to 4.6 m (12.8/14.0 kW), 3.9 m (11.2 kW), 3.5 m (4.5~9.0 kW).
- SPI Ioniser (optional).
- Circular or square cassette panel.



Indoor Unit		AC071RN4PKG/EU	AC100RN4PKG/EU	AC120RN4PKG/EU	AC140RN4PKG/EU	
Outdoor Unit - Mono-Phase		AC071RXADKG/EU	AC100RXADKG/EU	AC120RXADKG/EU	AC140RXADKG/EU	
Outdoor Unit - Tri-Phase		-	AC100RXADNG/EU	AC120RXADNG/EU	AC140RXADNG/EU	
Capacity						
Cooling (Min/Nominal/Max)	kW	1.50/7.10/8.70	3.00/10.00/12.00	3.50/12.00/13.50	3.50/13.40/15.50	
	Heating @ +7 °C (Min/Nominal/Max)	1.90/8.00/9.00	2.20/11.20/15.50	3.50/13.20/15.50	3.50/15.50/18.00	
	Heating @ -5 °C	7.80	11.00	12.90	15.20	
	Heating @ -15 °C	7.00	9.70	11.50	13.50	
Performance						
Energy Efficiency Cooling	SEER ¹	6.7 A++	6.8 A++	6.0 A+	6.4	
	Power Consumption	kWh/a	371	515	TBA	-
	Pdesignc	kW	7.1	10.0	TBA	-
	EER	W/W	2.60	3.08	2.69	2.81
Energy Efficiency Heating	SCOP ¹	4.2 A+	4.3 A+	4.0 A+	4.1	
	Power Consumption	kWh/a	1,500	1,726	TBA	-
	Pdesignh (average)	kW	4.5	5.3	6.5	8.4
	COP ¹	W/W	3.23	3.50	3.26	3.35
Airflow Rate	Indoor Unit (H/M/L)	m ³ /min	51.0	72.0	72.0	110.0
Sound Power	Indoor Unit	dB(A)	53	61	61	61
	Outdoor Unit	dB(A)	65	69	70	69
Sound Pressure	Indoor Unit (H/M/L)	dB(A)	36/33/29	44/39/33	45/40/35	45/41/37
	Outdoor Unit (H/L)	dB(A)	51/49	54/52	56/54	54/53
Fan/Outdoor Unit	Type		Turbo	Turbo	Turbo	Turbo
	Power	W	65	97	97	97
	Number of Fans	-	1	1	1	1
External Static Pressure	Min/Std/Max	Pa				
Operating Temperature Range	Cooling	°C	-15~50	-15~50	-15~50	-15~50
	Heating	°C	-20.0~24.0	-20.0~24.0	-20.0~24.0	-20.0~24.0
Electrical Data						
Power Source	Indoor Unit	Φ, #, V, Hz	1Φ, 2, 220~240 V, 50 Hz	1Φ, 2, 220~240 V, 50 Hz	1Φ, 2, 220~240 V, 50 Hz	1Φ, 2, 220~240 V, 50 Hz
	Outdoor Unit Mono-Phase	Φ, #, V, Hz	1Φ, 2, 220~240 V, 50 Hz	1Φ, 2, 220~240 V, 50 Hz	1Φ, 2, 220~240 V, 50 Hz	1Φ, 2, 220~240 V, 50 Hz
	Outdoor Unit Tri-Phase	Φ, #, V, Hz	-	3Φ, 4, 380~415 V, 50 Hz	3Φ, 4, 380~415 V, 50 Hz	3Φ, 4, 380~415 V, 50 Hz
Compressor Type	Outdoor Unit	Type	Twin BLDC	Twin BLDC	Twin BLDC	Twin BLDC
Power (Min/Nominal/Max)	Cooling	kW	0.35/2.73/3.60	0.60/3.24/4.70	0.90/4.45/5.30	0.80/4.76/6.45
	Heating	kW	0.35/2.48/3.95	0.46/3.20/5.40	0.75/4.05/5.60	0.70/4.62/7.36
Current Input	Cooling (Min/Std/Max)	A	2.00/11.80/16.00	3.00/14.40/20.40	0.75/4.05/5.60	3.70/20.60/28.00
	Heating (Min/Std/Max)	A	2.0/10.7/17.0	3.0/14.4/20.4	3.7/17.7/26.0	3.7/20.6/28.0
	Cooling - Tri-Phase (Min/Std/Max)	A	-	1.5/5.1/7.1	2.1/6.9/10.0	2.1/7.3/10.5
	Heating - Tri-Phase (Min/Std/Max)	A	-	1.2/5.0/8.4	2.1/6.3/12.0	1.9/7.1/12.0
Dimensions						
Net Dimensions (W x H x D)	Indoor Unit	mm	947 x 281 x 947	947 x 365 x 947	947 x 365 x 947	947 x 365 x 947
	Outdoor Unit	mm	880 x 798 x 310	940 x 998 x 330	940 x 998 x 330	940 x 1,210 x 330

Indoor Unit		AC071RN4PKG/EU	AC100RN4PKG/EU	AC120RN4PKG/EU	AC140RN4PKG/EU	
Outdoor Unit - Mono-Phase		AC071RXADKG/EU	AC100RXADKG/EU	AC120RXADKG/EU	AC140RXADKG/EU	
Outdoor Unit - Tri-Phase		-	AC100RXADNG/EU	AC120RXADNG/EU	AC140RXADNG/EU	
Net Weight	Indoor Unit	kg	20.2	23.5	23.5	25.5
	Outdoor Unit	kg	51.0	75.0	81.0	91.5
Refrigerant						
Refrigerant	Type	R32 (contains fluorinated greenhouse gases. GWP = 675)				
	Factory Charging	kg	1.7/15 m	2.7/30 m	2.7/30 m	2.9/30 m
	Charging Ton Equivalent CO ₂	tCO ₂ e	1.15	1.82	1.82	1.96
	Additional Refrigerant Charging	g/m	25	50	50	50
Piping Connections	Liquid Pipe	ø, inch	1/4	3/8	3/8	3/8
	Gas Pipe	ø, inch	5/8	5/8	5/8	5/8
Piping Length	Min/Max	m	3/50	50	50	75
Piping Height	Max	m	30	30	30	30
Piping Connections	Drain Pipe	ø, mm	VP25 (OD 32, ID 25)	VP25 (OD 32, ID 25)	VP25 (OD 32, ID 25)	VP25 (OD 32, ID 25)
Others						
Panel	Model Code		PC4NUNMAN	PC4NUNMAN	PC4NUNMAN	PC4NUNMAN
	Net Dimensions (W x H x D)	mm	1,050 x 66 x 1,050	1,050 x 66 x 1,050	1,050 x 66 x 1,050	1,050 x 66 x 1,050
	Net Weight	kg	2.7	2.7	2.7	2.7
Accessories	Drain Pump		Included	Included	Included	Included
	Max. Lifting Height/Displacement	mm / litres/h	750/24	750/24	750/24	750/24

Accessories										
AR-KH03E	MWR-SH00N	MWR-SH11N	MWR-WG00JN/MWR-WG00KN	MIM-H04EN	MRW-TA	PC4NUNMAN	PC4NUNMAN	PC4NUNMAN	PC4NUNMAN	MSD-CAN1

¹Energy labels as shown are according to EU No 626/2011 (LOT 10) label classification 2019, on a scale from D to A+++.

Dimensional drawings

360 Cassette (square)

AC071*N4PK*/EU

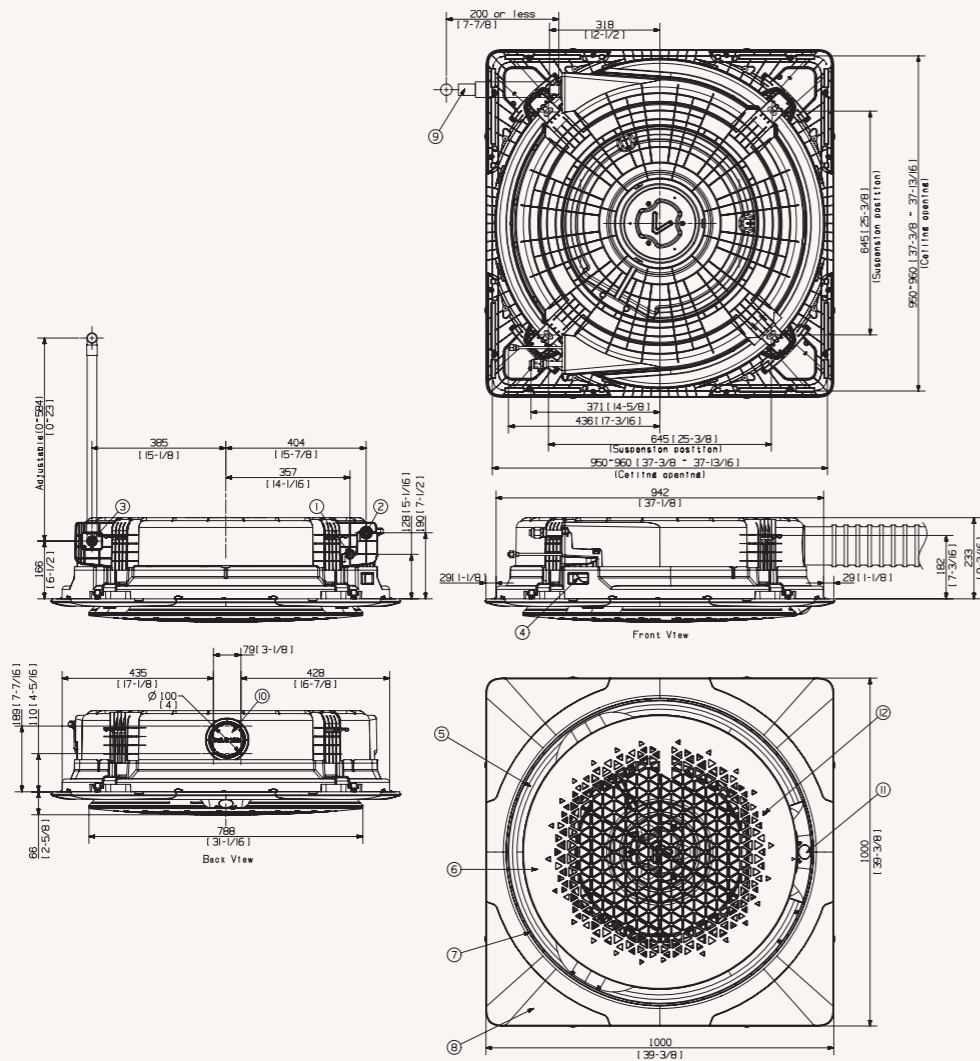

NO	Name	Description
1	Liquid piping	ø6.35 (1/4)
2	Gas piping	ø15.88 (5/8)
3	Condensation drain piping	VP25 (OD 32, ID 25)
4	Power supply/communication wiring conduits	
5	Air supply	
6	Air intake	
7	Booster Fan hollow space	
8	Panel	
9	Condensation drain piping (accessory)	
10	Knock-out hole - external air	ø100 mm
11	Display	
12	Wireless remote controller receiver	

AC090/100/120/140*N4PK*/EU

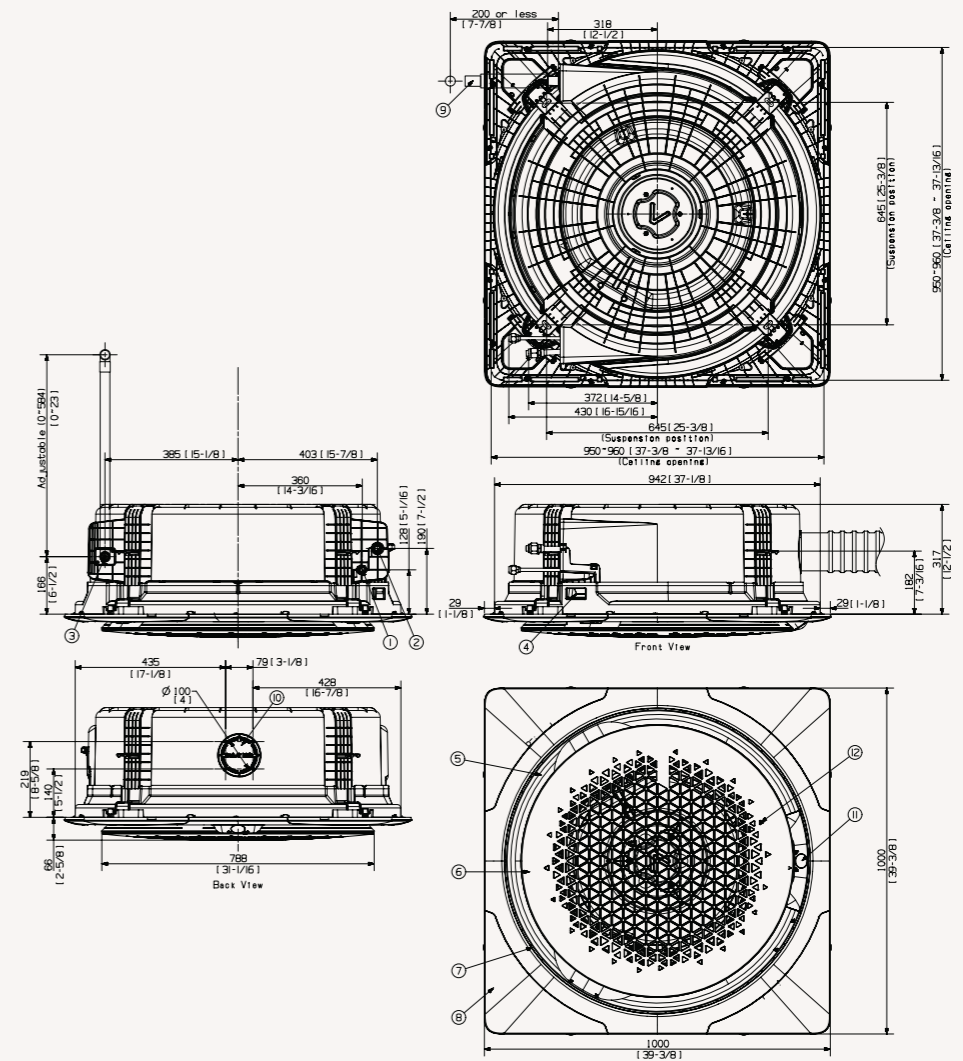

NO	Name	Description
1	Liquid piping	ø9.52 (3/8)
2	Gas piping	ø15.88 (5/8)
3	Condensation drain piping	VP25 (OD 32, ID 25)
4	Power supply/communication wiring conduits	
5	Air supply	
6	Air intake	
7	Booster Fan hollow space	
8	Panel	
9	Condensation drain piping (accessory)	
10	Knock-out hole - external air	ø100 mm
11	Display	
12	Wireless remote controller receiver	

Dimensional drawings

360 Cassette (circle)

AC071*N4PK*/EU

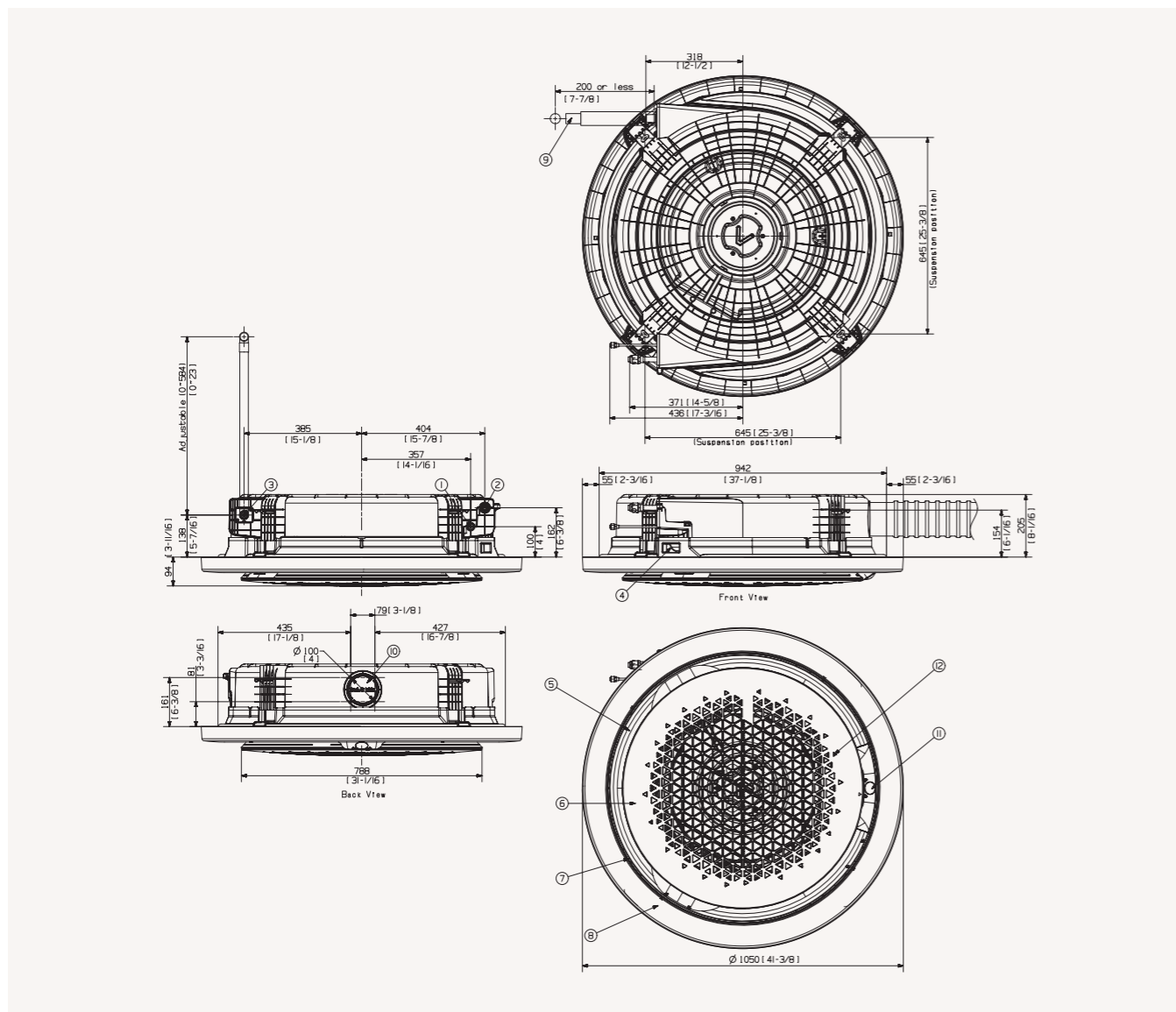

NO	Name	Description
1	Liquid piping	ø6.35 (1/4)
2	Gas piping	ø15.88 (5/8)
3	Condensation drain piping	VP25 (OD 32, ID 25)
4	Power supply/communication wiring conduits	
5	Air supply	
6	Air intake	
7	Booster Fan hollow space	
8	Panel	
9	Condensation drain piping (accessory)	
10	Knock-out hole - external air	ø100 mm
11	Display	
12	Wireless remote controller receiver	

AC090/100/120/140*N4PK*/EU

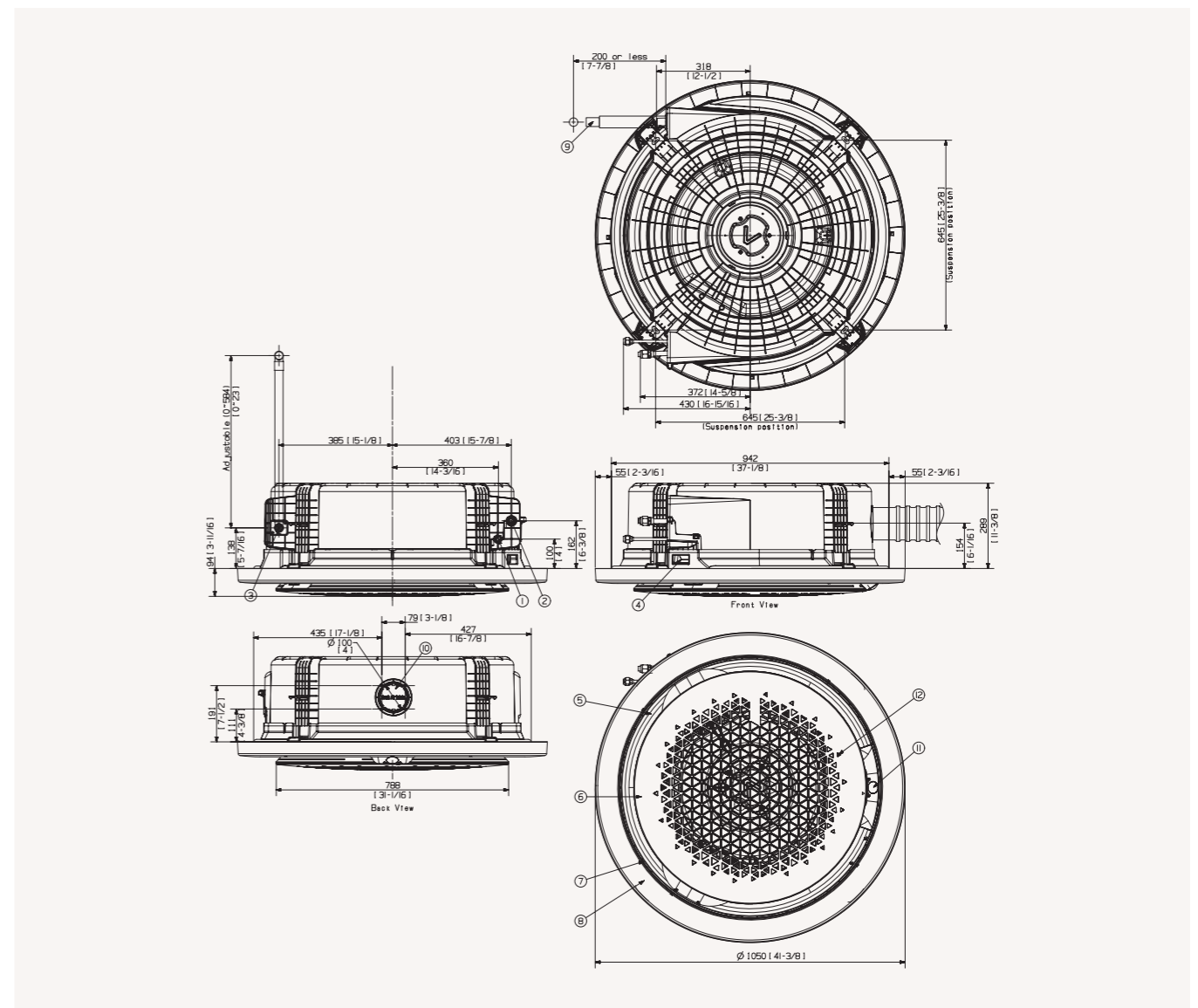

NO	Name	Description
1	Liquid piping	ø9.52 (3/8)
2	Gas piping	ø15.88 (5/8)
3	Condensation drain piping	VP25 (OD 32, ID 25)
4	Power supply/communication wiring conduits	
5	Air supply	
6	Air intake	
7	Booster Fan hollow space	
8	Panel	
9	Condensation drain piping (accessory)	
10	Knock-out hole - external air	ø100 mm
11	Display	
12	Wireless remote controller receiver	

Specifications

Wind-Free™ Mini 4-Way Cassette R32

- 2-Step Cooling: Fast Cooling & Wind-Free™ Cooling.
- Four-way air supply via independently adjustable blades.
- Blade angle between 32° and 75°; blade width 66 mm.
- Built-in humidity sensor.
- Built-in condensation drain pump (750 mmH₂O).



Indoor Unit		AC026RNNDKG/EU	AC035RNNDKG/EU	AC052RNNDKG/EU	AC071RNNDKG/EU	
Outdoor Unit - Mono-Phase		AC026RXADKG/EU	AC035RXADKG/EU	AC052RXADKG/EU	AC071RXADKG/EU	
Outdoor Unit - Tri-Phase						
Capacity						
Cooling (Min/Nominal/Max)	kW	0.87/2.60/4.10	0.88/3.50/4.50	1.30/5.00/6.20	1.50/6.80/8.30	
	Heating @ +7 °C (Min/Nominal/Max)	0.98/3.40/4.10	1.00/4.00/4.80	1.30/5.50/7.50	1.90/7.50/9.00	
	Heating @ -5 °C	3.3	3.9	5.4	7.4	
	Heating @ -15 °C	3.00	3.50	4.80	6.50	
Performance						
Energy Efficiency Cooling	SEER ¹	7.1/ A++	7.0/ A++	6.7/ A++	6.1/ A++	
	Power Consumption	128	175	261	390	
	Pdesignc	2.6	3.5	5.0	6.8	
	EER	3.88	3.40	3.27	2.47	
Energy Efficiency Heating	SCOP ¹	4.3/ A+	4.3/ A+	4.2/ A+	3.8/ A	
	Power Consumption	684	684	800	1,474	
	Pdesignh (average)	2.1	2.1	2.4	4.0	
	COP ¹	3.69	3.33	3.62	2.68	
Airflow Rate	Indoor Unit (H/M/L)	m ³ /min	30.0	30.0	40.0	51.0
Sound Power	Indoor Unit	dB(A)	48	50	56	58
	Outdoor Unit	dB(A)	59	61	62	65
Sound Pressure	Indoor Unit (H/M/L)	dB(A)	31/28/25	34/30/25	39/34/29	42/39/36
	Outdoor Unit (H/L)	dB(A)	47/46	48/48	48/48	51/49
Fan/Outdoor Unit	Type		Turbo	Turbo	Turbo	Turbo
	Power	W	65	65	65	65
	Number of Fans	-	1	1	1	1
External Static Pressure	Min/Std/Max	Pa				
Operating Temperature Range	Cooling	°C	-15~46	-15~46	-15~50	-15~50
	Heating	°C	-20.0~24.0	-20.0~24.0	-20.0~24.0	-20.0~24.0
Electrical Data						
Power Source	Indoor Unit	Φ, #, V, Hz	1Φ, 2, 220~240 V, 50 Hz	1Φ, 2, 220~240 V, 50 Hz	1Φ, 2, 220~240 V, 50 Hz	1Φ, 2, 220~240 V, 50 Hz
	Outdoor Unit Mono-Phase	Φ, #, V, Hz	1Φ, 2, 220~240 V, 50 Hz	1Φ, 2, 220~240 V, 50 Hz	1Φ, 2, 220~240 V, 50 Hz	1Φ, 2, 220~240 V, 50 Hz
	Outdoor Unit Tri-Phase	Φ, #, V, Hz				
Compressor Type	Outdoor Unit	Type	Single BLDC	Single BLDC	Twin BLDC	Twin BLDC
Power (Min/Nominal/Max)	Cooling	kW	0.16/0.67/1.20	0.18/1.03/1.40	0.31/1.53/2.10	0.35/2.75/3.60
	Heating	kW	0.20/0.92/1.45	0.19/1.20/1.80	0.35/1.52/2.40	0.35/2.80/3.95
Current Input	Cooling (Min/Std/Max)	A	1.3/3.5/5.5	1.4/5.0/6.0	2.6/7.0/9.5	2.0/12.0/16.0
	Heating (Min/Std/Max)	A	1.3/4.6/7.0	1.3/5.7/10.5	2.9/7.0/11.0	2.0/12.0/17.0
	Cooling - Tri-Phase (Min/Std/Max)	A				
	Heating - Tri-Phase (Min/Std/Max)	A				
Dimensions						
Net Dimensions (W x H x D)	Indoor Unit	mm	575 x 250 x 575	575 x 250 x 575	575 x 250 x 575	575 x 250 x 575
	Outdoor Unit	mm	790 x 548 x 285	790 x 548 x 285	880 x 638 x 310	880 x 798 x 310
Net Weight	Indoor Unit	kg	11.5	11.5	12.0	12.0
	Outdoor Unit	kg	32.5	32.5	43.0	51.0
Refrigerant						



Indoor Unit		AC026RNNDKG/EU	AC035RNNDKG/EU	AC052RNNDKG/EU	AC071RNNDKG/EU	
Outdoor Unit - Mono-Phase		AC026RXADKG/EU	AC035RXADKG/EU	AC052RXADKG/EU	AC071RXADKG/EU	
Outdoor Unit - Tri-Phase						
Refrigerant	Type	R32 (contains fluorinated greenhouse gases. GWP = 675)				
	Factory Charging	kg	0.9/20 m	0.9/20 m	1.2/10 m	1.7/15 m
	Charging Ton equivalent CO ₂	tCO ₂ e	0.61	0.61	0.81	1.15
	Additional Refrigerant Charging	g/m	-	-	15	25
Piping Connections	Liquid Pipe	ø, inch	1/4	1/4	1/4	1/4
	Gas Pipe	ø, inch	3/8	3/8	1/2	5/8
Piping Length	Min/Max	m	3/20	3/20	3/30	3/50
Piping Height	Max	m	15	15	20	30
Piping Connections	Drain Pipe	ø, mm	ID 18	ID 18	ID 18	ID 18
Others						
Panel	Model Code		PC4SUFMAN	PC4SUFMAN	PC4SUFMAN	PC4SUFMAN
	Net Dimensions (W x H x D)	mm	620 x 46 x 620	620 x 46 x 620	620 x 46 x 620	620 x 46 x 620
	Net Weight	kg	2.7	2.7	2.7	2.7
Accessories	Drain Pump		Included	Included	Included	Included
	Max. Lifting Height/Displacement	mm / litres/h	750/24	750/24	750/24	750/24

Accessories							
							
Wireless Remote Controller	Simple Type Controller	Touch Controller	Advanced Wired Controller	Panel (Mandatory)	External Thermostat	Wi-Fi Kit	SPI Ioniser
AR-EH03E	MWR-SH00N	MWR-SH11N	MWR-WG00JN/ MWR-WG00KN	PC4SUFMAN	MRW-TA	MIM-H04EN	MSD-CAN1

¹Energy labels as shown are according to EU No 626/2011 (LOT 10) label classification 2019, on a scale from D to A+++.

Dimensional drawings

Wind-Free™ Mini 4-Way Cassette

AC026/035/052/060/071*NNDK*/EU

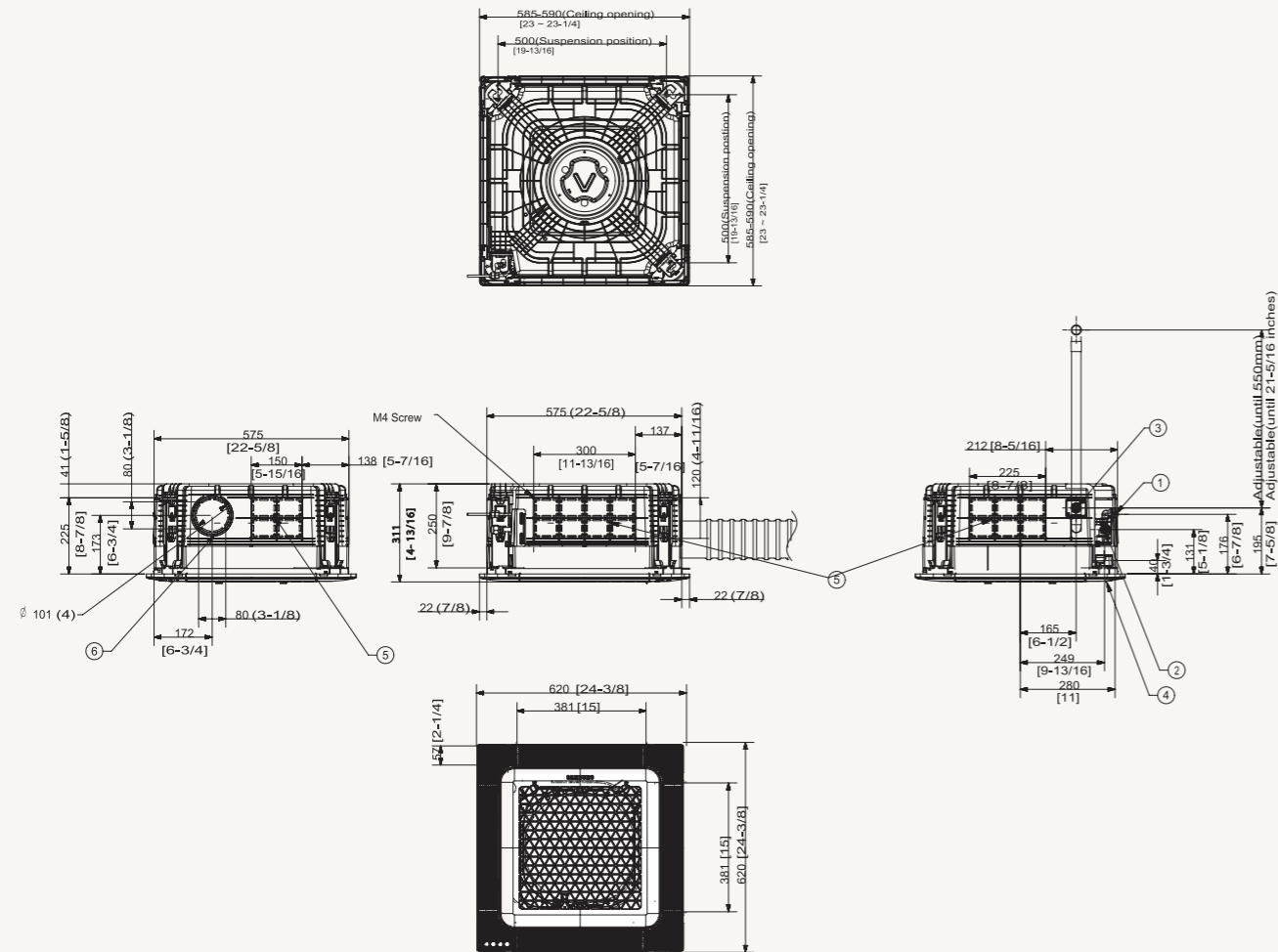

Specifications

Wind-Free™ 4-Way Cassette R32

- 2-Step Cooling: Fast Cooling & Wind-Free™ Cooling.
- Four-way air supply via independently adjustable blades.
- Blade angle between 34° and 68°; blade width 84 mm.
- Built-in humidity sensor.





- High ceiling mode for heights up to 4.6 m (12.0-14.0 kW), 3.9 m (9.0-10.0 kW), 3.5 m (5.2-7.1 kW).
- Built-in condensation drain pump (750 mmH2O).
- SPI Ioniser (optional).



Indoor Unit		AC052RN4DKG/EU	AC071RN4DKG/EU	AC100RN4DKG/EU	AC120RN4DKG/EU	AC140RN4DKG/EU	
Outdoor Unit - Mono-Phase		AC052RXADKG/EU	AC071RXADKG/EU	AC100RXADKG/EU	AC120RXADKG/EU	AC140RXADKG/EU	
Outdoor Unit - Tri-Phase		-	-	AC100RXADNG/EU	AC120RXADNG/EU	AC140RXADNG/EU	
Capacity							
Cooling (Min/Nominal/Max)	kW	1.00/5.00/6.50	1.50/7.10/8.70	3.00/10.00/12.00	3.50/12.00/13.50	3.50/13.40/15.00	
Heating @ +7 °C (Min/Nominal/Max)	kW	1.00/6.00/7.00	1.90/8.00/9.00	2.20/11.20/15.50	3.50/13.20/15.50	3.50/15.50/18.00	
Heating @ -5 °C	kW	5.90	7.80	11.00	12.90	15.20	
Heating @ -15 °C	kW	5.20	7.00	9.70	11.50	13.50	
Performance							
Energy Efficiency Cooling	SEER ¹	7.6/ A++	6.7/ A++	7.0/ A++	6.0/ A+	6.6/ A++	
Power Consumption	kWh/a	230	371	500	TBA	-	
Pdesignc	kW	5.0	7.1	10.0	TBA	-	
EER	W/W	3.50	2.98	2.92	2.60	3.16	
Energy Efficiency Heating	SCOP ¹	4.3/ A+	4.2/ A+	4.3/ A++	4.0/ A+	4.3/ A++	
Power Consumption	kWh/a	847	1,500	1,726	TBA	-	
Pdesignh (average)	kW	2.60	4.50	5.30	TBA	-	
COP ¹	W/W	4.03	3.27	3.61	3.18	3.16	
Airflow Rate	Indoor Unit (H/M/L)	m ³ /min	40.0	51.0	72.0	110.0	
Sound Power	Indoor Unit	dB(A)	49	53	61	61	
	Outdoor Unit	dB(A)	62	65	69	70	69
Sound Pressure	Indoor Unit (H/M/L)	dB(A)	33/31/29	36/33/29	44/39/33	45/40/35	45/41/37
	Outdoor Unit (H/L)	dB(A)	48/48	51/49	54/52	56/54	54/53
Fan/Outdoor Unit	Type		BLDC	BLDC	BLDC	BLDC	
	Power	W	65	65	97	97	
	Number of Fans	-	1	1	1	1	
External Static Pressure	Min/Std/Max	Pa					
Operating Temperature Range	Cooling	°C	-15-50	-15-50	-15-50	-15-50	
	Heating	°C	-20.0-24.0	-20.0-24.0	-20.0-24.0	-20.0-24.0	
Electrical Data							
Power Source	Indoor Unit	Φ, #, V, Hz	1Φ, 2, 220-240 V, 50 Hz	1Φ, 2, 220-240 V, 50 Hz	1Φ, 2, 220-240 V, 50 Hz	1Φ, 2, 220-240 V, 50 Hz	
	Outdoor Unit Mono-Phase	Φ, #, V, Hz	1Φ, 2, 220-240 V, 50 Hz	1Φ, 2, 220-240 V, 50 Hz	1Φ, 2, 220-240 V, 50 Hz	1Φ, 2, 220-240 V, 50 Hz	
	Outdoor Unit Tri-Phase	Φ, #, V, Hz	-	-	3Φ, 4, 380-415 V, 50 Hz	3Φ, 4, 380-415 V, 50 Hz	
Compressor Type	Outdoor Unit	Type	Twin BLDC	Twin BLDC	Twin BLDC	Twin BLDC	
Power (Min/Nominal/Max)	Cooling	kW	0.33/1.43/2.30	0.35/2.38/3.60	0.60/3.42/4.70	0.90/4.60/5.30	
	Heating	kW	0.25/1.49/2.50	0.35/2.45/3.95	0.46/3.10/5.40	0.75/4.15/5.60	
Current Input	Cooling (Min/Std/Max)	A	1.5/6.5/9.5	2.0/10.3/16.0	3.0/15.2/20.4	4.3/20.1/24.0	
	Heating (Min/Std/Max)	A	1.5/6.8/12.0	2.0/10.7/17.0	2.5/13.6/23.0	3.7/18.2/26.0	
	Cooling - Tri-Phase (Min/Std/Max)	A	-	-	1.5/5.5/7.1	2.1/6.8/10.0	
	Heating - Tri-Phase (Min/Std/Max)	A	-	-	1.2/5.1/8.4	2.1/6.3/12.0	
Dimensions							
Net Dimensions (W x H x D)	Indoor Unit	mm	840 x 204 x 840	840 x 204 x 840	840 x 204 x 840	840 x 204 x 840	
	Outdoor Unit	mm	880 x 638 x 310	880 x 798 x 310	940 x 998 x 330	940 x 998 x 330	
Net Weight	Indoor Unit	kg	14.5	14.5	14.5	18.0	
	Outdoor Unit	kg	43.0	51.0	75.0	81.0	
Refrigerant							



Indoor Unit		AC052RN4DKG/EU	AC071RN4DKG/EU	AC100RN4DKG/EU	AC120RN4DKG/EU	AC140RN4DKG/EU
Outdoor Unit - Mono-Phase		AC052RXADKG/EU	AC071RXADKG/EU	AC100RXADKG/EU	AC120RXADKG/EU	AC140RXADKG/EU
Outdoor Unit - Tri-Phase		-	-	AC100RXADNG/EU	AC120RXADNG/EU	AC140RXADNG/EU
Refrigerant	Type	R32 (contains fluorinated greenhouse gases. GWP = 675)				
	Factory Charging	kg	1.2/10 m	1.7/15 m	2.7/30 m	2.7/30 m
	Charging Ton equivalent CO ₂	tCO ₂ e	0.81	1.15	1.82	1.82
	Additional Refrigerant Charging	g/m	15	25	50	50
Piping Connections	Liquid Pipe	ø, inch	1/4	1/4	3/8	3/8
	Gas Pipe	ø, inch	1/2	5/8	5/8	5/8
Piping Length	Min/Max	m	3/30	3/50	50	75
	Max	m	20	30	30	30
Piping Connections	Drain Pipe	ø, mm	VP25 (OD 32, ID 25)	VP25 (OD 32, ID 25)	VP25 (OD 32, ID 25)	VP25 (OD 32, ID 25)
Others						
Panel	Model Code		PC4NUFMAN	PC4NUFMAN	PC4NUFMAN	PC4NUFMAN
	Net Dimensions (W x H x D)	mm	950 x 48 x 950	950 x 48 x 950	950 x 48 x 950	950 x 48 x 950
	Net Weight	kg	6.3	6.3	6.3	6.3
Accessories	Drain Pump		Included	Included	Included	Included
	Max. Lifting Height/Displacement	mm / litres/h	750/24	750/24	750/24	750/24

Accessories							
							
Wireless Remote Controller	Simple Type Controller	Touch Controller	Advanced Wired Controller	Panel (Mandatory)	External Thermostat	Wi-Fi Kit	SPI Ioniser
AR-EH03E	MWR-SH00N	MWR-SH11N	MWR-WG00JN/ MWR-WG00KN	PC4NUFMAN	MRW-TA	MIM-H04EN	MSD-CAN1

¹Energy labels as shown are according to EU No 626/2011 (LOT 10) label classification 2019, on a scale from D to A+++.

Specifications







Wind-Free™ 1-Way Cassette R32

- 2-Step Cooling: Fast Cooling & Wind-Free™ Cooling.
- Blade angle between 37° and 87°, blade width 100 mm.
- Built-in humidity sensor.
- Height of only 152 mm.
- Built-in condensation drain pump (750 mmH2O).



Indoor Unit		AC026RN1DKG/EU	AC035RN1DKG/EU
Outdoor Unit - Mono-Phase		AC026RXADKG/EU	AC035RXADKG/EU
Outdoor Unit - Tri-Phase			
Capacity			
Cooling (Min/Nominal/Max)	kW	0.82/2.60/3.80	0.85/3.50/4.20
Heating @ +7 °C (Min/Nominal/Max)	kW	0.98/3.30/4.40	1.00/4.00/5.00
Heating @ -5 °C	kW	3.2	3.9
Heating @ -15 °C	kW	2.9	2.8
Performance			
Energy Efficiency Cooling	SEER ¹	6.4/ A++	6.2/ A++
Power Consumption	kWh/a	142	198
Pdesignc	kW	2.60	3.50
EER	W/W	3.61	3.21
Energy Efficiency Heating	SCOP ¹	4.0/ A+	4.0/ A+
Power Consumption	kWh/a	700	700
Pdesignh (average)	kW	2.0	2.0
COP ¹	W/W	3.26	3.12
Airflow Rate	Indoor Unit (H/M/L)	m ³ /min	7.3/6.5/5.8
Sound Power	Indoor Unit	dB(A)	52
	Outdoor Unit	dB(A)	59
Sound Pressure	Indoor Unit (H/M/L/Silent)	dB(A)	32/29/26/25
	Outdoor Unit (H/L)	dB(A)	47/46
Fan/Outdoor Unit	Type		Crossflow Fan
	Power	W	27
	Number of Fans	-	1
External Static Pressure	Min/Std/Max	Pa	
Operating Temperature Range	Cooling	°C	-15-46
	Heating	°C	-20.0-24.0
Electrical Data			
Power Source	Indoor Unit	Φ, #, V, Hz	1Φ, 2, 220-240 V, 50 Hz
	Outdoor Unit Mono-Phase	Φ, #, V, Hz	1Φ, 2, 220-240 V, 50 Hz
	Outdoor Unit Tri-Phase	Φ, #, V, Hz	
Compressor Type	Outdoor Unit	Type	Single BLDC
Power (Min/Nominal/Max)	Cooling	kW	0.17/0.72/1.16
	Heating	kW	0.20/1.01/1.45
Current Input	Cooling (Min/Std/Max)	A	1.2/3.8/5.4
	Heating (Min/Std/Max)	A	1.4/5.0/7.0
	Cooling - Tri-Phase (Min/Std/Max)	A	
	Heating - Tri-Phase (Min/Std/Max)	A	
Dimensions			
Net Dimensions (W x H x D)	Indoor Unit	mm	970 x 135 x 410
	Outdoor Unit	mm	790 x 548 x 285
Net Weight	Indoor Unit	kg	9.2
	Outdoor Unit	kg	32.5

Indoor Unit		AC026RN1DKG/EU	AC035RN1DKG/EU
Outdoor Unit - Mono-Phase		AC026RXADKG/EU	AC035RXADKG/EU
Outdoor Unit - Tri-Phase			
Refrigerant			
Refrigerant	Type	R32 (contains fluorinated greenhouse gases. GWP = 675)	
	Factory Charging	kg	0.9/20 m
	Charging Ton equivalent CO ₂	tCO ₂ e	0.61
	Additional Refrigerant Charging	g/m	-
Piping Connections	Liquid Pipe	ø, inch	1/4
	Gas Pipe	ø, inch	3/8
Piping Length	Min/Max	m	3/20
Piping Height	Max	m	15
Piping Connections	Drain Pipe	ø, mm	ID 18
Others			
Panel	Model Code		PC1NWFMAN
	Net Dimensions (W x H x D)	mm	1,198 x 35 x 500
	Net Weight	kg	4.3
Accessories	Drain Pump		Included
	Max. Lifting Height/Displacement	mm / litres/h	750/24

Accessories						
						
Wireless Remote Controller	Simple Type Controller	Touch Controller	Advanced Wired Controller	Wi-Fi Kit	Panel (Mandatory)	External Thermostat
AR-EH03E	MWR-SH00N	MWR-SH11N	MWR-WG00JN/ MWR-WG00KN	MIM-H04EN	PC4NUNMAN	MRW-TA

¹Energy labels as shown are according to EU No 626/2011 (LOT 10) label classification 2019, on a scale from D to A+++.

Dimensional drawings

Wind-Free™ 1-Way Cassette

AC026/035MN1DKH/EU

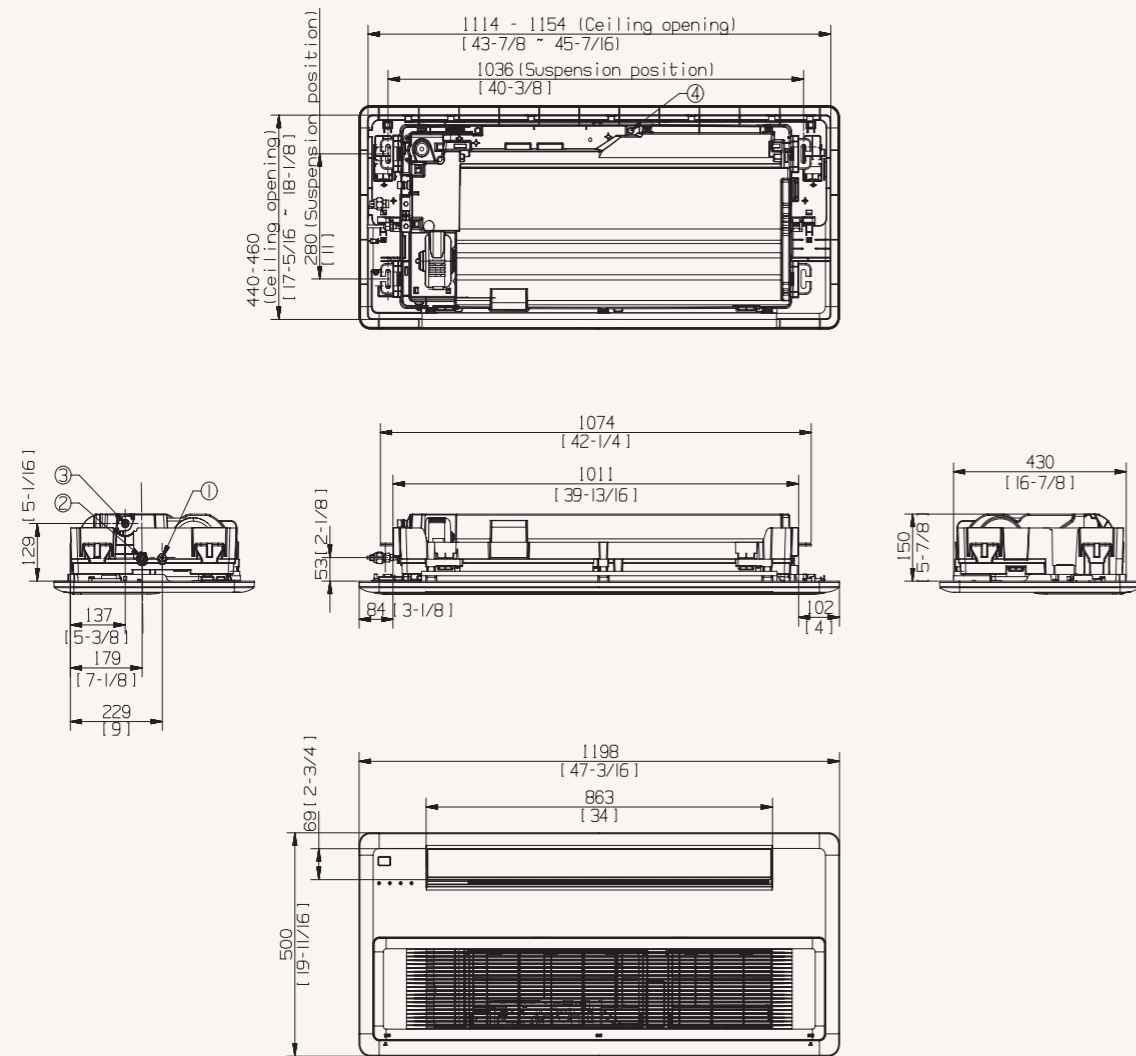

NO	Name	Description
1	Liquid pipe connection	ø6.35 (1/4)
2	Gas pipe connection	ø9.52 (3/8)
3	Drain pipe connection	VP20 (OD 26, ID 20)
4	Power supply/communication wiring conduits	



Specifications

LSP Duct R32

- Fan with inverter motor; prevalence adjustable up to 40 Pa; thickness of just 200.
- 750 mmH₂O condensation drain pump (optional); antibacterial filter included.



Indoor Unit		AC026RNLDKG/EU	AC035RNLDKG/EU	AC052RNLDKG/EU	AC071RNLDKG/EU	
Outdoor Unit - Mono-Phase		AC026RXADKG/EU	AC035RXADKG/EU	AC052RXADKG/EU	AC071RXADKG/EU	
Outdoor Unit - Tri-Phase						
Capacity						
Cooling (Min/Nominal/Max)	kW	0.80/2.60/3.80	0.85/3.50/4.30	1.20/5.00/6.50	1.50/7.10/8.70	
	Heating @ +7 °C (Min/Nominal/Max)	0.98/3.30/4.30	1.00/4.00/5.00	1.10/6.00/7.20	1.90/8.00/9.00	
	Heating @ -5 °C	3.2	3.9	5.9	7.8	
	Heating @ -15 °C	2.9	3.5	5.2	7.0	
Performance						
Energy Efficiency Cooling	SEER ¹	6.2/ A++	6.1/ A++	6.1/ A++	6.0/ A+	
	Power Consumption	147	201	287	414	
	Pdesignc	2.60	3.50	5.00	7.10	
	EER	3.82	3.12	2.96	2.98	
Energy Efficiency Heating	SCOP ¹	4.0/ A+	4.0/ A+	3.9/ A	3.9/ A	
	Power Consumption	700	700	862	1,328	
	Pdesignh (average)	2.0	2.0	2.4	3.7	
	COP ¹	3.79	3.31	3.45	3.36	
Airflow Rate	Indoor Unit (H/M/L)	m ³ /min	9.0/8.2/7.4	9.5/8.5/7.5	13.5/11.5/9.5	19.0/14.5/10.0
Sound Power	Indoor Unit	dB(A)	53	53	55	59
	Outdoor Unit	dB(A)	59	61	62	65
Sound Pressure	Indoor Unit (H/M/L)	dB(A)	32/29/26	33/30/27	33/30/27	37/32/27
	Outdoor Unit (H/L)	dB(A)	47/46	48/48	48/48	51/49
Fan/Outdoor Unit	Type		Sirocco	Sirocco	Sirocco	Sirocco
	Power	W	153	153	153	153
	Number of Fans	-	2	2	3	3
External Static Pressure	Min/Std/Max	Pa	0.00/25.00/39.00	0.00/25.00/39.00	0.00/25.00/39.00	0.00/25.00/39.00
Operating Temperature Range	Cooling	°C	-15-46	-15-46	-15-50	-15-50
	Heating	°C	-20.0-24.0	-20.0-24.0	-20.0-24.0	-20.0-24.0
Electrical Data						
Power Source	Indoor Unit	Φ, #, V, Hz	1Φ, 2, 220-240 V, 50 Hz	1Φ, 2, 220-240 V, 50 Hz	1Φ, 2, 220-240 V, 50 Hz	1Φ, 2, 220-240 V, 50 Hz
	Outdoor Unit Mono-Phase	Φ, #, V, Hz	1Φ, 2, 220-240 V, 50 Hz	1Φ, 2, 220-240 V, 50 Hz	1Φ, 2, 220-240 V, 50 Hz	1Φ, 2, 220-240 V, 50 Hz
	Outdoor Unit Tri-Phase	Φ, #, V, Hz				
Compressor Type	Outdoor Unit	Type	Single BLDC	Single BLDC	Twin BLDC	Twin BLDC
	Power (Min/Nominal/Max)	kW	0.19/0.68/1.20	0.20/1.12/1.40	0.35/1.69/2.20	0.35/2.38/3.60
Current Input	Heating	kW	0.20/0.87/1.45	0.19/1.21/1.80	0.26/1.74/2.70	0.35/2.38/3.95
	Cooling (Min/Std/Max)	A	1.5/3.6/5.5	1.6/5.4/6.5	2.1/7.7/10.0	2.0/10.5/16.0
	Heating (Min/Std/Max)	A	1.3/4.5/7.0	1.3/5.8/10.5	1.7/7.8/12.0	2.0/10.4/17.0
	Cooling - Tri-Phase (Min/Std/Max)	A				
Dimensions	Indoor Unit	mm	700 x 199 x 600	700 x 199 x 600	1,100 x 200 x 450	1,100 x 200 x 450
	Outdoor Unit	mm	790 x 548 x 285	790 x 548 x 285	880 x 638 x 310	880 x 798 x 310



Indoor Unit		AC026RNLDKG/EU	AC035RNLDKG/EU	AC052RNLDKG/EU	AC071RNLDKG/EU	
Outdoor Unit - Mono-Phase		AC026RXADKG/EU	AC035RXADKG/EU	AC052RXADKG/EU	AC071RXADKG/EU	
Outdoor Unit - Tri-Phase						
Net Weight	Indoor Unit	kg	19.0	19.0	23.5	23.5
	Outdoor Unit	kg	32.5	32.5	43.0	51.0
Refrigerant						
Refrigerant	Type	R32 (contains fluorinated greenhouse gases. GWP = 675)				
	Factory Charging	kg	0.9/20 m	0.9/20 m	1.2/10 m	1.7/15 m
	Charging Ton equivalent CO ₂	tCO ₂ e	0.61	0.61	0.81	1.15
	Additional Refrigerant Charging	g/m	-	-	15	25
Piping Connections	Liquid Pipe	ø, inch	1/4	1/4	1/4	1/4
	Gas Pipe	ø, inch	3/8	3/8	1/2	5/8
Piping Length	Min/Max	m	3/20	3/20	3/30	3/50
Piping Height	Max	m	15	15	20	30
Piping Connections	Drain Pipe	ø, mm	VP25 (OD 32, ID 25)	VP25 (OD 32, ID 25)	VP25 (OD 32, ID 25)	VP25 (OD 32, ID 25)
Others						
Panel	Model Code					
	Net Dimensions (W x H x D)	mm				
	Net Weight	kg				
Accessories	Drain Pump	MDP-E075SEE3D	MDP-E075SEE3D	MDP-G075SP	MDP-G075SP	
	Max. Lifting Height/Displacement	mm / litres/h	750/24	750/24	750/24	750/24

Accessories



Drain Pump (optional)	Wireless Remote Controller	Touch Controller	Advanced Wired Controller	Wi-Fi Kit	Wireless Receiver Kit	External Thermostat	SPI Ioniser
MDP-E075SEE3D	AR-EH03E (to be matched with MRK-A10N)	MWR-SH11N	MWR-WG00JN/ MWR-WG00KN	MIM-H04N	MRK-A10N (to be matched with AR-EH03E)	MRW-TA	MSD-EAN1

¹Energy labels as shown are according to EU No 626/2011 (LOT 10) label classification 2019, on a scale from D to A+++.

Dimensional drawings

LSP Duct

AC026/035*NLDK*/EU

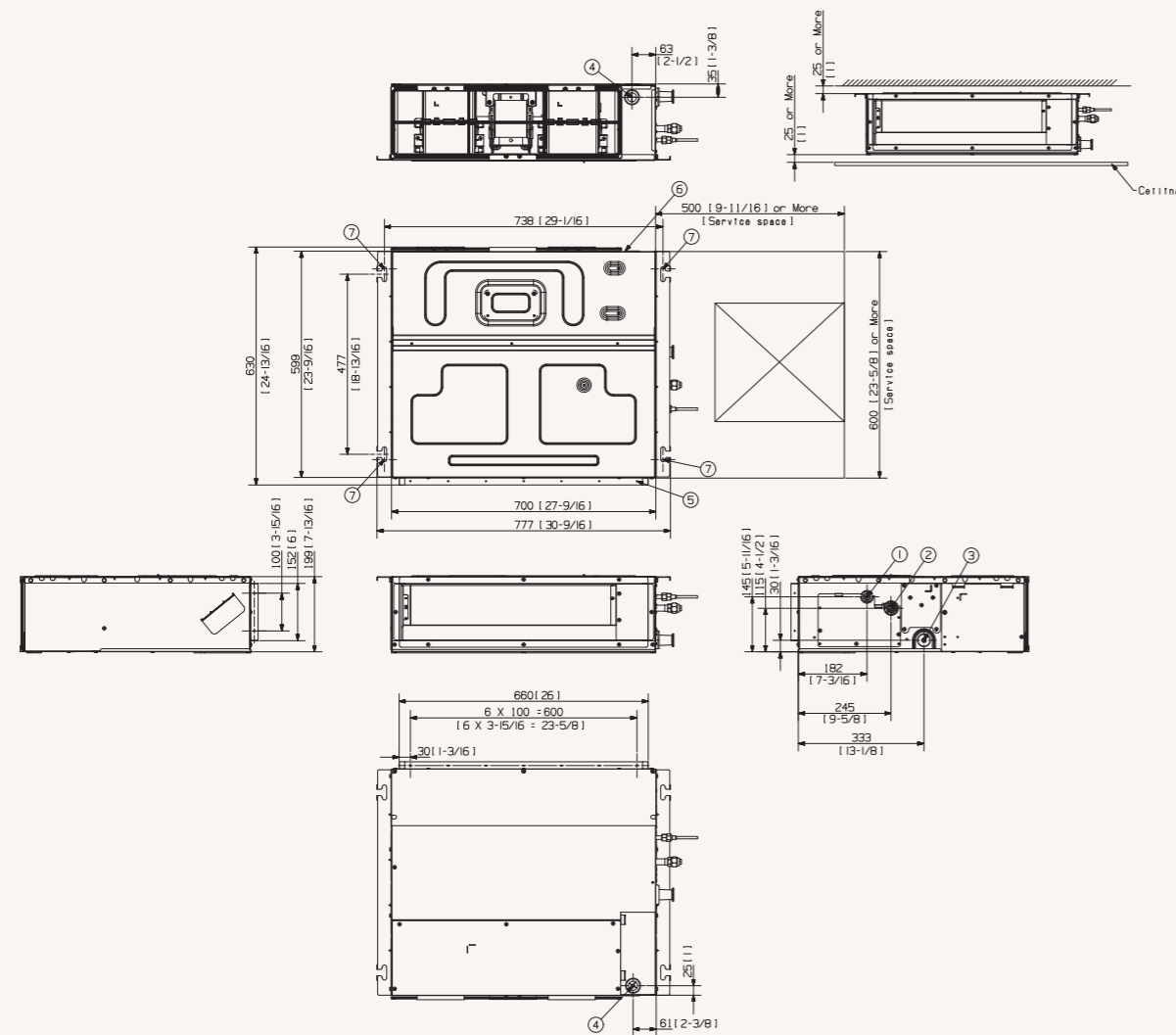

NO	Name	Description
1	Liquid piping	ø6.35 (1/4)
2	Gas piping	ø9.52 (3/8)
3	Condensation drain piping	VP25 (OD 32, ID 25)
4	Power supply/communication wiring conduits	
5	Air intake	
6	Air supply	
7	Air tie rods	Use M8-M10 bolt (4x)

AC052/071*NLDK*/EU

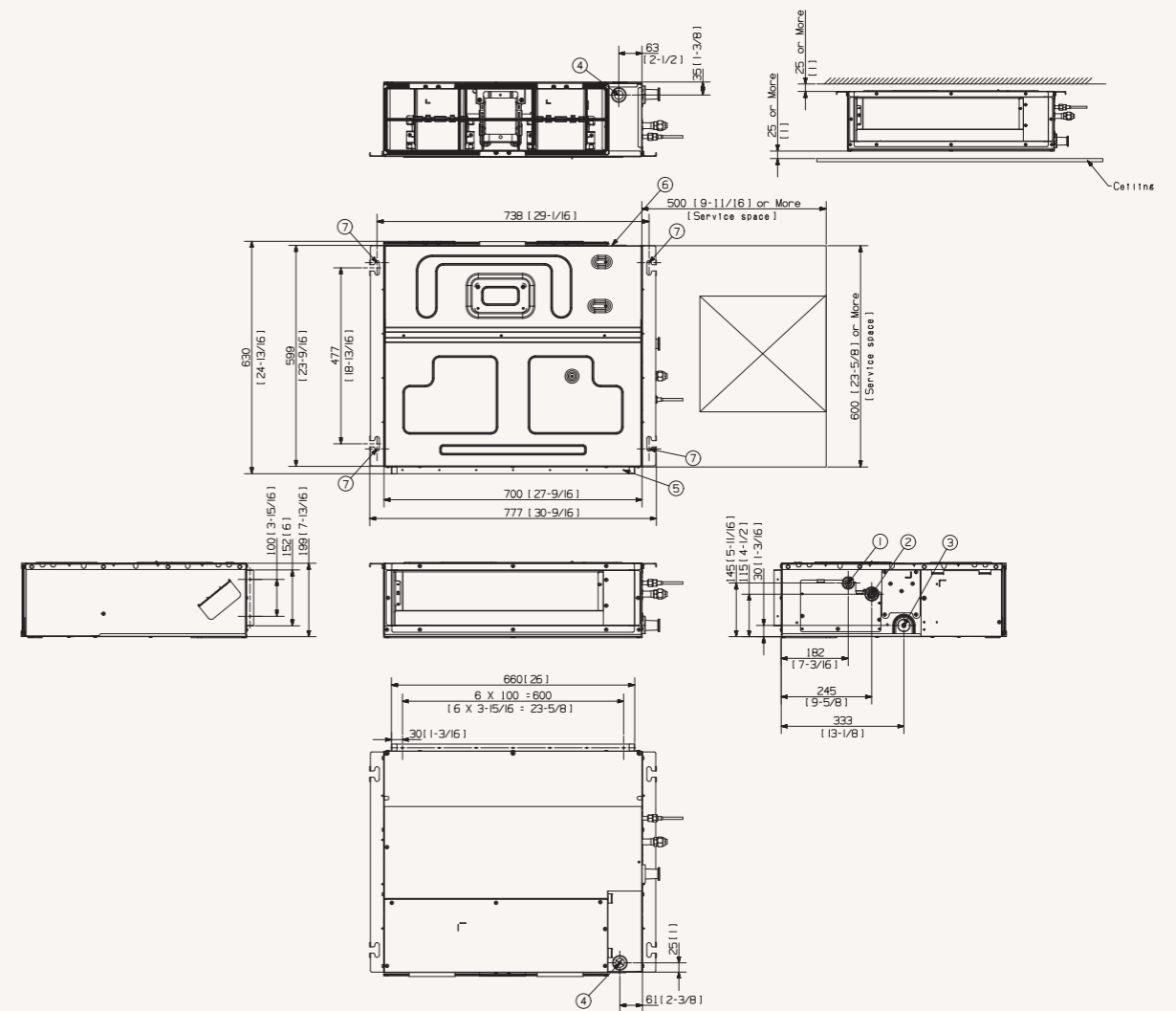

NO	Name	Description
1	Liquid piping	ø6.35 (1/4)
2	Gas piping	ø9.52 (3/8)
3	Condensation drain piping	VP25 (OD 32, ID 25)
4	Power supply/communication wiring conduits	
5	Air intake	
6	Air supply	
7	Air tie rods	Use M8-M10 bolt (4x)

Specifications

MSP Duct R32

- External static pressure range from 0 to 14 mmAq.
- Built-in electronic expansion valve (EEV) for refrigerant flow control (2000-step).
- Long-life washable permanent filter is included.
- Auto Restart function.
- Built-in condensation drain pump (750 mmH2O).
- SPI Ioniser (optional).



Indoor Unit		AC035RNMDKG/EU	AC052RNMDKG/EU	AC071RNMDKG/EU	AC100RNMDKG/EU	AC120RNMDKG/EU	AC140RNMDKG/EU
Outdoor Unit - Mono-Phase		AC035RXADKG/EU	AC052RXADKG/EU	AC071RXADKG/EU	AC100RXADKG/EU	AC120RXADKG/EU	AC140RXADKG/EU
Outdoor Unit - Tri-Phase					AC100RXADNG/EU	AC120RXADNG/EU	AC140RXADNG/EU
Capacity							
Cooling (Min/Nominal/Max)	kW	0.80/3.50/4.40	1.20/5.00/6.50	1.50/6.80/8.70	3.00/10.00/12.00	3.00/12.00/13.50	3.50/13.40/15.50
Heating @ +7 °C (Min/Nominal/Max)	kW	1.10/4.00/4.70	1.10/6.00/7.20	1.90/8.00/9.00	2.20/11.20/15.50	2.50/13.20/17.00	3.50/15.50/18.00
Heating @ -5 °C	kW	3.90	5.90	7.80	11.00	12.90	15.20
Heating @ -15 °C	kW	3.50	5.20	7.00	9.70	11.50	13.50
Performance							
Energy Efficiency Cooling	SEER ¹	W/W	6.2/ A++	6.3/ A++	6.1/ A++	5.9/ A+	5.8/ A+
	Power Consumption	kWh/a	198	278	390	593	TBA
	Pdesignc	kW	3.5	5.0	6.8	10.0	TBA
	EER	W/W	TBA	TBA	2.93	2.90	2.66
Energy Efficiency Heating	SCOP ¹	W/W	4.0/ A+	4.1/ A+	4.0/ A+	4.0/ A+	4.0/ A+
	Power Consumption	kWh/a	700	820	1,295	1,820	TBA
	Pdesignh (average)	kW	2.0	2.4	3.7	5.2	6.5
	COP ¹	W/W	TBC	TBC	3.20	3.20	3.42
Airflow Rate	Indoor Unit (H/M/L)	m ³ /min	10.4/9.2/8.0	14.5/12.0/9.5	17.0/14.0/11.0	28.0/25.0/22.0	33.0/28.0/23.0
Sound Power	Indoor Unit	dB(A)	52	55	56	58	62
	Outdoor Unit	dB(A)	61	62	65	69	70
Sound Pressure	Indoor Unit (H/M/L)	dB(A)	28/25/22	29/26/23	30/27/24	34/32/30	37/34/30
	Outdoor Unit (H/L)	dB(A)	48/48	48/48	51/49	54/52	56/54
Fan/Outdoor Unit	Type		Sirocco	Sirocco	Sirocco	Sirocco	Sirocco
	Power	W	153	153	153	153	153
	Number of Fans	-	2	2	2	3	3
External Static Pressure	Min/Std/Max	Pa	TBA	TBA	0.00/29.00/147.00	0.00/39.20/147.00	0.00/51.00/147.00
Operating Temperature Range	Cooling	°C	-15~46	-15~50	-15~50	-15~50	-15~50
	Heating	°C	-20.0~24.0	-20.0~24.0	-20.0~24.0	-20.0~24.0	-20.0~24.0
Electrical Data							
Power Source	Indoor Unit	Φ, #, V, Hz	1Φ, 2, 220~240 V, 50 Hz	1Φ, 2, 220~240 V, 50 Hz	1Φ, 2, 220~240 V, 50 Hz	1Φ, 2, 220~240 V, 50 Hz	1Φ, 2, 220~240 V, 50 Hz
	Outdoor Unit Mono-Phase	Φ, #, V, Hz	1Φ, 2, 220~240 V, 50 Hz	1Φ, 2, 220~240 V, 50 Hz	1Φ, 2, 220~240 V, 50 Hz	1Φ, 2, 220~240 V, 50 Hz	1Φ, 2, 220~240 V, 50 Hz
	Outdoor Unit Tri-Phase	Φ, #, V, Hz	-	-	3Φ, 4, 380~415 V, 50 Hz	3Φ, 4, 380~415 V, 50 Hz	3Φ, 4, 380~415 V, 50 Hz
Compressor Type	Outdoor Unit	Type	Single BLDC	Twin BLDC	Twin BLDC	Twin BLDC	Twin BLDC
Power (Min/Nominal/Max)	Cooling	kW	0.20/1.02/1.36	0.35/1.60/2.20	0.35/2.32/3.60	0.60/3.44/4.70	0.90/4.50/5.30
	Heating	kW	0.24/1.15/1.80	0.26/1.64/2.70	0.35/2.50/3.95	0.46/3.50/5.40	0.90/4.50/5.30
Current Input	Cooling (Min/Std/Max)	A	1.40/5.00/6.20	2.10/7.20/10.00	2.00/10.40/16.00	3.00/15.20/20.40	5.00/19.70/24.00
	Heating (Min/Std/Max)	A	1.3/5.4/10.5	1.7/7.4/12.0	2.0/10.8/17.0	2.5/15.4/23.0	5.0/19.7/24.0
	Cooling - Tri-Phase (Min/Std/Max)	A	-	-	-	1.5/5.3/7.1	1.9/6.9/10.0
	Heating - Tri-Phase (Min/Std/Max)	A	-	-	-	1.5/5.3/7.1	1.5/5.9/12.0
Dimensions							
Net Dimensions (W x H x D)	Indoor Unit	mm	850 x 250 x 700	850 x 250 x 700	850 x 250 x 700	1,200 x 250 x 700	1,300 x 300 x 700
	Outdoor Unit	mm	790 x 548 x 285	880 x 638 x 310	880 x 798 x 310	940 x 998 x 330	940 x 998 x 330



Indoor Unit		AC035RNMDKG/EU	AC052RNMDKG/EU	AC071RNMDKG/EU	AC100RNMDKG/EU	AC120RNMDKG/EU	AC140RNMDKG/EU
Outdoor Unit - Mono-Phase		AC035RXADKG/EU	AC052RXADKG/EU	AC071RXADKG/EU	AC100RXADKG/EU	AC120RXADKG/EU	AC140RXADKG/EU
Outdoor Unit - Tri-Phase					AC100RXADNG/EU	AC120RXADNG/EU	AC140RXADNG/EU
Net Weight	Indoor Unit	kg	26.5	26.5	26.5	34.0	38.5
	Outdoor Unit	kg	32.5	43.0	51.0	75.0	81.0
Refrigerant							
Refrigerant	Type		R32 (contains fluorinated greenhouse gases, GWP = 675)				
	Factory Charging	kg	0.9/20 m	1.2/10 m	1.7/15 m	2.7/30 m	2.7/30 m
	Charging Ton equivalent CO ₂	tCO ₂ e	0.61	0.81	1.15	1.82	1.82
	Additional Refrigerant Charging	g/m			25	50	50
Piping Connections	Liquid Pipe	ø, inch	1/4	1/4	1/4	3/8	3/8
	Gas Pipe	ø, inch	3/8	1/2	5/8	5/8	5/8
Piping Length	Min/Max	m	3/20	3/30	3/50	50	75
Piping Height	Max	m	15	20	30	30	30
Piping Connections	Drain Pipe	ø, mm	VP25 (OD 32, ID 25)	VP25 (OD 32, ID 25)	VP25 (OD 32, ID 25)	VP25 (OD 32, ID 25)	VP25 (OD 32, ID 25)
Others							
Panel	Model Code						
	Net Dimensions (W x H x D)	mm					
Accessories	Drain Pump		MDP-G075SP MDP-G075SQ	MDP-G075SP MDP-G075SQ	MDP-G075SP MDP-G075SQ	MDP-G075SP MDP-G075SQ	MDP-G075SP MDP-G075SQ
	Max. Lifting Height/Displacement	mm / litres/h	750/24	750/24	750/24	750/24	750/24

Accessories



Drain Pump (optional)	Drain Pump (optional)	Wireless Remote Controller	Touch Controller	Advanced Wired Controller	Wi-Fi Kit	Wireless Receiver Kit	External Thermostat	SPI Ioniser
MDP-G075SP	MDP-G075SQ	AR-EH03E (to be matched with MRK-A10N)	MWR-SH11N	MWR-WG00JN/ MWR-WG00KN	MIM-H04EN	MRK-A10N (to be matched with AR-EH03E)	MRW-TA	MSD-EAN1

¹Energy labels as shown are according to EU No 626/2011 (LOT 10) label classification 2019, on a scale from D to A+++.

Dimensional drawings

MSP Duct

AC035/052/060/071*NMDK*/EU

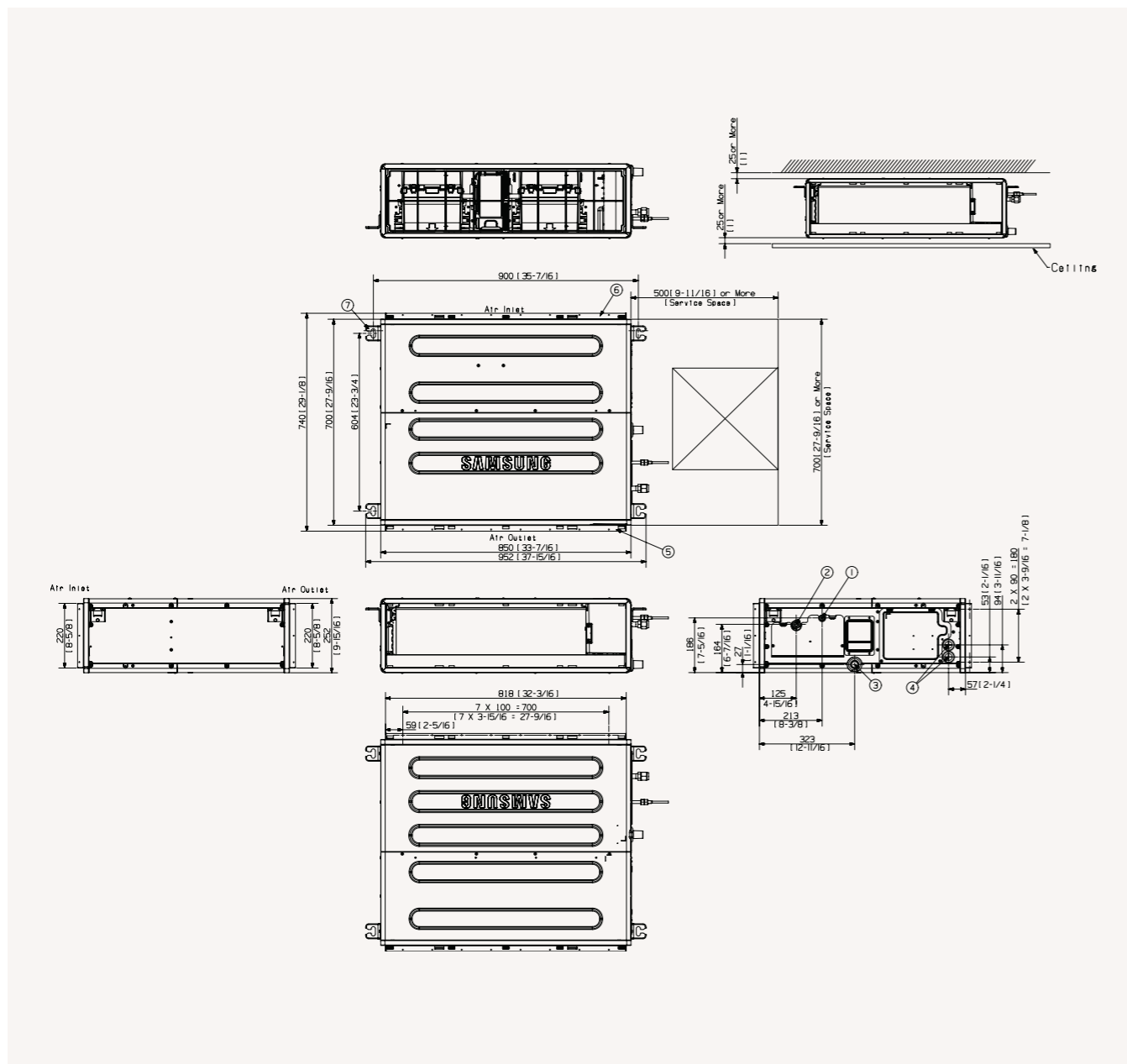

NO	Name	Description		
		AC035*NMDK*/EU	AC052*NMDK*/EU	AC060*NMDK*/EU AC071*NMDK*/EU
1	Liquid piping		ø6.35 (1/4)	
2	Gas piping	ø9.52 (3/8)	ø12.70 (1/2)	ø15.88 (5/8)
3	Condensation drain piping		VP25 (OD 32, ID 25)	
4	Power supply/communication wiring conduits		-	
5	Air intake		-	
6	Air supply		-	
7	Air tie rods		Use M8-M10 bolt (4x)	

AC090/100*NMDK*/EU

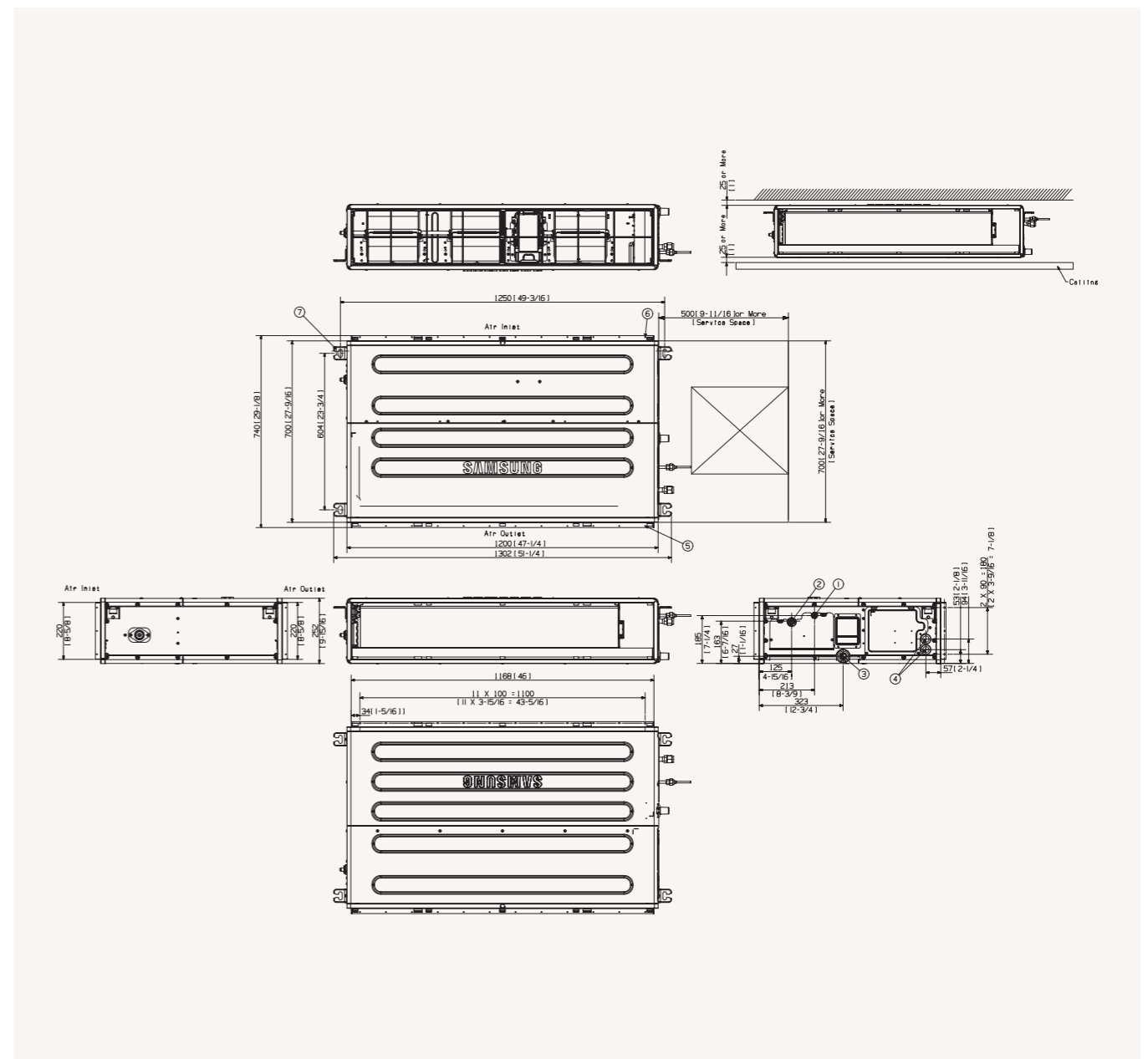

NO	Name	Description
		Description
1	Liquid piping	ø9.52 (3/8)
2	Gas piping	ø15.88 (5/8)
3	Condensation drain piping	VP25 (OD 32, ID 25)
4	Power supply/communication wiring conduits	
5	Air intake	
6	Air supply	
7	Air tie rods	Use M8-M10 bolt (4x)

Dimensional drawings

MSP Duct

AC035/052/060/071*NMDK*/EU

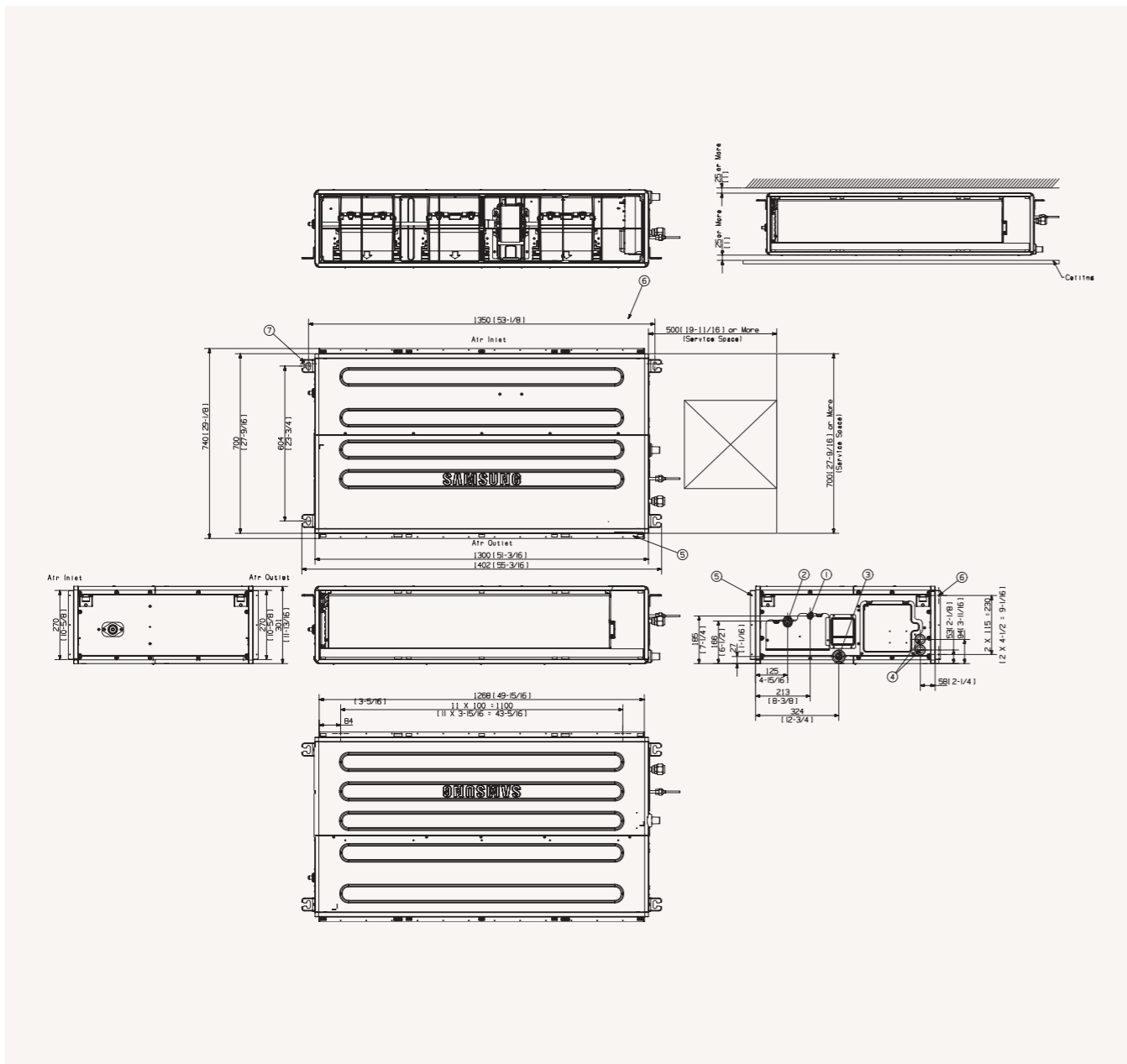

NO	Name	Description
1	Liquid piping	ø9.52 (3/8)
2	Gas piping	ø15.88 (5/8)
3	Condensation drain piping	VP25 (OD 32, ID 25)
4	Power supply/communication wiring conduits	
5	Air intake	
6	Air supply	
7	Air tie rods	Use M8-M10 bolt (4x)



Specifications

HSP Duct (R410A)

- Built-in electronic expansion valve (EEV) for refrigerant flow control (2000-step).
- Long-life washable HD 40 permanent filter is included.
- Auto Restart function.
- Condensation drain pump (optional)



Indoor Unit			AC200KNHPKH/EU	AC250KNHPKH/EU
Outdoor Unit - Mono-Phase			AC200KXAPNH/EU	AC250KXAPNH/EU
Outdoor Unit - Tri-Phase				
Capacity				
Cooling (Min/Nominal/Max)	kW		7.50/20.00/23.00	9.00/25.00/28.50
Heating @ +7 °C (Min/Nominal/Max)	kW		8.50/23.00/25.00	10.00/27.00/32.00
Heating @ -5 °C	kW		-	-
Heating @ -15 °C	kW		-	-
Performance				
Energy Efficiency Cooling	SEER	W/W	-	-
	Power Consumption	kWh/a	-	-
	Pdesignc	kW	-	-
	EER	W/W	3.10	2.61
Energy Efficiency Heating	SCOP	W/W	-	-
	Power Consumption	kWh/a	-	-
	Pdesignh (average)	kW	-	-
	COP ¹	W/W	3.45	3.24
Airflow Rate	Indoor Unit (H/M/L)	m ³ /min	72.00/62.00/48.00	80.00/64.00/51.00
Sound Power	Indoor Unit	dB(A)	70	72
	Outdoor Unit	dB(A)	75	77
Sound Pressure	Indoor Unit (H/M/L)	dB(A)	44/40/36	47/42/37
	Outdoor Unit (H/L)	dB(A)	60/58	61/59
	Type		Sirocco	Sirocco
Fan/Outdoor Unit	Power	W	630	630
	Number of Fans	-	2	2
	External Static Pressure	Min/Std/Max	Pa	49.03/72.00/196.13
Operating Temperature Range	Cooling	°C	-15~50	-15~50
	Heating	°C	-20.0~24.0	-20.0~24.0
Electrical Data				
Power Source	Indoor Unit	Φ, #, V, Hz	1Φ, 2, 220~240 V, 50 Hz	1Φ, 2, 220~240 V, 50 Hz
	Outdoor Unit Mono-Phase	Φ, #, V, Hz		
	Outdoor Unit Tri-Phase	Φ, #, V, Hz	3Φ, 4, 380~415 V, 50 Hz	3Φ, 4, 380~415 V, 50 Hz
Compressor Type	Outdoor Unit	Type	BLDC Scroll	BLDC Scroll
	Power (Min/Nominal/Max)	Cooling	kW	2.10/6.45/8.00
Current Input	Heating	kW	2.10/6.66/9.80	2.50/8.33/13.50
	Cooling (Min/Std/Max)	A		
	Heating (Min/Std/Max)	A		
	Cooling - Tri-Phase (Min/Std/Max)	A	3.8/10.0/12.3	4.7/14.9/18.4
Heating - Tri-Phase (Min/Std/Max)	A	3.8/10.3/16.0	4.5/12.9/22.0	
Dimensions				
Net Dimensions (W x H x D)	Indoor Unit	mm	1,350 x 450 x 910	1,350 x 450 x 910
	Outdoor Unit	mm	940 x 1,630 x 460	940 x 1,630 x 460
Net Weight	Indoor Unit	kg	1,350 x 450 x 910	92.0
	Outdoor Unit	kg	154.0	154.0



Indoor Unit			AC200KNHPKH/EU	AC250KNHPKH/EU
Outdoor Unit - Mono-Phase			AC200KXAPNH/EU	AC250KXAPNH/EU
Outdoor Unit - Tri-Phase				
Refrigerant				
Refrigerant	Type			
	Factory Charging	kg	6.60	6.60
	Charging Ton equivalent CO ₂	tCO ₂ e	13.78	13.78
	Additional Refrigerant Charging	g/m	-	-
Piping Connections	Liquid Pipe	ø, inch	3/8	3/8
	Gas Pipe	ø, inch	3/4	7/8
Piping Length	Min/Max	m	75	75
Piping Height	Max	m	30	30
Piping Connections	Drain Pipe	ø, mm	VP25 (OD 32, ID 25)	VP25 (OD 32, ID 25)
Others				
Panel	Model Code			
	Net Dimensions (W x H x D)	mm		
	Net Weight	kg		
Accessories	Drain Pump		DC	DC
	Max. Lifting Height/Displacement	mm / litres/h		

Accessories							
Drain Pump (optional)	Drain Pump (optional)	Wireless Remote Controller	Touch Controller	Advanced Wired Controller	Wi-Fi Kit	Wireless Receiver Kit	External Thermostat
MDP-G075SP	MDP-G075SQ	AR-EH03E (to be matched with MRK-A10N)	MWR-SH11N	MWR-WG00JN/ MWR-WG00KN	MIM-H04EN	MRK-A10N (to be matched with AR-EH03E)	MRW-TA

Dimensional drawings

HSP Duct

AC180JNHPKH/EU

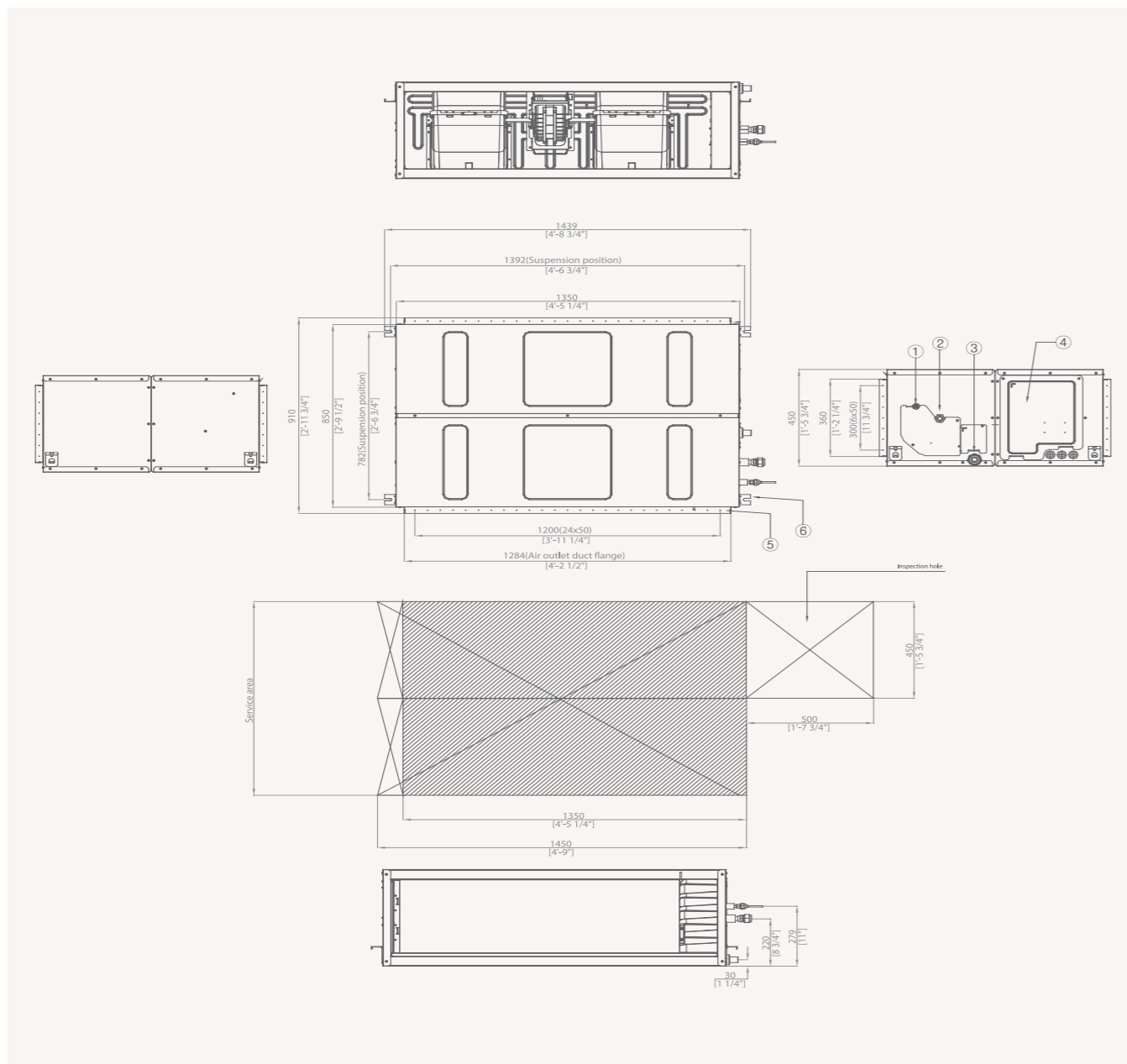

NO	Name	Description
1	Liquid piping	ø9.52 (3/8)
2	Gas piping	ø19.05 (3/4)
3	Condensation drain piping	VP25 (OD 32, ID 25)
4	Power supply/communication wiring conduits	
5	Air supply	
6	Air tie rods	Use M8-M10 bolt (4x)

HSP Duct (Big Duct)

AC200/250KNHPKH/EU

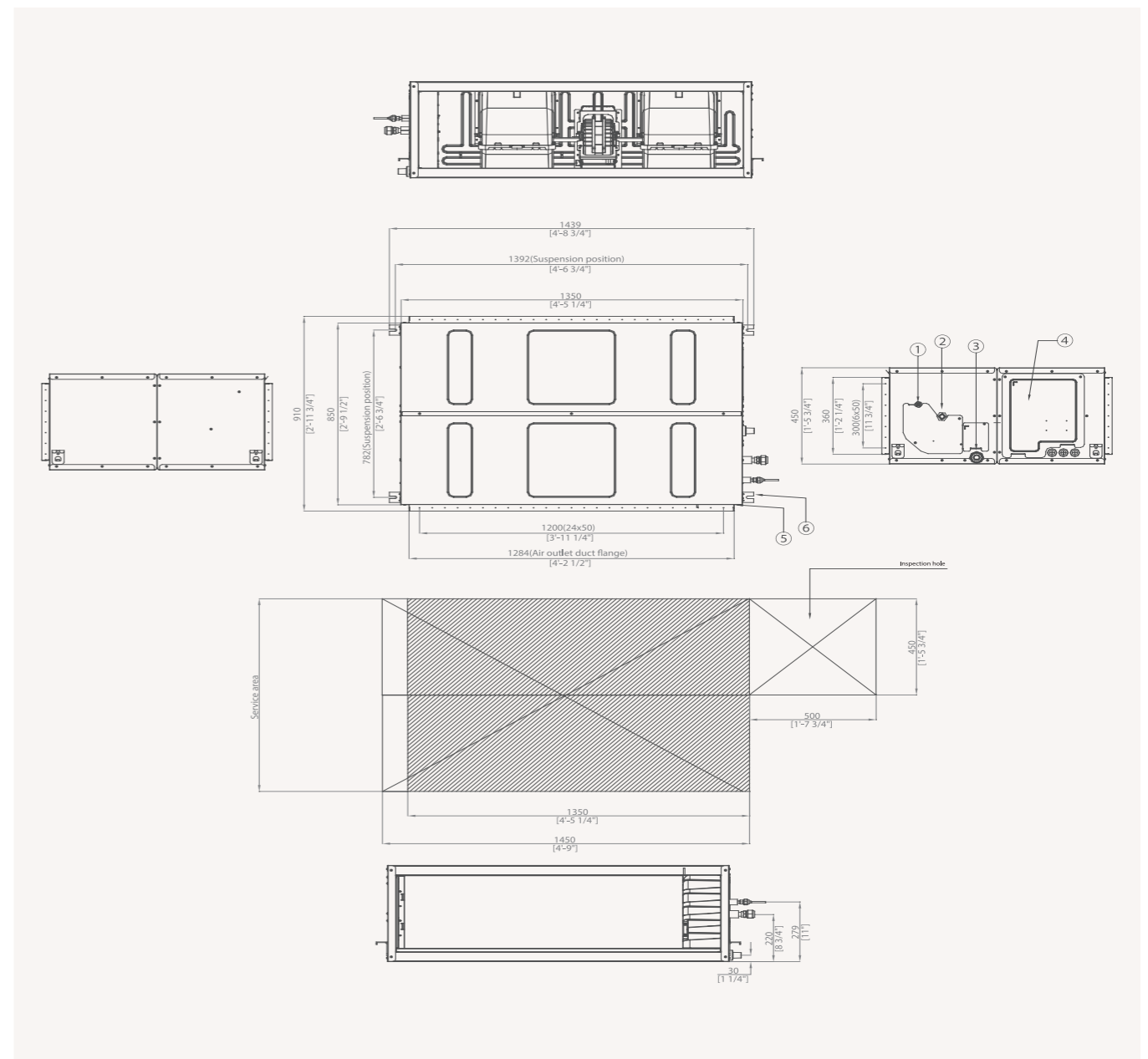

NO	Name	Description	
		AC200KNHPKH/EU	AC250KNHPKH/EU
1	Liquid piping	ø9.52 (3/8)	ø9.52 (3/8)
2	Gas piping	ø19.05 (3/4)	ø22.22 (7/8)
3	Condensation drain piping		VP25 (OD 32, ID 25)
4	Power supply/communication wiring conduits		
5	Air supply		
6	Air tie rods		

Specifications





Triangle Wall-Mounted R32

- Fan with inverter motor, HD Filter included.
- Good Sleep mode.



Indoor Unit		AC026RNADKG/EU	AC035RNADKG/EU	AC052RNADKG/EU	AC071RNADKG/EU	
Outdoor Unit - Mono-Phase		AC026RXADKG/EU	AC035RXADKG/EU	AC052RXADKG/EU	AC071RXADKG/EU	
Outdoor Unit - Tri-Phase						
Capacity						
Cooling	Cooling (Min/Nominal/Max)	kW	0.96/2.60/3.60	1.00/3.50/3.90	1.30/5.00/6.50	1.50/7.10/8.70
	Heating @ +7 °C (Min/Nominal/Max)	kW	1.00/3.30/4.00	1.10/4.00/4.70	1.50/6.00/6.25	1.90/8.00/9.00
	Heating @ -5 °C	kW	3.2	3.9	5.9	7.8
	Heating @ -15 °C	kW	2.90	3.50	5.20	7.00
Performance						
Energy Efficiency Cooling	SEER ¹	W/W	6.6/ A++	6.5/ A++	6.2/ A++	6.4/ A++
	Power Consumption	kWh/a	138	188	282	388
	Pdesignc	kW	2.6	3.5	5.0	6.4
	EER	W/W	3.51	3.18	2.27	3.02
Energy Efficiency Heating	SCOP ¹	W/W	4.0/ A+	4.0/ A+	3.9/ A	4.0/ A+
	Power Consumption	kWh/a	700	700	862	1,260
	Pdesignh (average)	kW	2.0	2.0	2.4	3.6
	COP ¹	W/W	3.00	2.58	2.79	3.27
Airflow Rate	Indoor Unit (H/M/L)	m ³ /min	7.7/6.2/5.0	8.5/7.2/5.8	10.7/9.0/7.2	17.1/14.5/12.4
Sound Power	Indoor Unit	dB(A)	56	59	60	61
	Outdoor Unit	dB(A)	59	61	62	65
Sound Pressure	Indoor Unit (H/M/L/Silent)	dB(A)	36/30/24/21	38/32/26/20	42/37/32/25	43/39/35/30
	Outdoor Unit (H/L)	dB(A)	47/46	61/48	48/48	51/49
Fan/Outdoor Unit	Type		Crossflow Fan	Crossflow Fan	Crossflow Fan	Crossflow Fan
	Power	W	27	27	27	27
	Number of Fans	-	1	1	1	1
External Static Pressure	Min/Std/Max	Pa				
Operating Temperature Range	Cooling	°C	-15-46	-15-46	-15-50	-15-50
	Heating	°C	-20.0-24.0	-20.0-24.0	-20.0-24.0	-20.0-24.0
Electrical Data						
Power Source	Indoor Unit	Φ, #, V, Hz	1Φ, 2, 220-240 V, 50 Hz	1Φ, 2, 220-240 V, 50 Hz	1Φ, 2, 220-240 V, 50 Hz	1Φ, 2, 220-240 V, 50 Hz
	Outdoor Unit Mono-Phase	Φ, #, V, Hz	1Φ, 2, 220-240 V, 50 Hz	1Φ, 2, 220-240 V, 50 Hz	1Φ, 2, 220-240 V, 50 Hz	1Φ, 2, 220-240 V, 50 Hz
	Outdoor Unit Tri-Phase	Φ, #, V, Hz				
Compressor Type	Indoor Unit	Type	Single BLDC	Single BLDC	Twin BLDC	Twin BLDC
Power (Min/Nominal/Max)	Cooling	kW	0.18/0.74/1.20	0.19/1.10/1.30	0.40/2.20/2.30	0.35/2.35/3.60
	Heating	kW	0.21/1.10/1.45	0.23/1.55/1.80	0.34/2.15/3.15	0.35/2.45/3.95
Current Input	Cooling (Min/Std/Max)	A	1.4/3.7/5.5	1.4/5.3/6.0	2.6/9.6/10.1	2.0/10.3/16.0
	Heating (Min/Std/Max)	A	1.3/5.1/7.0	1.4/6.9/10.5	2.3/9.4/14.0	2.0/10.7/17.0
	Cooling - Tri-Phase (Min/Std/Max)	A				
	Heating - Tri-Phase (Min/Std/Max)	A				
Dimensions						
Net Dimensions (W x H x D)	Indoor Unit	mm	750 x 249 x 246	750 x 249 x 246	896 x 261 x 261	1,065 x 294 x 301
	Outdoor Unit	mm	790 x 548 x 285	790 x 548 x 285	880 x 638 x 310	880 x 798 x 310
Net Weight	Indoor Unit	kg	7.6	7.6	10.8	14.4
	Outdoor Unit	kg	32.5	32.5	43.0	51.0

Indoor Unit		AC026RNADKG/EU	AC035RNADKG/EU	AC052RNADKG/EU	AC071RNADKG/EU	
Outdoor Unit - Mono-Phase		AC026RXADKG/EU	AC035RXADKG/EU	AC052RXADKG/EU	AC071RXADKG/EU	
Outdoor Unit - Tri-Phase						
Refrigerant						
Refrigerant	Type	R32 (Contains fluorinated greenhouse gases. GWP = 675)				
Factory Charging	kg	0.9/20 m	0.9/20 m	1.2/10 m	1.7/15 m	
	Charging Ton Equivalent CO ₂	tCO ₂ e	0.61	0.61	0.81	1.15
	Additional Refrigerant Charging	g/m	-	-	15	25
Piping Connections	Liquid Pipe	ø, inch	1/4	1/4	1/4	1/4
	Gas Pipe	ø, inch	3/8	3/8	1/2	5/8
Piping Length	Min/Max	m	3/20	3/20	3/30	3/50
	Max	m	15	15	20	30
Piping Connections	Drain Pipe	ø, mm	ID18	ID18	ID18	ID18

Accessories				
				
Wireless Remote Controller	Touch Controller	Advanced Wired Controller	Wi-Fi Kit	External Thermostat
AR-EH03E	MWR-SH11N	MWR-WE13N	MIM-H04EN	MRW-TA

¹Energy labels as shown are according to EU No 626/2011 (LOT10) label classification 2019, on a scale from D to A+++.

Dimensional drawings

Triangle Wall-Mounted

AC026/035*NADK*/EU

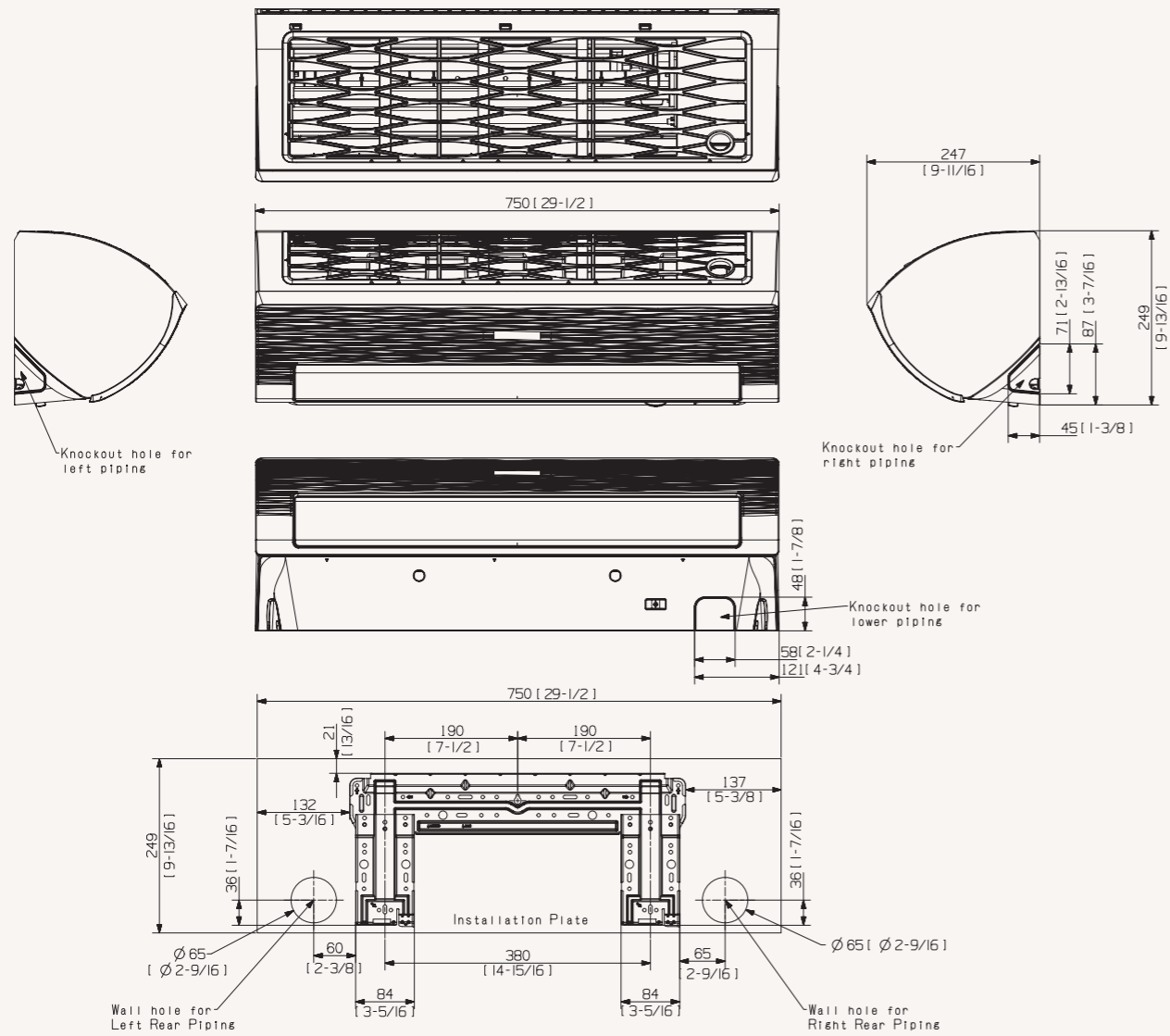

AC052*NADK*/EU

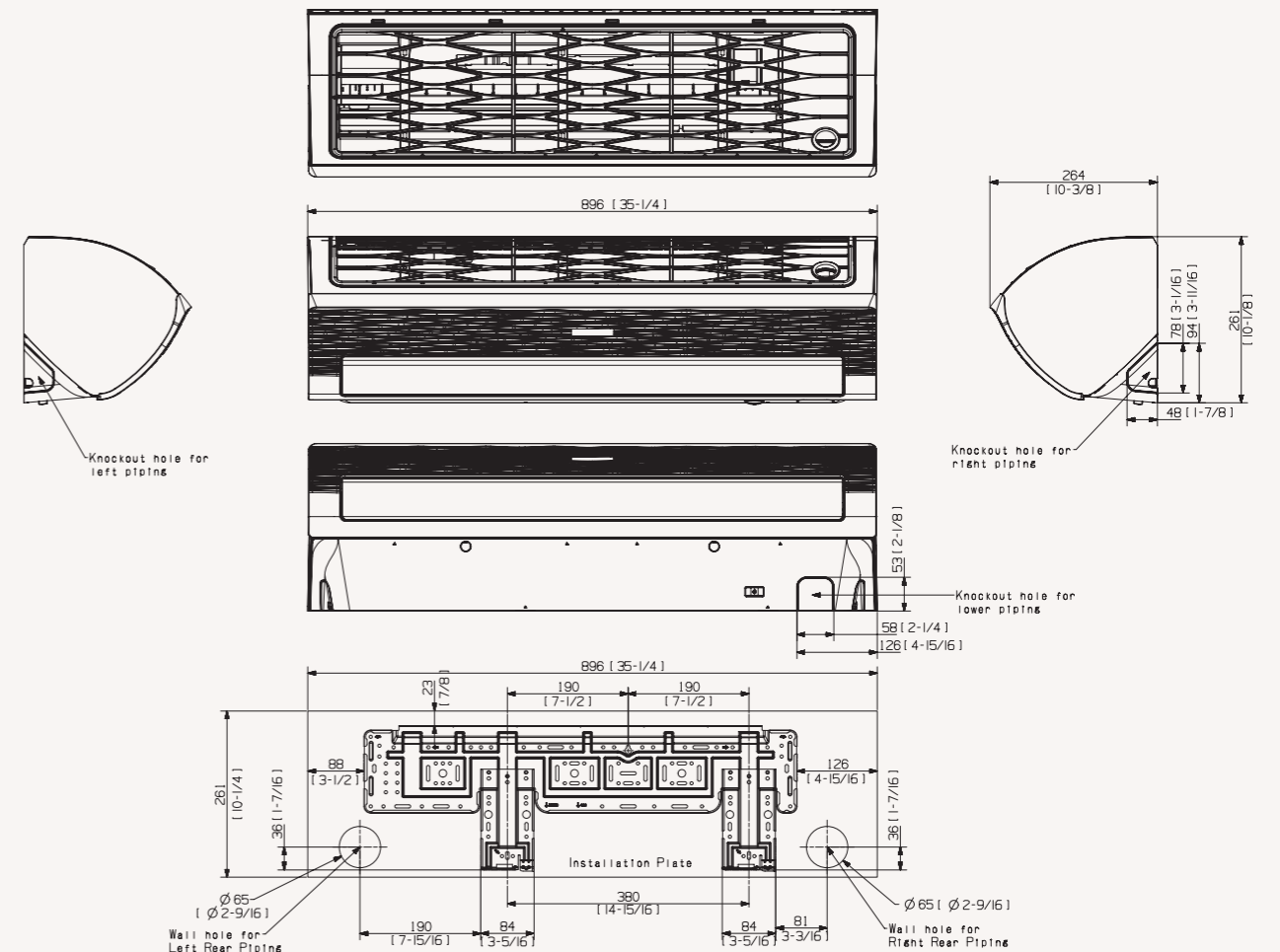

Specifications

Max Wall-Mounted R32

- Full HD Filter.
- Wi-Fi kit (optional)



Indoor Unit		AC100RNTDKG/EU	
Outdoor Unit - Mono-Phase		AC100RXADKG/EU	
Outdoor Unit - Tri-Phase		AC100RXADNG/EU	
Capacity			
Cooling (Min/Nominal/Max)	kW	3.0/9.5/11.0	
Heating @ +7 °C (Min/Nominal/Max)	kW	2.2/10.8/15.5	
Heating @ -5 °C	kW	10.6	
Heating @ -15 °C	kW	9.4	
Performance			
Energy Efficiency Cooling	SEER ¹	W/W	5.9/ A+
	Power Consumption	kWh/a	564
	Pdesignnc	kW	9.5
	EER	W/W	2.53
Energy Efficiency Heating	SCOP ¹	W/W	4.0/ A+
	Power Consumption	kWh/a	1,960
	Pdesignn (average)	kW	5.6
	COP ¹	W/W	2.82
Airflow Rate	Indoor Unit (H/M/L)	m ³ /min	22.7/19.8/17.8
Sound Power	Indoor Unit	dB(A)	65
	Outdoor Unit	dB(A)	69
Sound Pressure	Indoor Unit (H/M/L/Silent)	dB(A)	49/46/43/37
	Outdoor Unit (H/L)	dB(A)	54/52
Fan/Outdoor Unit	Type	Crossflow Fan	
	Power	W	58
	Number of Fans	-	
External Static Pressure	Min/Std/Max	Pa	
Operating Temperature Range	Cooling	°C	-15-50
	Heating	°C	-20.0-24.0
Electrical Data			
Power Source	Indoor Unit	Φ, #, V, Hz	1Φ, 2, 220-240 V, 50 Hz
	Outdoor Unit Mono-Phase	Φ, #, V, Hz	1Φ, 2, 220-240 V, 50 Hz
	Outdoor Unit Tri-Phase	Φ, #, V, Hz	3Φ, 4, 380-415 V, 50 Hz
Compressor Type	Outdoor Unit	Type	Twin BLDC
	Power (Min/Nominal/Max)	Cooling	kW
	Heating	kW	0.46/3.82/5.40
Current Input	Cooling (Min/Std/Max)	A	3.0/16.3/22.5
	Heating (Min/Std/Max)	A	2.5/16.7/23.0
	Cooling - Tri-Phase (Min/Std/Max)	A	1.5/5.7/7.7
	Heating - Tri-Phase (Min/Std/Max)	A	1.2/5.7/8.4
Dimensions			
Net Dimensions (W x H x D)	Indoor Unit	mm	1,280 x 345 x 253
	Outdoor Unit	mm	940 x 998 x 330
Net Weight	Indoor Unit	kg	18.5
	Outdoor Unit	kg	75.0
Refrigerant			
Refrigerant	Type	R32 (contains fluorinated greenhouse gases. GWP = 675)	
	Factory Charging	kg	2.7/30 m
	Charging Ton equivalent CO ₂	tCO ₂ e	1.82
	Additional Refrigerant Charging	g/m	50
Piping Connections	Liquid Pipe	ø, inch	3/8
	Gas Pipe	ø, inch	5/8
Piping Length	Min/Max	m	3/50
Piping Height	Max	m	30
Piping Connections	Drain Pipe	ø, mm	VP25 (OD 32, ID 25)

Accessories



Touch Controller

MWR-SH11N



Advanced Wired Controller

MWR-WG00JN/MWR-WG00KN



Wi-Fi Kit

MIM-H04EN



External Thermostat

MRW-TA

Dimensional drawings

Max Wall-Mounted

AC100*NTD**/EU

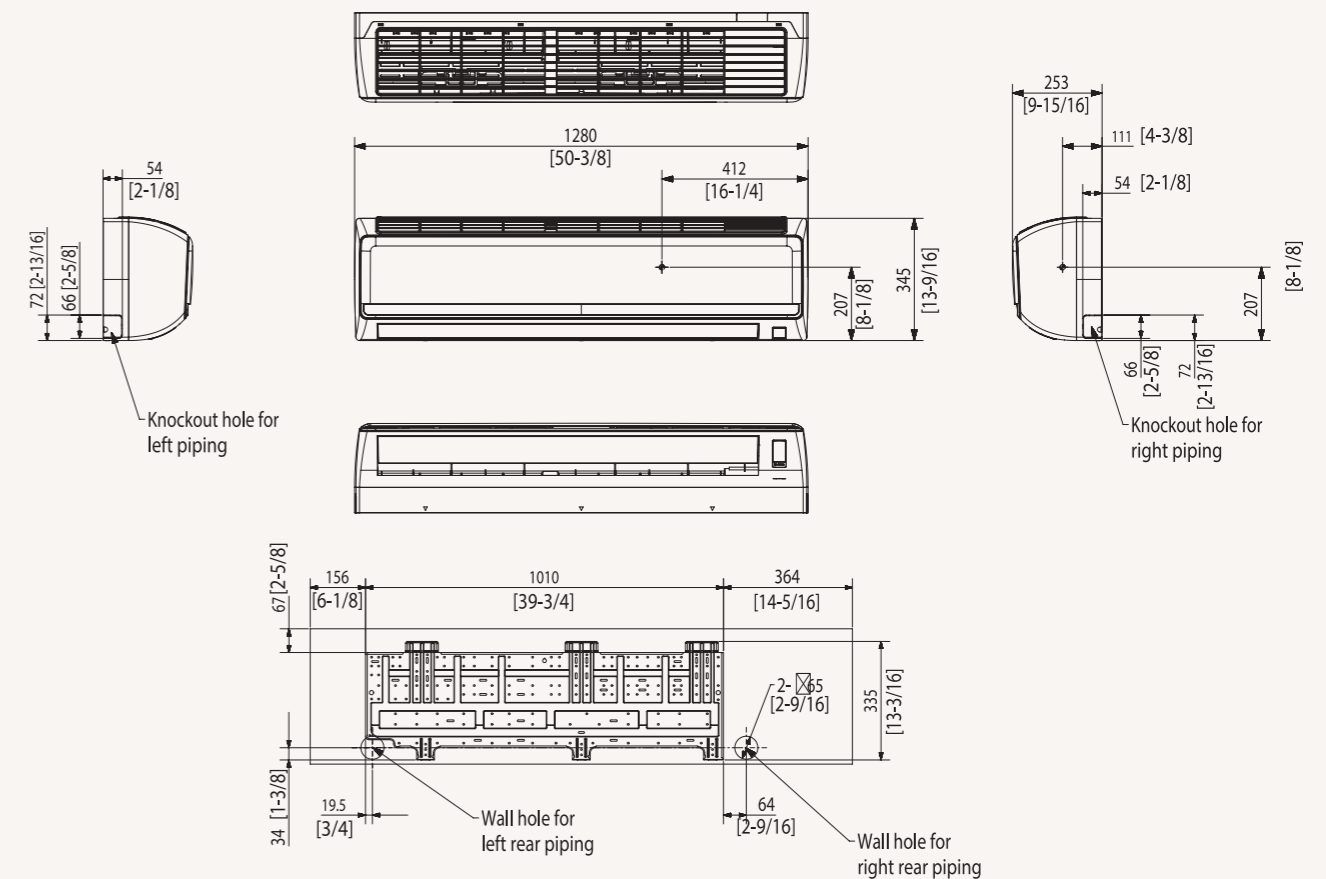

Specifications

Console R32

- SPI Ioniser (included).
- Slim design: only 100 mm in width.
- Built-in electronic expansion valve (EEV) for refrigerant flow control (2000-step).

- Two separate air outlets, upper (cooling) and bottom (heating) to avoid stratification.
- Long-life washable permanent filter.
- Auto Restart function.



Indoor Unit		AC026RNJDKG/EU	AC035RNJDKG/EU	AC052RNJDKG/EU	
Outdoor Unit - Mono-Phase		AC026RXADKG/EU	AC035RXADKG/EU	AC525RXADKG/EU	
Outdoor Unit - Tri-Phase					
Capacity					
Cooling (Min/Nominal/Max)	kW	1.0/2.6/3.4	1.0/2.6/3.4	1.9/5.0/5.5	
Heating @ +7 °C (Min/Nominal/Max)	kW	1.0/3.5/4.2	1.1/4.0/4.6	1.5/5.6/6.5	
Heating @ -5 °C	kW	3.4	3.9	5.5	
Heating @ -15 °C	kW	3.00	3.50	4.90	
Performance					
Energy Efficiency Cooling	SEER ¹	W/W	6.4/ A++	6.1/ A++	5.9/ A+
	Power Consumption	kWh/a	142	201	297
	Pdesignc	kW	2.6	3.5	5.0
	EER	W/W	3.61	3.12	2.79
Energy Efficiency Heating	SCOP ¹	W/W	4.2/ A+	4.1/ A+	4.0/ A+
	Power Consumption	kWh/a	667	683	840
	Pdesignh (average)	kW	2.0	2.0	2.4
	COP ¹	W/W	3.30	3.07	3.01
Airflow Rate	Indoor Unit (H/M/L)	m ³ /min	7.5/6.8/6.0	8.5/7.2/6.2	9.4/8.4/7.4
Sound Power	Indoor Unit	dB(A)	53	55	60
	Outdoor Unit	dB(A)	59	61	62
Sound Pressure	Indoor Unit (H/M/L/Silent)	dB(A)	36/31/26/23	38/34/30/24	43/39/35/32
	Outdoor Unit (H/L)	dB(A)	47/46	48/48	48/48
Fan/Outdoor Unit	Type		Turbo	Turbo	Turbo
	Power	W	37	35	35
	Number of Fans	-	1	1	1
External Static Pressure	Min/Std/Max	Pa			
Operating Temperature Range	Cooling	°C	-15-46	-15-46	-15-50
	Heating	°C	-20.0-24.0	-20.0-24.0	-20.0-24.0
Electrical Data					
Power Source	Indoor Unit	Φ, #, V, Hz	1Φ, 2, 220-240 V, 50 Hz	1Φ, 2, 220-240 V, 50 Hz	1Φ, 2, 220-240 V, 50 Hz
	Outdoor Unit Mono-Phase	Φ, #, V, Hz	1Φ, 2, 220-240 V, 50 Hz	1Φ, 2, 220-240 V, 50 Hz	1Φ, 2, 220-240 V, 50 Hz
	Outdoor Unit Tri-Phase	Φ, #, V, Hz			
Compressor Type	Outdoor Unit	Type	Single BLDC	Single BLDC	Twin BLDC
	Power (Min/Nominal/Max)	Cooling	kW	0.23/0.72/1.20	0.25/1.12/1.50
Heating		kW	0.21/1.06/1.45	0.21/1.30/1.80	0.25/1.86/2.50
Current Input	Cooling (Min/Std/Max)	A	1.6/3.6/5.5	1.6/5.5/7.5	2.6/8.0/10.0
		A	1.3/5.0/7.0	1.3/5.9/10.5	2.3/8.3/14.0
	Heating (Min/Std/Max)	A			
		A			
Dimensions					
Net Dimensions (W x H x D)	Indoor Unit	mm	720 x 199 x 620	720 x 199 x 620	720 x 199 x 620
	Outdoor Unit	mm	790 x 548 x 285	790 x 548 x 285	880 x 638 x 310
Net Weight	Indoor Unit	kg	16.0	16.0	16.0
	Outdoor Unit	kg	32.5	35.5	46.5
Refrigerant					
Refrigerant	Type		R32 (contains fluorinated greenhouse gases. GWP = 675)		
	Factory Charging	kg	0.9/20 m	0.9/20 m	1.2/10 m
	Charging Ton equivalent CO ₂	tCO ₂ e	0.61	0.61	0.81
	Additional Refrigerant Charging	g/m	-	-	15
Piping Connections	Liquid Pipe	ø, inch	1/4	1/4	1/4
	Gas Pipe	ø, inch	3/8	3/8	1/2
Piping Length	Min/Max	m	3/20	3/20	3/30
	Piping Height	Max	m	15	20
Piping Connections	Drain Pipe	ø, mm	ID 18	ID 18	ID 18

Accessories

-  Touch Controller
MWR-SH11N
-  Advanced Wired Controller
MWR-WG00JN/MWR-WG00KN
-  Wi-Fi Kit
MIM-H04EN
-  External Thermostat
MRW-TA

Dimensional drawings

Console

AC026/035/052*NJDK*/EU

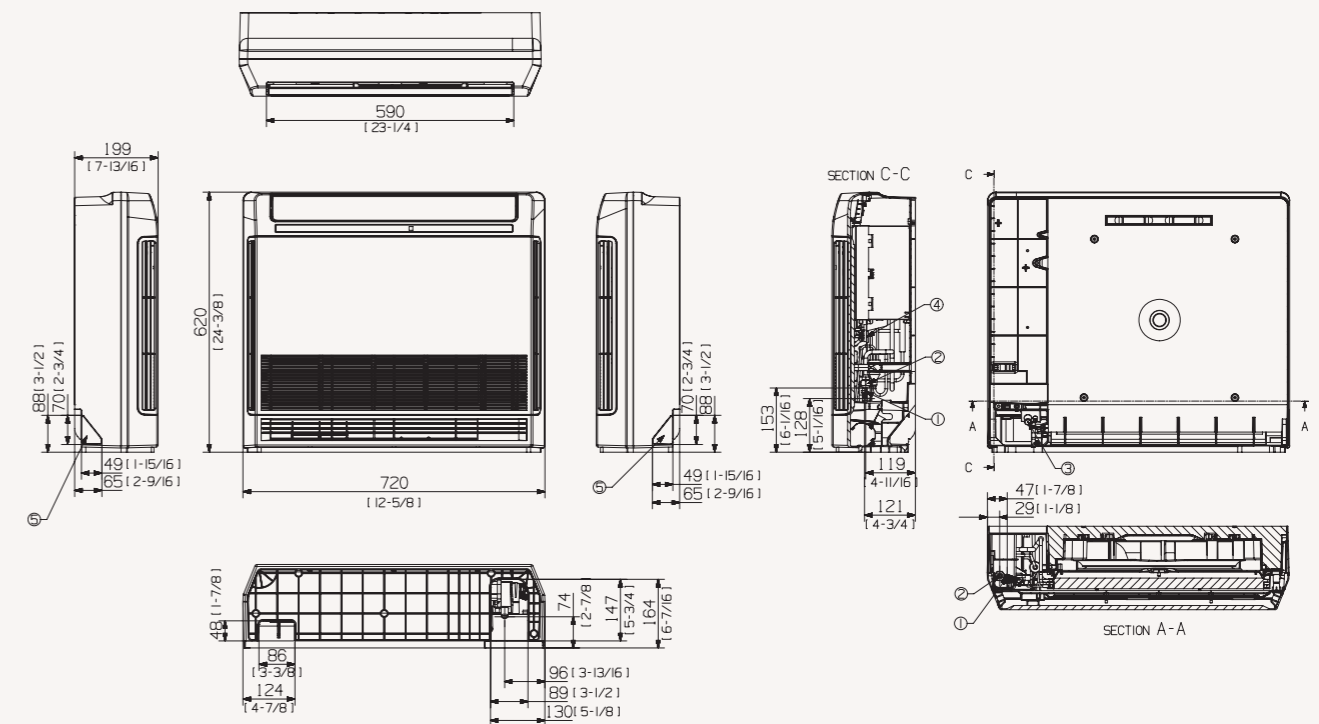

NO	Name	Description	
		AC026*NJDK*/EU	AC035*NJDK*/EU AC052*NJDK*/EU
1	Liquid piping	ø6.35 (1/4)	
2	Gas piping	ø9.52 (3/8)	ø12.70 (1/2)
3	Condensation drain piping	ID 18 [11/16] Hose	
4	Power supply/communication wiring conduits		
5	Condensation drain piping		

Specifications

Ceiling R32

- Vertical or horizontal installation.
- Air supply by means of one adjustable blade; blade angle between 4° and 45°.
- Reduced noise thanks to the remotely controlled EEV.
- Long-life washable HD 40 permanent filter is included.



Indoor Unit		AC052RNC DKG/EU	AC071RNC DKG/EU
Outdoor Unit - Mono-Phase		AC052RXADKG/EU	AC071RXADKG/EU
Outdoor Unit - Tri-Phase			
Capacity			
Cooling (Min/Nominal/Max)	kW	1.20/5.00/6.50	1.50/7.10/8.70
Heating up to +7 °C (Min/Nominal/Max)	kW	1.70/6.00/7.70	1.90/8.00/9.00
Heating @ -5 °C	kW	5.9	7.8
Heating @ -15 °C	kW	5.20	7.00
Performance			
Energy Efficiency Cooling	SEER ¹	W/W 6.1/ A++	5.6/ A+
	Power Consumption	kWh/a 273	444
	Pdesignc	kW 5.0	7.1
	EER	W/W 3.05	2.42
Energy Efficiency Heating	SCOP ¹	W/W 3.9/A	3.9/A
	Power Consumption	kWh/a 862	1,256
	Pdesignh (average)	kW 2.4	3.5
	COP ¹	W/W 3.37	2.74
Airflow Rate	Indoor Unit (H/M/L)	m ³ /min 12.6/11.3/10.0	15.2/14.1/13.1
Sound Power	Indoor Unit	dB(A) 60	64
	Outdoor Unit	dB(A) 62	65
Sound Pressure	Indoor Unit (H/M/L)	dB(A) 41/39/36	46/44/42
	Outdoor Unit (H/L)	dB(A) 48/48	51/49
Fan/Outdoor Unit	Type	Sirocco	Sirocco
	Power	W 40	40
	Number of Fans	- 2	2
External Static Pressure	Min/Std/Max	Pa	
Operating Temperature Range	Cooling	°C -15-50	-15-50
	Heating	°C -20.0-24.0	-20.0-24.0
Electrical Data			
Power Source	Indoor Unit	Φ, #, V, Hz 1Φ, 2, 220-240 V, 50 Hz	1Φ, 2, 220-240 V, 50 Hz
	Outdoor Unit Mono-Phase	Φ, #, V, Hz 1Φ, 2, 220-240 V, 50 Hz	1Φ, 2, 220-240 V, 50 Hz
	Outdoor Unit Tri-Phase	Φ, #, V, Hz	
Compressor Type	Outdoor Unit	Type Twin BLDC	Twin BLDC
Power (Min/Nominal/Max)	Cooling	kW 0.48/1.58/1.90	0.35/2.87/3.60
	Heating	kW 0.43/1.92/3.05	0.35/3.05/3.95
Current Input	Cooling (Min/Std/Max)	A 2.8/7.2/9.0	2.0/12.4/16.0
	Heating (Min/Std/Max)	A 2.4/8.5/14.5	2.0/13.2/17.0
	Cooling - Tri-Phase (Min/Std/Max)	A	
	Heating - Tri-Phase (Min/Std/Max)	A	
Dimensions			
Net Dimensions (W x H x D)	Indoor Unit	mm 1,000 x 200 x 650	1,000 x 200 x 650
	Outdoor Unit	mm 880 x 638 x 310	880 x 798 x 310
Net Weight	Indoor Unit	kg 20.0	20.0
	Outdoor Unit	kg 43.0	51.0
Refrigerant			
Refrigerant	Type	R32 (contains fluorinated greenhouse gases. GWP = 675)	
	Factory Charging	kg 1.2/10 m	1.7/15 m
	Charging Ton Equivalent CO ₂	tCO ₂ e 0.81	1.15
	Additional Refrigerant Charging	g/m 15	25
Piping Connections	Liquid Pipe	ø, inch 1/4	1/4
	Gas Pipe	ø, inch 1/2	5/8
Piping Length	Min/Max	m 3/30	3/50
Piping Height	Max	m 20	30
Piping Connections	Drain Pipe	ø, mm ID 18	ID 18

Accessories

- Touch Controller
MWR-SH11N
- Advanced Wired Controller
MWR-WG00JN/MWR-WG00KN
- Wi-Fi Kit
MIM-H04EN
- External Thermostat
MRW-TA

Dimensional drawings

Ceiling

AC052/071*NC DK*/EU

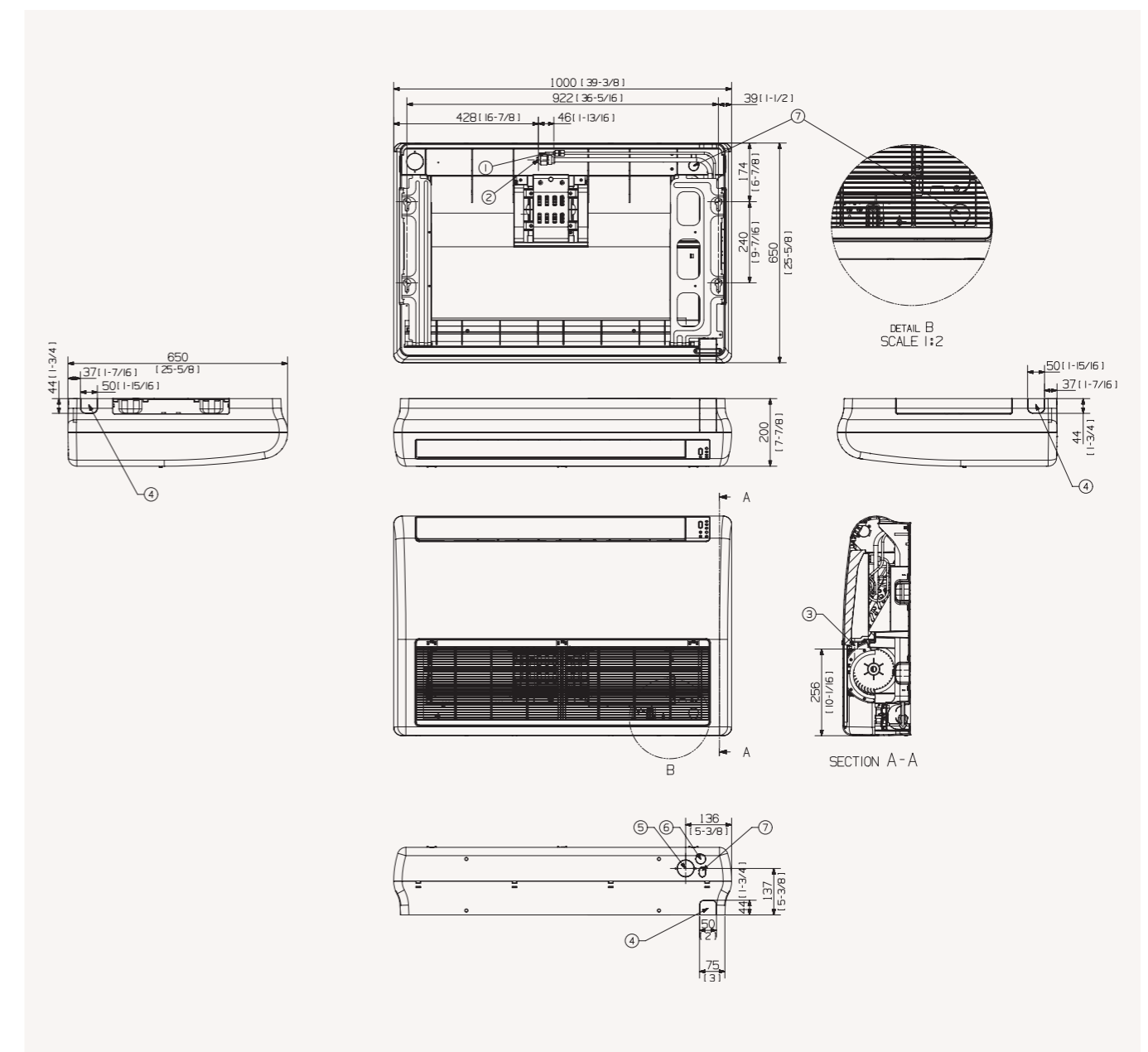

NO	Name	Description	
		AC052MNC DKH/EU	AC071MNC DKH/EU
1	Liquid piping		ø6.35 (1/4)
2	Gas piping	ø12.70 (1/2)	ø15.88 (5/8)
3	Condensation drain piping		ID 18 [11/16] Hose
4	Piping connection		
5	Connection for external air		ø50 [2]
6	Connection of the condensation drain pipe		
7	Connection of the communication cables		

Specifications

Big Ceiling R32

- Vertical or horizontal installation.
- Air supply by means of one adjustable blade; blade angle between 4° and 45°.
- Reduced noise thanks to the remotely controlled EEV.
- Long-life washable HD 40 permanent filter is included.



Indoor Unit		AC100RNCCKG/EU	AC120RNCCKG/EU	AC140RNCCKG/EU	
Outdoor Unit - Mono-Phase		AC100RXADKG/EU	AC120RXADKG/EU	AC140RXADKG/EU	
Outdoor Unit - Tri-Phase		AC100RXADNG/EU	AC120RXADNG/EU	AC140RXADNG/EU	
Capacity					
Cooling (Min/Nominal/Max)	kW	3.00/10.00/12.00	3.0/12.0/13.5	3.50/13.40/15.50	
Heating up to +7 °C (Min/Nominal/Max)	kW	3.0/12.0/13.5	3.0/12.0/13.5	3.50/15.50/18.00	
Heating @ -5 °C	kW	11.0	12.9	15.2	
Heating @ -15 °C	kW	9.7	11.5	13.5	
Performance					
Energy Efficiency Cooling	SEER ¹	6.1/ A++	5.9/ A+	6.1/ A++	
	Power Consumption	574	TBA	-	
	Pdesignc	10.0	TBA	-	
	EER	3.05	2.76	2.97	
Energy Efficiency Heating	SCOP ¹	4.0/ A+	4.0/ A+	4.0/ A+	
	Power Consumption	1,820	TBA	-	
	Pdesignh (average)	5.2	6.5	-	
	COP ¹	3.44	3.44	3.41	
Airflow Rate	Indoor Unit (H/M/L)	m ³ /min	26.0/23.0/19.0	26.0/23.0/19.0	30.0/24.0/20.0
Sound Power	Indoor Unit	dB(A)	60	62	64
	Outdoor Unit	dB(A)	69	70	69
Sound Pressure	Indoor Unit (H/M/L)	dB(A)	42/38/34	44/41/37	48/42/38
	Outdoor Unit (H/L)	dB(A)	54/52	56/54	54/53
Fan/Outdoor Unit	Type		Sirocco	Sirocco	Sirocco
	Power	W	244	244	244
	Number of Fans	-	4	4	4
External Static Pressure	Min/Std/Max	Pa			
Operating Temperature Range	Cooling	°C	-15-50	-15-50	-15-50
	Heating	°C	-20.0-24.0	-20.0-24.0	-20.0-24.0
Electrical Data					
Power Source	Indoor Unit	Φ, #, V, Hz	1Φ, 2, 220-240 V, 50 Hz	1Φ, 2, 220-240 V, 50 Hz	1Φ, 2, 220-240 V, 50 Hz
	Outdoor Unit Mono-Phase	Φ, #, V, Hz	1Φ, 2, 220-240 V, 50 Hz	1Φ, 2, 220-240 V, 50 Hz	1Φ, 2, 220-240 V, 50 Hz
	Outdoor Unit Tri-Phase	Φ, #, V, Hz	3Φ, 4, 380-415 V, 50 Hz	3Φ, 4, 380-415 V, 50 Hz	3Φ, 4, 380-415 V, 50 Hz
Compressor Type	Outdoor Unit	Type	Twin BLDC	Twin BLDC	Twin BLDC
Power (Min/Nominal/Max)	Cooling	kW	0.60/3.28/4.70	0.90/4.35/5.30	0.80/4.50/6.45
	Heating	kW	0.46/3.25/5.40	0.70/3.83/5.60	0.70/4.54/7.36
Current Input	Cooling (Min/Std/Max)	A	3.0/14.6/20.4	5.1/19.1/24.0	3.7/19.7/28.0
	Heating (Min/Std/Max)	A	2.5/14.2/23.0	3.9/17.0/26.0	3.5/19.8/32.0
	Cooling - Tri-Phase (Min/Std/Max)	A	1.5/5.0/7.1	1.7/6.6/10.0	2.1/7.0/10.5
	Heating - Tri-Phase (Min/Std/Max)	A	1.2/5.1/8.4	1.5/6.2/12.0	1.9/7.0/12.0
Dimensions					
Net Dimensions (W x H x D)	Indoor Unit	mm	1,650 x 235 x 675	1,650 x 235 x 675	1,650 x 235 x 675
	Outdoor Unit	mm	940 x 998 x 330	940 x 998 x 330	940 x 1,210 x 330
Net Weight	Indoor Unit	kg	42.0	42.0	41.5
	Outdoor Unit	kg	75.0	81.0	91.5
Refrigerant					
Refrigerant	Type		R32 (contains fluorinated greenhouse gases. GWP = 675)		
	Factory Charging	kg	2.7/30 m	2.7/30 m	2.9/30 m
	Charging Ton equivalent CO ₂	tCO ₂ e	1.82	1.82	1.96
	Additional Refrigerant Charging	g/m	50	50	50
Piping Connections	Liquid Pipe	ø, inch	3/8	3/8	3/8
	Gas Pipe	ø, inch	5/8	5/8	5/8
Piping Length	Min/Max	m	50	50	75
Piping Height	Max	m	30	30	30
Piping Connections	Drain Pipe	ø, mm	VP25 (OD 32, ID 25)	VP25 (OD 32, ID 25)	VP25 (OD 32, ID 25)

Accessories

	Touch Controller
	MWR-SH11N
	Advanced Wired Controller
	MWR-WG00JN/MWR-WG00KN
	Wi-Fi Kit
	MIM-H04EN
	External Thermostat
	MRW-TA

¹ Energy labels as shown are according to EU No 626/2011 (LOT10) label classification 2019, on a scale from D to A+++.

Dimensional drawings

Big Ceiling

AC100/120/140*NCDK*/EU / AC160JNCDEH/EU

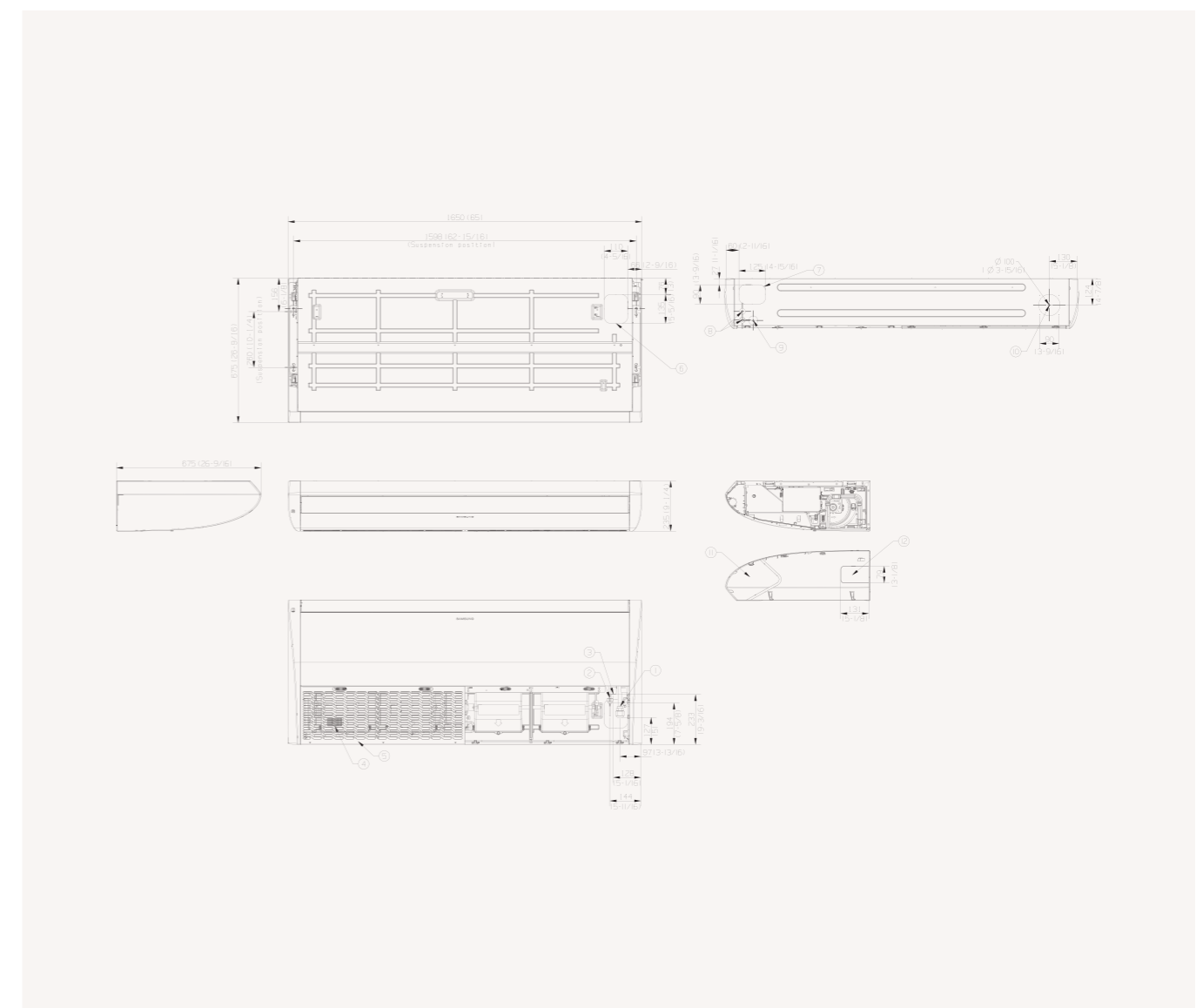

NO	Name	Description
1	Liquid pipe connection	ø9.52 (3/8)
2	Gas pipe connection	ø15.88 (5/8)
3	Drain pipe connection	VP25 (OD 32, ID 25)
4	Air Filter	
5	Air suction grille	
6	Knock-out hole for piping (upper)	
7	Knock-out hole for piping (rear)	ø28 [11/8]
8	Conduit Hole	ø42 [1 5/16]
9	Knock-out hole for drain hose	
10	Fresh air intake knock-out hole	
11	Cover side	
12	Knock-out hole for piping (side)	

Specifications

Floor-Standing (R410A)

- Built-in electronic expansion valve (EEV) for refrigerant flow control (2000-step).
- 'Silent' operation (sound pressure at low fan speed: 30-32 dB(A)).
- Long-life washable permanent filter.

- Auto Restart function.



Indoor Unit		AC100KNPDEH/EU	AC140KNPDEH/EU
Outdoor Unit - Mono-Phase		AC100KXADEH/EU	-
Outdoor Unit - Tri-Phase		-	AC140KXADGH/EU
Capacity			
Cooling (Min/Nominal/Max)	kW	3.5/10.0/12.3	4.2/13.4/16.7
Heating up to +7 °C (Min/Nominal/Max)	kW	4.2/11.2/14.0	4.0/15.5/20.0
Heating @ -5 °C	kW	11.00	15.20
Heating @ -15 °C	kW	9.60	13.5
Performance			
Energy Efficiency Cooling	SEER ¹	W/W 5.8/ A+	-
	Power Consumption	kWh/a 603	-
	Pdesignc	kW 10.0	-
	EER	W/W 2.7	3.1
Energy Efficiency Heating	SCOP ¹	W/W 4.1/ A+	-
	Power Consumption	kWh/a 1,810	-
	Pdesignh (average)	kW 5.3	-
	COP ¹	W/W 3.30	3.44
Airflow Rate	Indoor Unit (H/M/L)	m ³ /min 29.0	35.5
Sound Power	Indoor Unit	dB(A) 60	63
	Outdoor Unit	dB(A) 70	70
Sound Pressure	Indoor Unit (H/M/L)	dB(A) 47/44/41	51/48/45
	Outdoor Unit (H/L)	dB(A) 55/53	54/53
Fan/Outdoor Unit	Type	Sirocco	Sirocco
	Power	W 97	154
	Number of Fans	- 1	1
External Static Pressure	Min/Std/Max	Pa	
Operating Temperature Range	Cooling	°C -15-50	-15-50
	Heating	°C -20.0-24.0	-20.0-24.0
Electrical Data			
Power Source	Indoor Unit	Φ, #, V, Hz	1Φ, 2, 220-240 V, 50 Hz
	Outdoor Unit Mono-Phase	Φ, #, V, Hz	1Φ, 2, 220-240 V, 50 Hz
	Outdoor Unit Tri-Phase	Φ, #, V, Hz	3Φ, 4, 380-415 V, 50 Hz
Compressor Type	Outdoor Unit	Type	Twin BLDC Rotary
	Cooling	kW	1.10/3.70/4.90
Power (Min/Nominal/Max)	Heating	kW	0.90/3.39/4.50
	Cooling (Min/Std/Max)	A	4.3/16.4/23.2
Current Input	Heating (Min/Std/Max)	A	4.1/14.9/20.5
	Cooling - Tri-Phase (Min/Std/Max)	A	
	Heating - Tri-Phase (Min/Std/Max)	A	
Dimensions			
Net Dimensions (W x H x D)	Indoor Unit	mm	610 x 1,850 x 400
	Outdoor Unit	mm	940 x 998 x 330
Net Weight	Indoor Unit	kg	42.0
	Outdoor Unit	kg	72.0
Refrigerant			
Refrigerant	Type	R410A (contains fluorinated greenhouse gases. GWP = 2.088)	
	Factory Charging	kg	3.0
	Charging Ton equivalent CO ₂	tCO ₂ e	6.26
	Additional Refrigerant Charging	g/m	50
Piping Connections	Liquid Pipe	ø, inch	3/8
	Gas Pipe	ø, inch	5/8
Piping Length	Min/Max	m	50
	Max	m	30
Piping Connections	Drain Pipe	ø, mm	VP18

Accessories



Touch Controller

MWR-SH11N



Advanced Wired Controller

MWR-WG00JN/MWR-WG00KN



Wi-Fi Kit

MIM-H04EN



External Thermostat

MRW-TA

Dimensional drawings

Floor-Standing (R410A)

AC100KNPDEH/EU, AC140KNPDEH/EU

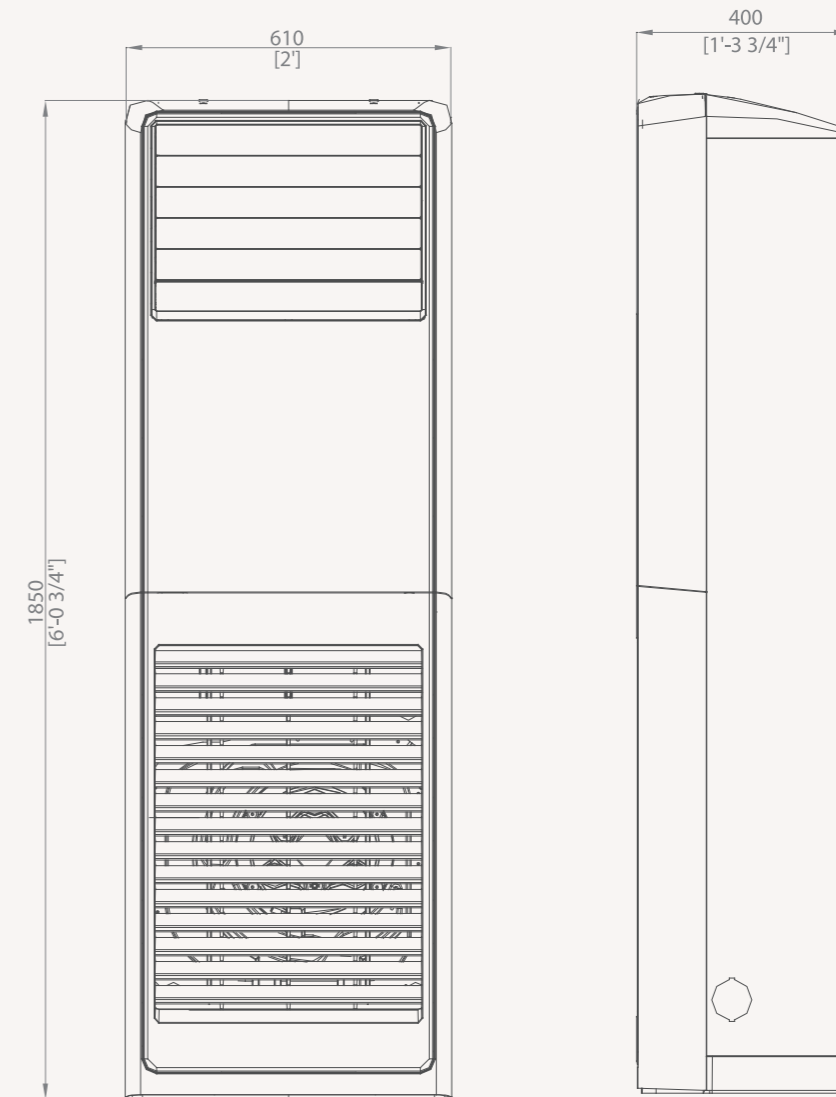

NO	Name	Description
1	Gas piping refrigerant	ø15.88 (5/8)
2	Liquid piping refrigerant	ø9.52 (3/8)
3	Condensation drain piping	

¹ Energy labels as shown are according to EU No 626/2011 (LOT10) label classification 2019, on a scale from D to A+++.

Specifications

4-Way Cassette (R410A High Efficiency)

- Four-way air supply via independently adjustable blades
- Adjustable blade angle between 35° and 63°
- Built-in condensation drain pump (750 mmH2O).
- Compatible with Wi-Fi Kit controller.
- SPI Ioniser (optional).
- Motion Detect Sensor (optional).



Indoor Unit	AC071JN4CEH/EU	AC100JN4CEH/EU	AC125JN4CEH/EU
Outdoor Unit - Mono-Phase	AC071JSCEH/EU	AC100JSCEH/EU	-
Outdoor Unit - Tri-Phase	-	AC100JXSCGH/EU	AC125JXSCGH/EU

Capacity			AC071JN4CEH/EU	AC100JN4CEH/EU	AC125JN4CEH/EU
Cooling (Min/Nominal/Max)	kW		1.70/7.10/8.50	2.20/10.00/12.00	2.20/12.50/14.00
	Heating up to +7 °C (Min/Nominal/Max)	kW	3.00/8.00/11.00	3.30/11.20/17.00	3.30/14.00/19.00
Performance					
Energy Efficiency Cooling	SEER ¹	W/W	6.7/ A++	7.0/ A++	-
	Power Consumption	kWh/a	371	500	-
	Pdesignc	kW	7.1	10.0	-
	EER	W/W	3.94	3.65	3.21
Energy Efficiency Heating	SCOP ¹	W/W	4.0/ A+	4.1/ A+	-
	Power Consumption	kWh/a	2,414	2,494	-
	Pdesignh (average)	kW	6.9	7.3	-
	COP ¹	W/W	4.02	4.01	3.71
Airflow Rate	Indoor Unit (H/M/L)	m ³ /min	19.50/17.50/15.50	30.00/24.00/18.90	30.00/24.00/18.90
Sound Power	Indoor Unit	dB(A)	53	59	60
	Outdoor Unit	dB(A)	65	66	69
Sound Pressure	Indoor Unit (H/M/L)	dB(A)	36/33/30	43/38/33	44/39/34
	Outdoor Unit (H/L)	dB(A)	49/49	50/50	52/52
Fan/Outdoor Unit	Type		Turbo	Turbo	Turbo
	Power	W	97	97	97
	Number of Fans	-	1	1	1
External Static Pressure	Min/Std/Max	Pa			
Operating Temperature Range	Cooling	°C	-20.0-50.0	-20.0-50.0	-20.0-50.0
	Heating	°C	-25-24	-25-24	-25-24
Electrical Data					
Power Source	Indoor Unit	Φ, #, V, Hz	1Φ, 2, 220-240 V, 50 Hz	1Φ, 2, 220-240 V, 50 Hz	1Φ, 2, 220-240 V, 50 Hz
	Outdoor Unit Mono-Phase	Φ, #, V, Hz	1Φ, 2, 220-240 V, 50 Hz	1Φ, 2, 220-240 V, 50 Hz	1Φ, 2, 220-240 V, 50 Hz
	Outdoor Unit Tri-Phase	Φ, #, V, Hz	-	3Φ, 4, 380-415 V, 50 Hz	3Φ, 4, 380-415 V, 50 Hz
Compressor Type	Outdoor Unit	Type	Twin BLDC Rotary	Twin BLDC Rotary	Twin BLDC Rotary
Power (Min/Nominal/Max)	Cooling	kW	0.71/1.80/2.20	0.74/2.74/3.54	0.74/3.89/4.25
	Heating	kW	0.68/1.99/5.08	0.68/2.79/6.90	0.68/3.77/7.20
Current Input	Cooling (Min/Std/Max)	A	3.60/8.10/10.00	3.60/12.00/15.60	
	Heating (Min/Std/Max)	A	3.40/9.00/22.00	3.30/12.40/30.00	
	Cooling - Tri-Phase (Min/Std/Max)	A		1.40/4.40/5.50	1.40/6.00/6.60
	Heating - Tri-Phase (Min/Std/Max)	A		1.30/4.50/11.00	1.30/6.00/11.00
Dimensions					
Net Dimensions (W x H x D)	Indoor Unit	mm	840 x 288 x 840	840 x 288 x 840	840 x 288 x 840
	Outdoor Unit	mm	940 x 1,420 x 330	940 x 1,420 x 330	940 x 1,420 x 330
Net Weight	Indoor Unit	kg	18.0	20.0	20.0
	Outdoor Unit	kg	96.0	96.0	96.0



Indoor Unit	AC071JN4CEH/EU	AC100JN4CEH/EU	AC125JN4CEH/EU
Outdoor Unit - Mono-Phase	AC071JSCEH/EU	AC100JSCEH/EU	-
Outdoor Unit - Tri-Phase	-	AC100JXSCGH/EU	AC125JXSCGH/EU

Refrigerant			R410A (contains fluorinated greenhouse gases. GWP = 2.088)		
Refrigerant	Type				
	Factory Charging	kg	2.90	2.90	2.90
	Charging Ton equivalent CO ₂	tCO ₂ e	6.06	6.06	6.06
Piping Connections	Liquid Pipe	ø, inch	3/8	3/8	3/8
	Gas Pipe	ø, inch	5/8	5/8	5/8
Piping Length	Min/Max	m	75	75	75
Piping Height	Max	m	30	30	30
Piping Connections	Drain Pipe	ø, mm	VP25 (OD 32, ID 25)	VP25 (OD 32, ID 25)	VP25 (OD 32, ID 25)
Others					
Panel	Model Code		PC4NUSKAN	PC4NUSKAN	PC4NUSKAN
	Net Dimensions (W x H x D)	mm	950 x 45 x 950	950 x 45 x 950	950 x 45 x 950
	Net Weight	kg	5.9	5.9	5.9
Accessories	Drain Pump		Included	Included	Included
	Max. Lifting Height/Displacement	mm / litres/h	750/24	750/24	750/24

Accessories

MR-EH01	MWR-SH00N	MWR-SH11N	MWR-WE13N	PC4NUSKAN	MIM-H04EN	MSD-CAN1	MCR-SMA

¹Energy labels as shown are according to EU No 626/2011 (LOT 10) label classification 2019, on a scale from D to A+++.

Specifications

Mini 4-Way Cassette (R410A High Efficiency)

- Four-way air supply via independently adjustable blades
- Adjustable blade angle between 35° and 63°
- Built-in condensation drain pump (750 mmH2O).
- Compatible with Wi-Fi Kit controller.
- SPI Ioniser (optional).
- Motion Detect Sensor (optional).



Indoor Unit		AC026JNNCEH/EU	AC035JNNCEH/EU	
Outdoor Unit - Mono-Phase		AC026JXSCEH/EU	AC035JXSCEH/EU	
Outdoor Unit - Tri-Phase		-	-	
Capacity				
Cooling (Min/Nominal/Max)	kW	0.85/2.60/3.50	0.90/3.50/4.20	
	kW	0.80/3.40/5.10	0.80/4.30/5.80	
Performance				
Energy Efficiency Cooling	SEER ¹	7.9/ A++	7.6/ A++	
	Power Consumption	kWh/a	115	161
	Pdesignc	kW	2.6	3.5
	EER	W/W	4.06	3.72
Energy Efficiency Heating	SCOP ¹	4.6/ A++	4.5/ A+	
	Power Consumption	kWh/a	761	809
	Pdesignh (average)	kW	2.5	2.6
	COP ¹	W/W	4.10	3.64
Airflow Rate	Indoor Unit (H/M/L)	m ³ /min	8.00/7.10/6.30	9.30/8.00/6.70
Sound Power	Indoor Unit	dB(A)	48	51
	Outdoor Unit	dB(A)	59	62
Sound Pressure	Indoor Unit (H/M/L)	dB(A)	32/29/25	34/30/26
	Outdoor Unit (H/L)	dB(A)	47/46	48/47
Fan/Outdoor Unit	Type		Turbo	Turbo
	Power	W	65	65
	Number of Fans	-	1	1
External Static Pressure	Min/Std/Max	Pa		
Operating Temperature Range	Cooling	°C	-20.0-50.0	-20.0-50.0
	Heating	°C	-25-24	-25-24
Electrical Data				
Power Source	Indoor Unit	Φ, #, V, Hz	1Φ, 2, 220-240 V, 50 Hz	1Φ, 2, 220-240 V, 50 Hz
	Outdoor Unit Mono-Phase	Φ, #, V, Hz	1Φ, 2, 220-240 V, 50 Hz	1Φ, 2, 220-240 V, 50 Hz
	Outdoor Unit Tri-Phase	Φ, #, V, Hz	-	-
Compressor Type	Outdoor Unit	Type	BLDC Rotary	BLDC Rotary
Power (Min/Nominal/Max)	Cooling	kW	0.24/0.64/0.89	0.19/0.94/1.26
	Heating	kW	0.16/0.83/1.50	0.16/1.18/1.65
Current Input	Cooling (Min/Std/Max)	A	1.30/3.10/4.20	1.30/4.40/5.80
	Heating (Min/Std/Max)	A	1.10/3.90/6.00	1.10/5.40/7.00
	Cooling - Tri-Phase (Min/Std/Max)	A	-	-
	Heating - Tri-Phase (Min/Std/Max)	A	-	-
Dimensions				
Net Dimensions (W x H x D)	Indoor Unit	mm	575 x 250 x 575	575 x 250 x 575
	Outdoor Unit	mm	790 x 548 x 285	790 x 548 x 285
Net Weight	Indoor Unit	kg	12.0	12.0
	Outdoor Unit	kg	35.0	35.0



Indoor Unit		AC026JNNCEH/EU	AC035JNNCEH/EU	
Outdoor Unit - Mono-Phase		AC026JXSCEH/EU	AC035JXSCEH/EU	
Outdoor Unit - Tri-Phase		-	-	
Refrigerant				
Refrigerant	Type	R410A (contains fluorinated greenhouse gases. GWP = 2.088)		
	Factory Charging	kg	1.27	1.27
	Charging Ton equivalent CO ₂	tCO ₂ e	2.65	2.65
	Additional Refrigerant Charging	g/m	-	-
Piping Connections	Liquid Pipe	ø, inch	1/4	1/4
	Gas Pipe	ø, inch	3/8	3/8
Piping Length	Min/Max	m	20	20
Piping Height	Max	m	15	15
Piping Connections	Drain Pipe	ø, mm	VP25 (OD 32, ID 25)	VP25 (OD 32, ID 25)
Others				
Panel	Model Code	PC4SUSMAN / PC4SUSMEN	PC4SUSMAN / PC4SUSMEN	
	Net Dimensions (W x H x D)	mm	670 x 45 x 670	670 x 45 x 670
	Net Weight	kg	2.7	2.7
Accessories	Drain Pump	Included		
	Max. Lifting Height/Displacement	mm / litres/h	750/24	750/24

Accessories						
						
Wireless Remote Controller	Simple Type Controller	Touch Controller	Advanced Wired Controller	Panel (Mandatory)	Wi-Fi Kit	SPI Ioniser
MR-EH01	MWR-SH00N	MWR-SH11N	MWR-WG00*N	PC4SUSMAN PC4SUSMEN	MIM-H04EN	MSD-CAN1

¹Energy labels as shown are according to EU No 626/2011 (LOT 10) label classification 2019, on a scale from D to A+++.

Specifications

MSP Duct (R410A High Efficiency)

- External static pressure range from 0 to 14 mmAq.
- Built-in electronic expansion valve (EEV) for refrigerant flow control (2000-step).
- Long-life washable permanent filter is included.
- Auto Restart function.
- Built-in condensation drain pump (750 mmH2O).
- SPI Ioniser (optional).



Indoor Unit		AC035JNMCEH/EU	AC071JNMCEH/EU	AC100JNMCEH/EU	AC125JNMCEH/EU	
Outdoor Unit - Mono-Phase		AC035JXSCEH/EU	AC071JXSCEH/EU	AC100JXSCEH/EU	-	
Outdoor Unit - Tri-Phase		-	-	AC100JXSCGH/EU	AC125JXSCGH/EU	
Capacity						
Cooling (Min/Nominal/Max)	kW	0.90/3.50/4.20	3.00/7.10/8.50	3.50/10.00/12.00	3.50/12.50/14.00	
	Heating up to +7 °C (Min/Nominal/Max)	0.80/4.30/5.80	3.00/8.00/11.00	3.70/11.20/17.00	3.70/14.00/19.00	
Performance						
Energy Efficiency Cooling	SEER ¹	6.5/ A++	6.1/ A++	6.7/ A++	-	
	Power Consumption	188	407	522	-	
	Pdesignc	3.50	7.10	10.0	-	
	EER	3.72	3.70	3.65	3.30	
Energy Efficiency Heating	SCOP ¹	4.4/ A+	4.0/ A+	4.1/ A+	-	
	Power Consumption	764	2,414	2,765	-	
	Pdesignh (average)	2.4	6.9	8.1	-	
	COP ¹	3.64	3.90	4.26/4.53	3.91	
Airflow Rate	Indoor Unit (H/M/L)	m ³ /min	12.90/11.00/9.50	21.00/18.50/16.50	36.10/29.30/24.00	38.60/33.00/26.20
Sound Power	Indoor Unit	dB(A)	56	56	61	63
	Outdoor Unit	dB(A)	62	65	66	69
Sound Pressure	Indoor Unit (H/M/L)	dB(A)	31/28/25	33/29/25	37/33/28	39/35/31
	Outdoor Unit (H/L)	dB(A)	48/47	49/49	50/50	52/52
Fan/Outdoor Unit	Type	Sirocco	Sirocco	Sirocco	Sirocco	
	Power	W	153	153	244	244
	Number of Fans	-	1	1	1	1
External Static Pressure	Min/Std/Max	Pa	0.00/24.50/147.00	0.00/29.40/147.00	0.00/39.20/147.00	0.00/50.96/147.00
Operating Temperature Range	Cooling	°C	-20.0-50.0	-20.0-50.0	-20.0-50.0	-20.0-50.0
	Heating	°C	-25-24	-25-24	-25-24	-25-24
Electrical Data						
Power Source	Indoor Unit	Φ, #, V, Hz	1Φ, 2, 220-240 V, 50 Hz	1Φ, 2, 220-240 V, 50 Hz	1Φ, 2, 220-240 V, 50 Hz	1Φ, 2, 220-240 V, 50 Hz
	Outdoor Unit Mono-Phase	Φ, #, V, Hz	1Φ, 2, 220-240 V, 50 Hz	1Φ, 2, 220-240 V, 50 Hz	1Φ, 2, 220-240 V, 50 Hz	1Φ, 2, 220-240 V, 50 Hz
	Outdoor Unit Tri-Phase	Φ, #, V, Hz	-	-	3Φ, 4, 380-415 V, 50 Hz	3Φ, 4, 380-415 V, 50 Hz
Compressor Type	Indoor Unit	Type	BLDC Rotary	Twin BLDC Rotary	Twin BLDC Rotary	Twin BLDC Rotary
Power (Min/Nominal/Max)	Cooling	kW	0.19/0.94/1.26	0.86/1.92/2.20	0.95/2.74/3.54	0.95/3.79/4.60
	Heating	kW	0.16/1.18/1.65	0.71/2.05/4.10	0.81/2.47/6.90	0.81/3.58/7.20
Current Input	Cooling (Min/Std/Max)	A	1.30/4.70/6.10	4.30/8.70/10.00	4.20/12.00/15.60	-
	Heating (Min/Std/Max)	A	1.15/5.40/7.00	3.60/9.30/18.00	4.30/11.80/30.00	-
	Cooling - Tri-Phase (Min/Std/Max)	A	-	-	1.90/4.40/5.50	1.40/6.00/7.00
	Heating - Tri-Phase (Min/Std/Max)	A	-	-	1.70/4.30/10.50	1.70/5.60/11.00
Dimensions						
Net Dimensions (W x H x D)	Indoor Unit	mm	850 x 250 x 700	1,200 x 250 x 700	1,300 x 300 x 700	1,300 x 300 x 700
	Outdoor Unit	mm	790 x 548 x 285	940 x 1,420 x 330	940 x 1,420 x 330	940 x 1,420 x 330



Indoor Unit		AC035JNMCEH/EU	AC071JNMCEH/EU	AC100JNMCEH/EU	AC125JNMCEH/EU
Outdoor Unit - Mono-Phase		AC035JXSCEH/EU	AC071JXSCEH/EU	AC100JXSCEH/EU	-
Outdoor Unit - Tri-Phase		-	-	AC100JXSCGH/EU	AC125JXSCGH/EU
Net Weight	Indoor Unit	kg	25.0	32.0	36.0
	Outdoor Unit	kg	35.0	96.0	96.0
Refrigerant					
Refrigerant	Type	R410A (contains fluorinated greenhouse gases. GWP = 2.088)			
Factory Charging	kg	1.27	2.90	2.90	2.90
	Charging Ton equivalent CO ₂	tCO ₂ e	2.65	6.06	6.06
	Additional Refrigerant Charging	g/m	-	20	50
Piping Connections	Liquid Pipe	ø, inch	1/4	3/8	3/8
	Gas Pipe	ø, inch	3/8	5/8	5/8
Piping Length	Min/Max	m	20	75	75
Piping Height	Max	m	30	30	30
Piping Connections	Drain Pipe	ø, mm	VP25 (OD 32, ID 25)	VP25 (OD 32, ID 25)	VP25 (OD 32, ID 25)
Others					
Panel	Model Code				
	Net Dimensions (W x H x D)	mm			
	Net Weight	kg			
Accessories	Drain Pump	MDP-G075SP MDP-G075SQ	MDP-G075SP MDP-G075SQ	MDP-G075SP MDP-G075SQ	MDP-G075SP MDP-G075SQ
	Max. Lifting Height/Displacement	mm / litres/h	750/24	750/24	750/24

Accessories



Drain Pump (included)	Drain Pump (optional)	Wireless Remote Controller	Touch Controller	Advanced Wired Controller	Wi-Fi Kit	Wireless Receiver Kit	External Thermostat	SPI Ioniser
MDP-G075SQ	MDP-G075SP	MR-EH01 (to be matched with MRK-A10N)	MWR-SH11N	MWR-WG00JN/ MWR-WG00KN	MIM-H04EN	MRK-A10N (to be matched with AR-EH03E)	MRW-TA	MSD-CAN1

¹Energy labels as shown are according to EU No 626/2011 (LOT 10) label classification 2019, on a scale from D to A+++.

Specifications

Max Wall-Mounted (R410A High Efficiency)

- Full HD Filter.
- Wi-Fi kit (optional).







Indoor Unit	AC100MNTCEH/EU
Outdoor Unit - Mono-Phase	AC100JXSCEH/EU
Outdoor Unit - Tri-Phase	AC100JXSCGH/EU

Capacity			
Cooling (Min/Nominal/Max)		kW	0.85/3.45/4.20
	Heating up to +7 °C (Min/Nominal/Max)	kW	0.72/3.64/6.90
Performance			
Energy Efficiency Cooling	SEER ¹	W/W	6.0/ A+
	Power Consumption	kWh/a	583
	Pdesignc	kW	10.0
	EER	W/W	2.9
Energy Efficiency Heating	SCOP ¹	W/W	4.0/ A+
	Power Consumption	kWh/a	2,275
	Pdesignh (average)	kW	6.5
	COP ¹	W/W	3.08
Airflow Rate	Indoor Unit (H/M/L)	m ³ /min	24.00/21.50/19.00
Sound Power	Indoor Unit	dB(A)	65
	Outdoor Unit	dB(A)	66
Sound Pressure	Indoor Unit (H/M/L)	dB(A)	49 (High)
	Outdoor Unit	dB(A)	1
Fan/Outdoor Unit	Type		Crossflow Fan
	Power	W	58
	Number of Fans	-	2
External Static Pressure	Min/Std/Max	Pa	
Operating Temperature Range	Cooling	°C	-20.0-50.0
	Heating	°C	-25-24
Electrical Data			
Power Source	Indoor Unit	Φ, #, V, Hz	1Φ, 2, 220-240 V, 50 Hz
	Outdoor Unit Mono-Phase	Φ, #, V, Hz	1Φ, 2, 220-240 V, 50 Hz
	Outdoor Unit Tri-Phase	Φ, #, V, Hz	3Φ, 4, 380-415 V, 50 Hz
Compressor Type	Outdoor Unit	Type	Twin BLDC Rotary
Power (Min/Nominal/Max)	Cooling	kW	0.85/3.45/4.20
	Heating	kW	0.72/3.64/6.90
Current Input	Cooling (Min/Std/Max)	A	4.2/15.1/18.5
	Heating (Min/Std/Max)	A	3.6/16.0/30.0
	Cooling - Tri-Phase (Min/Std/Max)	A	-
	Heating - Tri-Phase (Min/Std/Max)	A	-
Dimensions			
Net Dimensions (W x H x D)	Indoor Unit	mm	1,280 x 253 x 345
	Outdoor Unit	mm	940 x 1,420 x 330
Net Weight	Indoor Unit	kg	18.5
	Outdoor Unit	kg	96.0
Refrigerant			

Indoor Unit	AC100MNTCEH/EU
Outdoor Unit - Mono-Phase	AC100JXSCEH/EU
Outdoor Unit - Tri-Phase	AC100JXSCGH/EU

Refrigerant	Type	R410A (contains fluorinated greenhouse gases. GWP = 2.088)	
Factory Charging		kg	2.90
	Charging Ton equivalent CO ₂	tCO ₂ e	6.06
	Additional Refrigerant Charging	g/m	50
Piping Connections	Liquid Pipe	ø, inch	3/8
	Gas Pipe	ø, inch	5/8
Piping Length	Min/Max	m	75
Piping Height	Max	m	30
Piping Connections	Drain Pipe	ø, mm	ID 18

Accessories

			
Touch Controller	Wired Remote Controller	Wi-Fi Kit	External Thermostat
MWR-SH11N	MWR-WE13N	MIM-H04EN	MRW-TA

¹Energy labels as shown are according to EU No 626/2011 (LOT 10) label classification 2019, on a scale from D to A+++.

Dimensional drawings

Outdoor Units

2.6 kW/3.5 kW Outdoor Unit

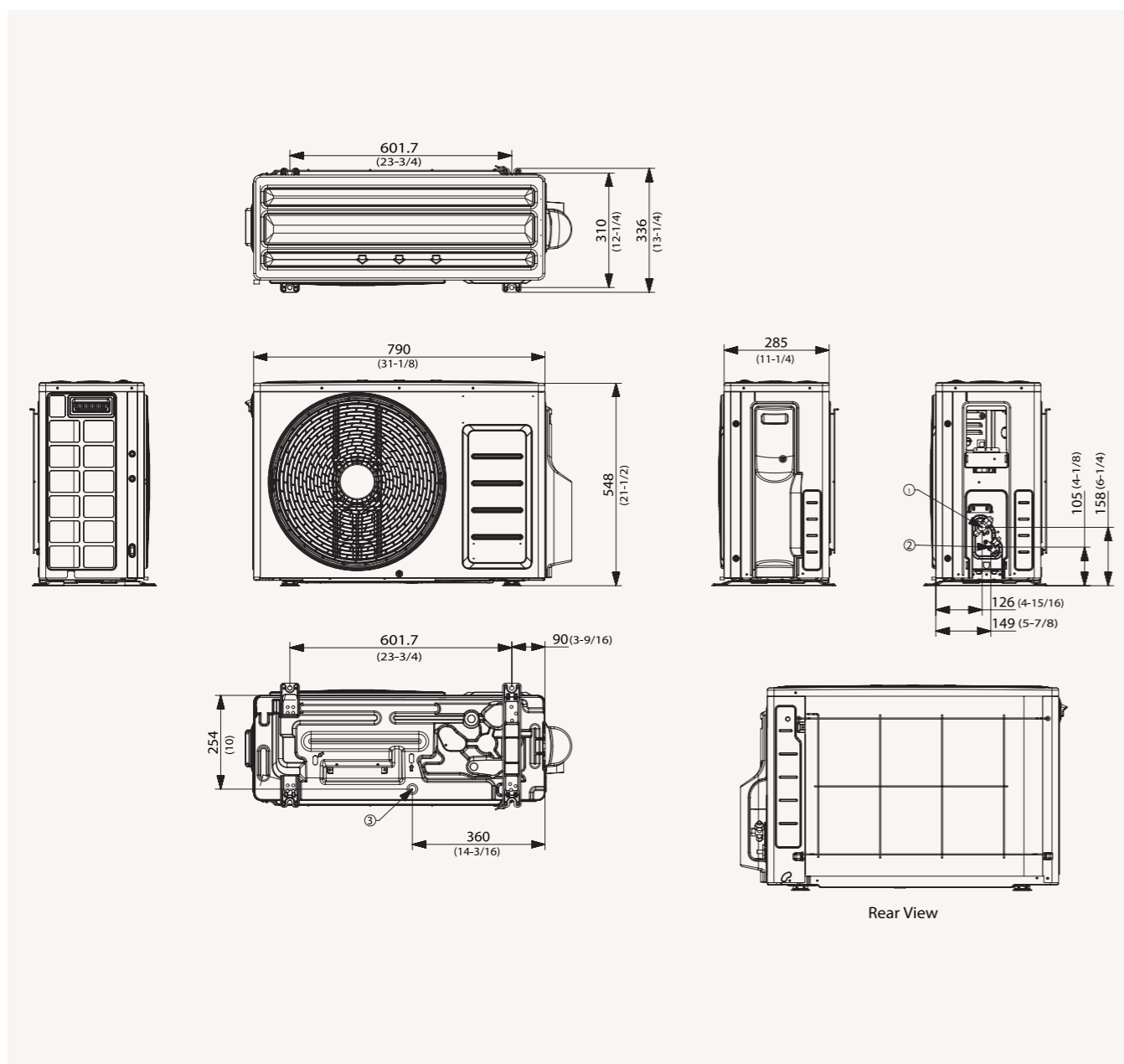

NO	Name	Description
1	Refrigerant gas pipe	ø9.52 (3/8)
2	Refrigerant liquid pipe	ø6.35 (1/4)
3	Drain hole	Connection with the provided drain plug.

5.2 kW/6.0 kW Outdoor Unit

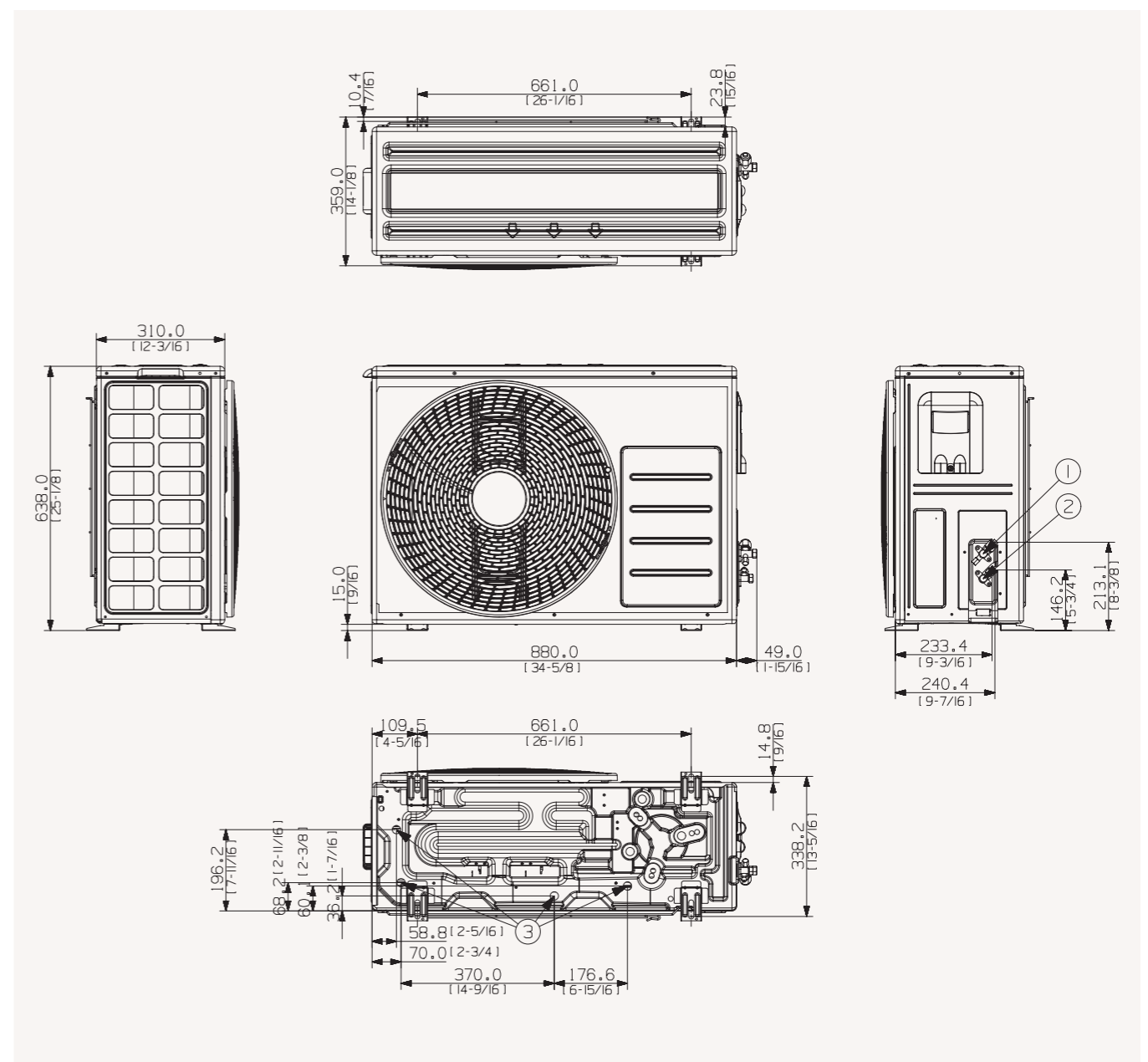

NO	Name	Description
1	Refrigerant gas pipe	ø12.70 (1/2)
2	Refrigerant liquid pipe	ø6.35 (1/4)
3	Drain hole	ø20

Dimensional drawings

Outdoor Units

7.1 kW Outdoor Unit

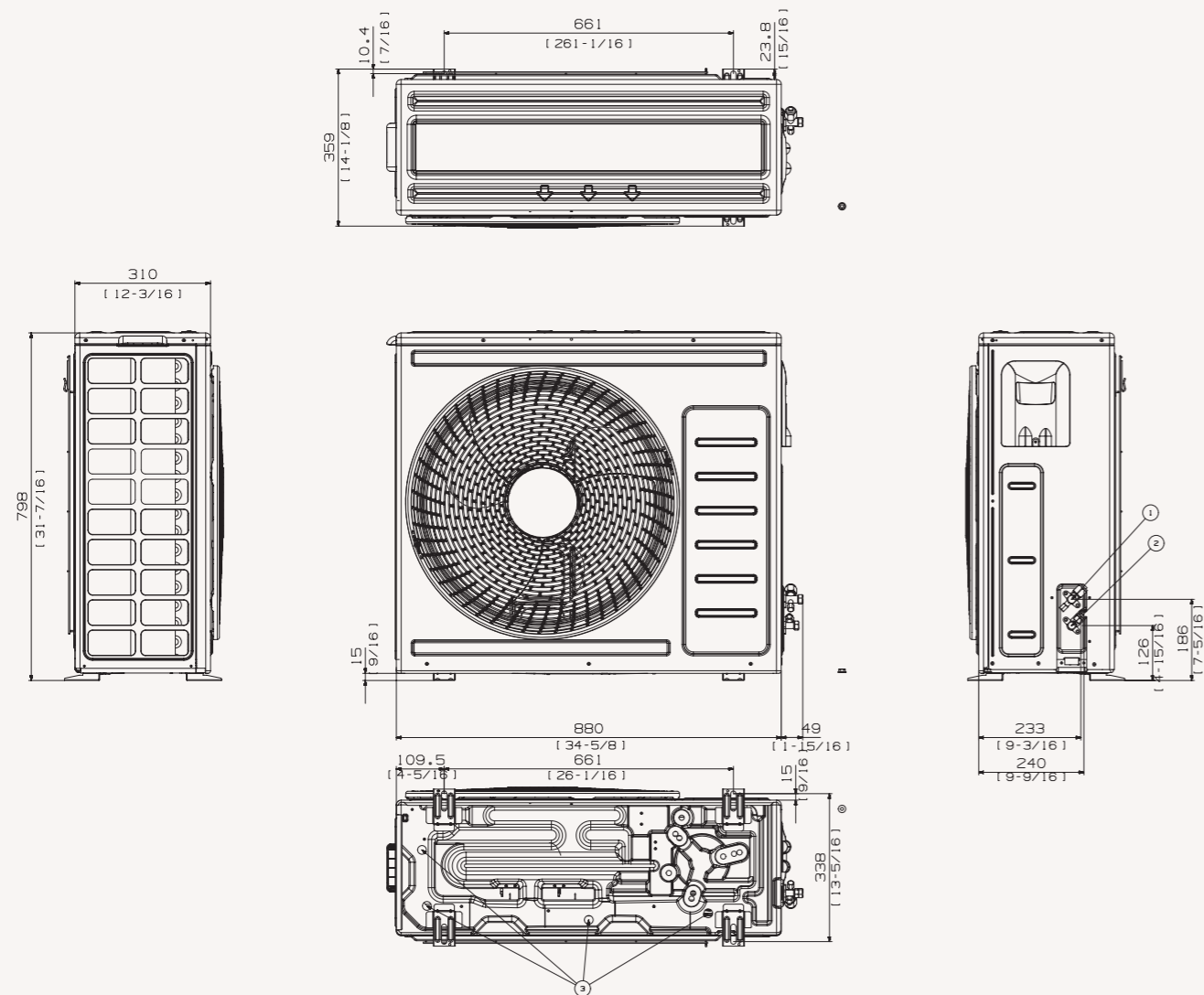

NO	Name	Description
1	Refrigerant gas pipe	ø15.88 (5/8)
2	Refrigerant liquid pipe	ø6.35 (1/4)
3	Drain hole	Connection with the provided drain plug.

9 kW/10 kW/12 kW Outdoor Unit

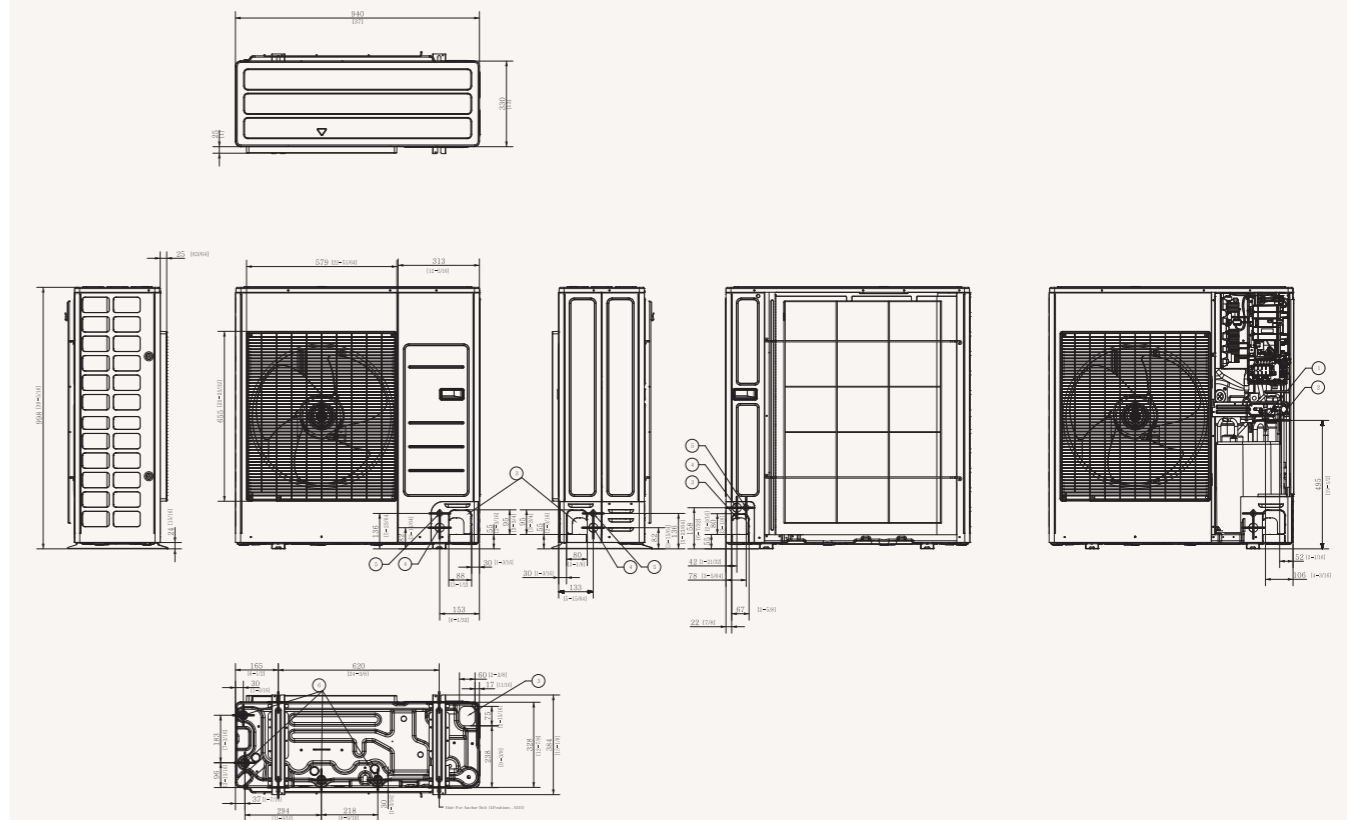

NO	Name	Description
1	Liquid pipe connection	ø9.52 (3/8)
2	Gas pipe connection	ø15.88 (5/8)
3	Piping intake knock-out hole	Front/Side/Rear/Bottom
4	Power wiring conduits	Front/Side/Rear, ø34 (ø1 3/8)
5	Communication wiring conduits	Front/Side/Rear, ø22 (ø7/8)
6	Drain hole	Connect with the provided drain plug.

Dimensional drawings

Outdoor Units

14 kW/16 kW/18 kW Outdoor Unit

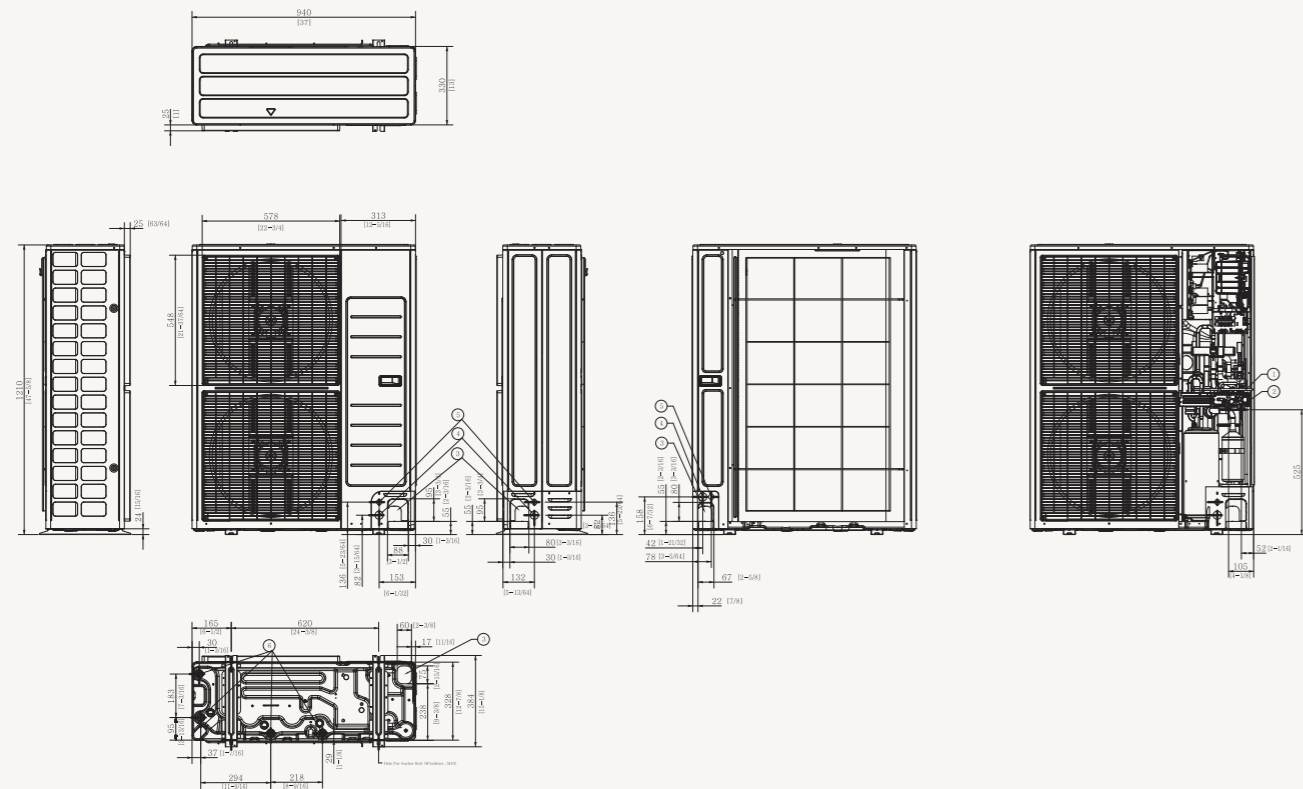

NO	Name	Description
1	Liquid pipe connection	ø9.52 (3/8)
2	Gas pipe connection	ø15.88 (5/8)
3	Piping intake knock-out hole	Front/Side/Rear/Bottom
4	Power wiring conduits	Front/Side/Rear, ø34 (ø1 3/8)
5	Communication wiring conduits	Front/Side/Rear, ø22 (ø7/8)
6	Drain hole	Connect with the provided drain plug.

20 kW/25 kW Outdoor Unit

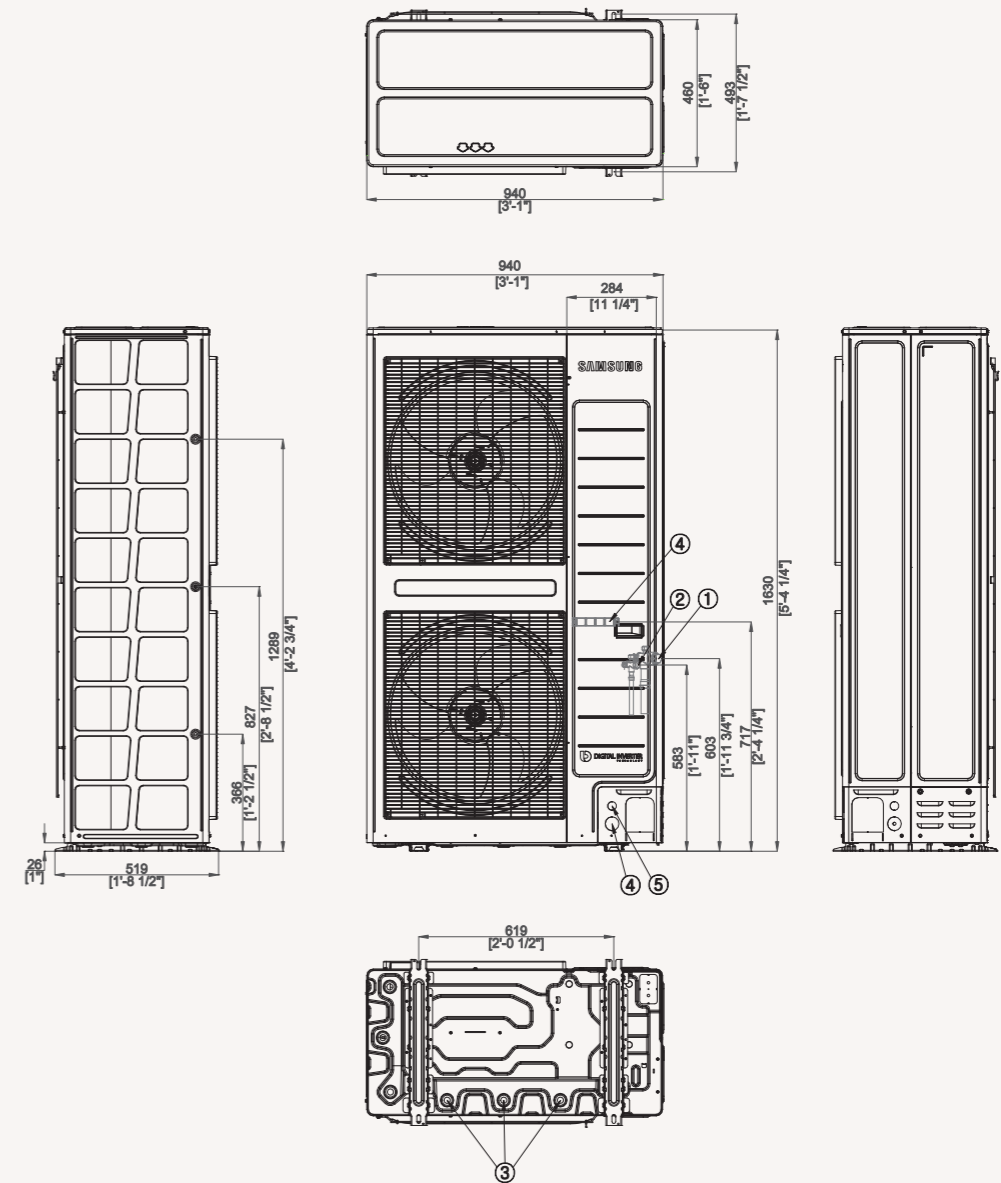











NO	Name
1	Refrigerant gas pipe
2	Refrigerant liquid pipe
3	Drain hole
4	Power wiring conduits
5	Communication wiring conduits





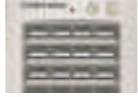



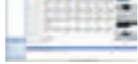

Controls

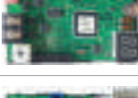

Line-up

	Product	Model	Image	Matchable Products
Individual Control System	Wireless Remote Controller	AR-EH03M AR-EH03E		DVM, FJM, CAC
	Wireless Remote Controller	AR-KH03E*		CAC, DVM *only for 360 Cassette
	Advanced Wired Controller	MWR-WG00JN MWR-WG00KN		FJM, CAC, DVM
	Simple Type Controller	MWR-SH00N		FJM, CAC, DVM
	Touch Type Controller	MWR-SH11N		FJM, CAC, DVM + Wind-Free™ function
	ERV Wired Remote Controller	MWR-VH12N		ERV
	Wireless Receiver Kit	MRK-A10		DVM, CAC (only duct models)
Centralised Control System	ON/OFF Controller	MCM-A202DN		DVM, FJM, CAC, ERV Plus, EHS Split/Mono
	Touch Centralised Controller	MCM-A300N		DVM, FJM, CAC, ERV Plus, EHS Split/Mono
	Wi-Fi Kit	MIM-H04EN		All
	Module Controller	MCM-A00N		DVM Chiller
Integrated Management System	DMS2.5	MIM-D01AN		DVM, FJM, CAC, ERV Plus, EHS Split/Mono
	S-NET3	MST-P3P		

	Product	Model	Image	Matchable Products
Gateway System	BACnet Gateway	MIM-B17BN		DVM, FJM, CAC, ERV Plus, EHS Split/Mono
	LonWorks Gateway	MIM-B18BN		DVM, FJM, CAC, ERV Plus, EHS Split/Mono
	External Contact Interface Module	MIM-B14		DVM, RAC, FJM, CAC, EHS
	PIM (Pulse Interface Module)	MIM-B16N		DVM, FJM, CAC, ERV Plus, EHS Split/Mono
	Interface Module (Converter RS485 to NASA)	MIM-N01		FJM, CAC, EHS
	ERV Interface Module (Converter RS485 to NASA)	MIM-N10		ERV
	FCU Interface Module	MIM-F10N		Chiller
Installation/ Test Run Solution	S-Converter	MIM-C02N		
Others	External Room Sensor	MRW-TA		DVM, FJM, CAC
	Operation Mode Selection Switch	MCM-C200		
	MTFC (Multi-Tenant Function Controller)	MCM-C210N		
Integrated Management System	DMS2.5	MIM-D01AN		DVM, FJM, CAC, ERV Plus, EHS Split/Mono
	S-NET3	MST-P3P		

Features and Dimensional drawings

Individual Control System		
Wireless Remote Controller AR-EH03E / AR-EH03M <ul style="list-style-type: none"> • Operation ON/OFF control • Fan speed control • Operation temperature setting • Wind-Free™ cooling function • Filter replacement alarm reset • Air swing control • Simple ON/OFF timer • Indoor unit option code setting • Option/Setting selection 		<p>48.0(1.89) 27.8(1.09) 138.0(5.43)</p>
Wireless Remote Controller AR-KH03E <ul style="list-style-type: none"> • 360 Cassette airflow direction control • Operation ON/OFF control • Fan speed control • Operation temperature setting • Filter replacement alarm reset • Simple ON/OFF timer • Indoor unit option code setting 		<p>166(6.53) 57.5(2.26) 30.5(1.20)</p>
Wired Remote Controller MWR-WE13N / MWR-WE13 (FJM Only) <p>Air conditioner/ERV control</p> <ul style="list-style-type: none"> • AC operation ON/OFF control • AC operation mode, setting temperature, fan speed, airflow direction setting • AC individual blade control (function is available when indoor unit supports any of the above functions) • ERV operation ON/OFF control • ERV operation mode, fan speed setting • AC/ERV error monitoring • Filter cleaning alert and reset alert time • Individual/group control, indoor unit/ERV interlocking control • Energy saving control • Control a maximum of 16 "Indoor unit + ERV" in a group with a single wired remote controller • 360 Cassette and Wind-Free compatible <p>Energy saving operation</p> <ul style="list-style-type: none"> • Upper/lower temperature limit setting • Automatic operation stop: automatically stops operating when not used for a certain period of time set by user <p>Weekly operation schedule setting</p> <ul style="list-style-type: none"> • Weekly operating schedule (A/C only, ERV only, A/C+ERV) • Able to set desired AC operation mode, setting temperature and fan speed to operate based on weekly reservation • Able to apply schedule exception day <p>User convenience function</p> <ul style="list-style-type: none"> • Child lock • Different button permission levels (Operation mode, temperature setting, ON/OFF, fan speed) • Real-time clock: displays current time, day (Summer time support) • Built-in room temperature sensor • Service mode support <ul style="list-style-type: none"> - Indoor unit cycle data monitoring - Indoor unit option code setting and monitoring - Indoor unit address setting and monitoring 		<p>120.0(4.72) 19.5(0.77) 124.0(4.88) 63.8(2.51)</p>
Simple Type MWR-SH00N <ul style="list-style-type: none"> • Simplified wired remote controller • AC operation ON/OFF control • Fan speed control • Setting operation mode and temperature • Reset filter cleaning alert indicator • Adjust airflow direction • Operation ON/OFF timer function 		<p>122.0(4.80) 75.0(2.95) 16.6(0.65)</p>

Touch Controller MWR-SH11N <ul style="list-style-type: none"> • Bigger Display: clear & bright backlight screen with big fonts • Wind-Free button: control Wind-Free function with just one click • Room temperature monitor and room temperature display thanks to the built-in temperature sensor • Icon/Function Lock: option of restricting icon/function on the display • Sleep Mode: help users to sleep better by controlling temperature • Outing Feature: keep room temperature above/below specific set value when the user is out of the room 		<p>119(4.72) 115(4.53) 17.6(0.69)</p>
Wireless Receiver Kit MRK-A10N MRK-A10 (FJM Only) <ul style="list-style-type: none"> • Concealed wireless signal receiver • Filter replacement sign • Fan operation display • Operation Timer setting display • Operation ON/OFF button • Operation On display LED (blue) • Defrost operation display LED (red) 		<p>80(3.14) 24(0.94) 130(5.11) 20(0.79)</p>
Centralised Control System		
ON/OFF Controller MCM-A202DN MCM-A202D (FJM Only) <ul style="list-style-type: none"> • Maximum 16-group controller (Max. 128 units) • Whole/Group/Individual indoor unit control (ON/OFF) • Restriction on the use of wireless/wired remote controllers and external contact control • Cooling and heating mode control • Indoor unit error display 		<p>118(4.65) 55(2.17) 200(7.87) 198(7.80) 262(10.31) 190(7.50) 200(7.87)</p>
Touch Centralised Controller MCM-A300N <ul style="list-style-type: none"> • 7-inch touch LCD controller • Controls a maximum of 128 indoor units • Controls a maximum of 12 zones • Schedule control, Indoor unit usage restriction, View indoor unit error history 		<p>205 163 38</p>
Wi-Fi Kit MIM-H04N <ul style="list-style-type: none"> • Controls and monitoring system air conditioner by mobile phone. (Max. 16 units) • Weekly schedule setting • Group control and monitoring (ON/OFF) • Current/daily/weekly/monthly energy usage data of outdoor unit. (This function is available in certain outdoor unit models) 		
Module Controller MCM-A00N <ul style="list-style-type: none"> • DVM CHILLER ON/OFF control (Module/Group) • Operation mode, water outlet temperature setting • Optional operation setting • Module/Group setting • Weekly operation schedule setting 		

Gateway System

**BACnet Gateway
MIM-B17BN**

With the BMS control and monitoring function, BACnet gateway makes it easy to control the air conditioning network in various ways. BACnet gateway can control up to 256 indoor units, used in combination with S-NET 3.

- Interface for BACnet management system
- Maximum of 256 indoor units plus ERVs, supported by a maximum of 80 interface modules
- Includes DMS 2.5 functions

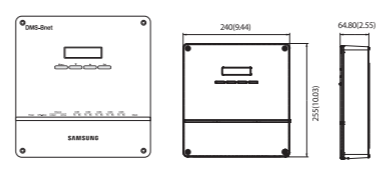

**LonWorks Gateway
MIM-B18BN**

LonWorks gateway is an interface for Lon-Connection to the LonWorks management system, providing you with a more convenient way to manage your air conditioning system. It can control a maximum of 128 indoor units, used in combination with S-NET 3.

- Exclusive use for DMS 2.5 power distribution
- Connection with up to eight watt-hour meters
- Pulse interface with watt-hour meters
- Watt-hour meter - by third party

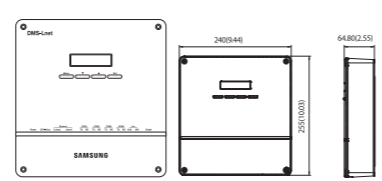

**External Contact Interface Module
MIM-B14**

Samsung Guestroom Management System saves users the energy and money wasted on cooling an unoccupied room. The air conditioner is activated when the Key-Tag is in place and turns off when the Key-Tag is removed. An external contact interface module provides direct indoor unit control via an external contact signal, as well as window-synchronised indoor unit control. The emergency control function features simple contact input. The module also generates indoor unit operation/error state output through relay contacts.

- Direct indoor unit control by external contact signal
- Window-synchronised indoor unit control
- Emergency control with simple contact input
- Indoor unit operation/error state output through relay contacts

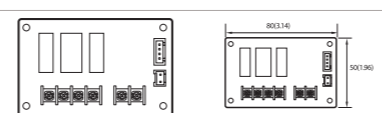

**PIM (Pulse Interface Module)
MIM-B16N**

The Watt-Hour Meter Interface Module can be exclusively used for DMS 2.5 power distribution, displaying power consumption for each watt-hour meter.

- Exclusive use for DMS 2.5 power distribution
- Connection with up to eight watt-hour meters
- Pulse interface with watt-hour meters
- Watt-hour meter - by third party

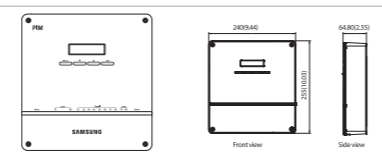

**Interface Module
MIM-N01**

Communication interface module between outdoor units and the upper level controller which makes use of a different type of communication

- Connect one interface module to one outdoor unit
- Individual control - maximum of 48 indoor units
- Group control - maximum of 16 groups
- Automatic detection of communication type: determine the communication type used by the upper level controller according to the communication type used by the outdoor unit
- Supported communication type
 - Conventional outdoor unit communication ↔ New upper level controller communication
 - New outdoor unit communication ↔ Conventional upper level controller communication

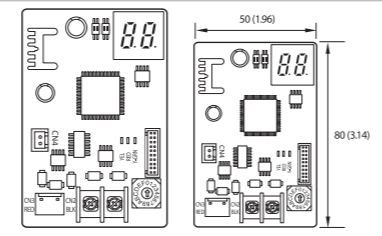

**Interface Module (Converter RS485 to NASA)
MIM-N10**

Communication interface module between new communication ERV and controller

- Connect one ERV interface module to a maximum of 16 ERVs
- Individual control - maximum of 16 ERVs
- Group control - maximum of 16 groups
- Supported communication type
 - Conventional ERV communication ↔ New upper level controller communication
 - New ERV communication ↔ Conventional upper level controller communication
 - New ERV communication ↔ New upper level controller communication

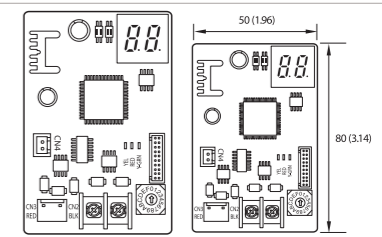

**FCU Interface Module
MIM-F10N**

Communication interface module

- Connect one FCU interface module to a maximum of 16 FCU Kits.
- Supports FCU Kit only

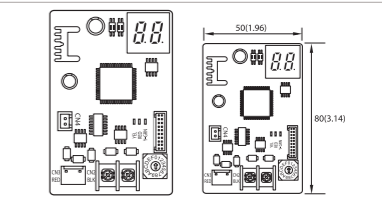

Installation/Test Run Solution

**S-Converter
MIM-C02N**

Communications converting module to connect Samsung system air conditioner to a PC.

- Main purpose for use
 - To connect with test run programme [Test run programme]
 - S-NET Pro: Conventional communication
 - S-NET Pro2: New communication

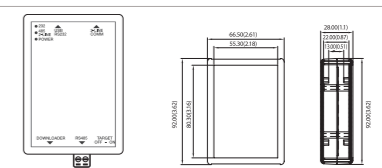

Others

**External Room Sensor
MRW-TA**

Indoor unit is operated by MRW-TA instead of its own sensor.

- Wire length: 12 m (39 ft)

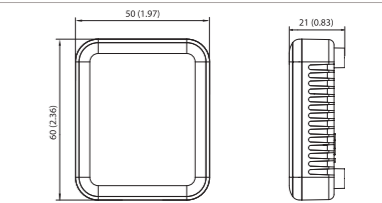

**Operation Mode Selection Switch
MCM-C200**

Outdoor unit operation mode selection (Cooling, Heating or Auto)

- Mixed operation mode protection

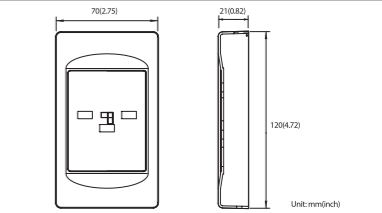

**MTFC (Multi-Tenant Function Controller)
MCM-C210N**

Multi-tenant function controller is an auxiliary power supply device which allows the indoor unit to turn off (close EEV) normally and maintain communication when the mains power supply is cut.

- It is used on sites such as hotels, where individual power is supplied to the indoor unit

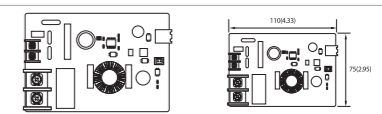



Accessories

Line-up

Classification	Image	Model DVM 5 (New Communication Protocol)	Application
Drain Pump		MDP-E075SEE3D	Slim Duct (2.0~14.0 kW)
		MDP-M075SGU1D	MSP Duct (9.0/11.2 kW)
		MDP-M075SGU2D	MSP Duct (12.8/14.0 kW) HSP Duct (11.2/14.0 kW)
		MDP-M075SGU3D	MSP Duct (5.6/7.1 kW)
		MDP-N0475NC0D	Fresh Air Intake Duct (14.0 kW)
		MDP-N0475NC1D	HSP Duct (22.4/28.0 kW) Fresh Air Intake Duct (14.0 kW)
		MDP-G075SP	Global Duct (External Type)
CAC AHU Kit		MDP-G075SQ	Global Duct (Internal Type)
		MXD-K100XN	7.00~8.75 kW AHU
Humidifier		MVO-VA050100	500 m3/hr (ERV Plus)
		MVO-VA100100	1,000 m3/hr (ERV Plus)
360 Cassette Front Panel		PC4NUDMAN	NASA, Square
		PC4NBDMAN	NASA, Square - Black
		PC4NUNMAN	NASA, Circle (exposed installation)
		PC4NBNMAN	NASA, Circle (exposed installation) - Black
Wind-Free™ 4-Way Cassette Front Panel		PC4NUFMAN	Wind-Free™ 4-Way Cassette
4-Way Cassette Front Panel		PC4NUSKAN	4-Way Cassette S - Waffle
		PC4NUSKEN	4-Way Cassette S - Classic
		PC4NBSKAN	4-Way Cassette S - Black
Wind-Free™ 4-Way Cassette Front Panel (600 x 600)		PC4SUFMAN	Wind-Free™ 4-Way Cassette (600 x 600)
Wind-Free™ 1-Way Cassette Front Panel		PC1NWFMAN	
1-Way Cassette Front Panel		PC1BWSMAN	1-Way Cassette (New Air Fluid Design) (1.7~2.2 kW)
		PC1NUSMAN	Slim 1-Way Cassette (2.2~3.5 kW)
		PC1NUPMAN	Slim 1-Way Cassette Z-Sliding (2.2~3.5 kW)
2-Way Cassette Front Panel		PC2NUSMEN	2-Way Cassette
SPI Ioniser		MSD-CAN1	4-Way Cassette, 4-Way Mini Cassette, 360 Cassette, Ceiling (optional) Console (included)
		MSD-EAN1	Duct S, Big Duct, ERV, ERV Plus (optional)
Motion Detect Sensor		MCR-SMA	4-Way Cassette S (600 x 600)
		MCR-SMC	Wind-Free™ 4-Way Cassette
		MCR-SMD	Wind-Free™ Mini 4-Way Cassette

Design and support



Samsung Climate Solutions Partner Portal

As one of Samsung's registered Climate Solutions partners, you will have access to our Partner Portal and its many benefits. Whether you are looking for marketing materials or technical product documentation, requesting technical support or registering for training, the Samsung Climate Solutions Partner Portal offers you everything you need to consistently deliver the best results.

Access technical resources

The Technical Resources section provides you with all of the relevant information you need to understand the product's functionality and to prepare and design projects. A library full of technical information is at your fingertips, ranging from technical data books, BIM files and certificates to exploded views, drawings and different kinds of manuals.



Obtain marketing resources

Potential buyers like to know that you are on the cutting edge of Samsung's latest innovations. To enable you to align with Samsung's marketing initiatives, the Partner Portal provides you with useful downloadable assets such as images and videos, designed to make your marketing activities easy and effective.

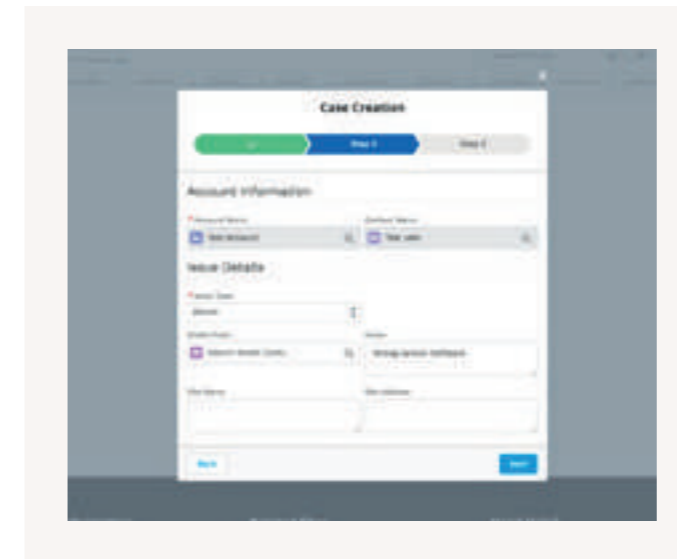

Request technical support

You can easily request technical support through the Samsung Partner Portal by reporting your case using our built-in ticketing system. You can rest assured that our well-trained technical experts will work to solve your issue as soon as possible.

Register for training

If you are dedicated to becoming a Samsung climate solutions expert, you can access Samsung's educational portal for training sessions provided by experienced trainers. The portal allows you to search for online courses and materials, test your climate solutions knowledge, and more. The Samsung Business Academy is here to help you succeed.¹

¹ The registration process for and availability of training courses may vary per country. Please contact your direct Samsung contact person for more information.

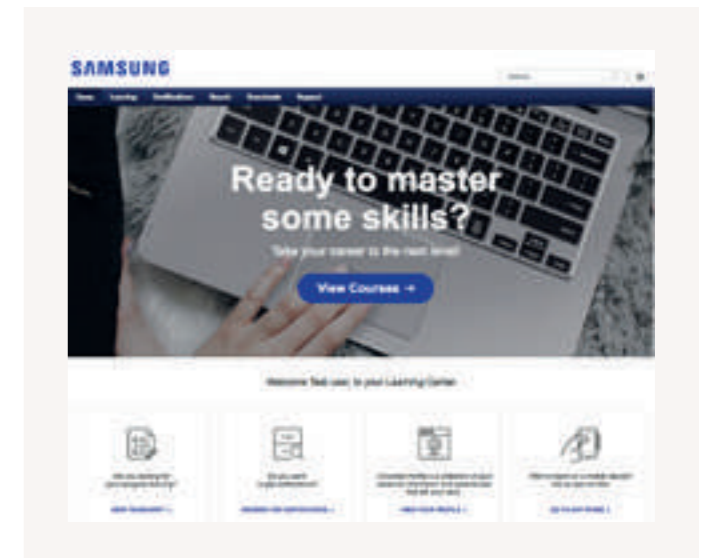

How to access



Register

To register for the Samsung Climate Solutions Partner Portal, open your web browser¹ and go to partnerhub.samsung.com/climate to complete the registration form.



Access

Your information will be verified and your account will be activated. You will receive your personal login details.



Manage account

Keep your account details up to date and invite your colleagues to join.



Search and download

Access a full library of resources, request technical support, or sign up for a Climate Solutions Academy training session.

¹ Google Chrome is the recommended web browser for using the Samsung Climate Solutions Partner Portal.

Samsung specialist design support

Bringing together technical expertise and practical experience in climate system design, Samsung provides a single point of contact for the design and management of cooling and heating installations in buildings. With assistance ranging from 3D visualisations with BIM support to CFD analysis to optimise indoor thermal conditions and BREEAM assessments to achieve the best environmental performance, Samsung's specialist engineers are ready to support you in making your project a success.

BIM support

Building Information Modelling (BIM) is an intelligent 3D model-based process for creating and managing information on the physical and functional characteristics of a building, across the project lifecycle and covering all parties involved, including the supply chain. BIM gives architects, engineers and construction professionals the insights and tools necessary to efficiently plan, design, construct and manage buildings and infrastructure.

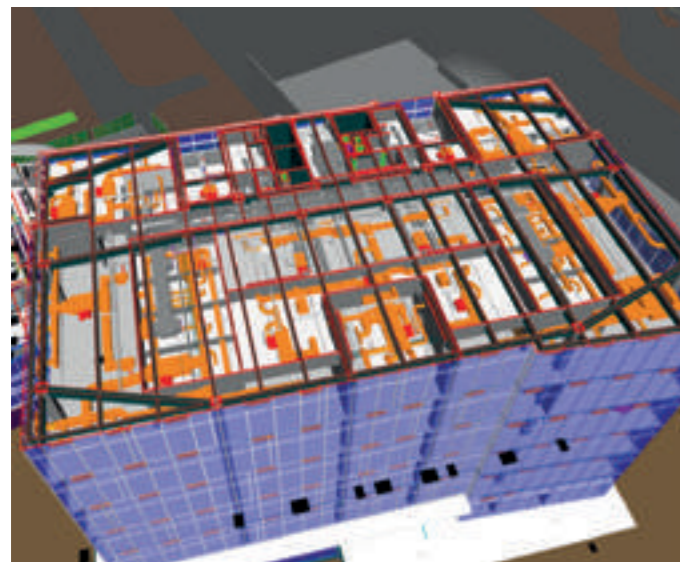
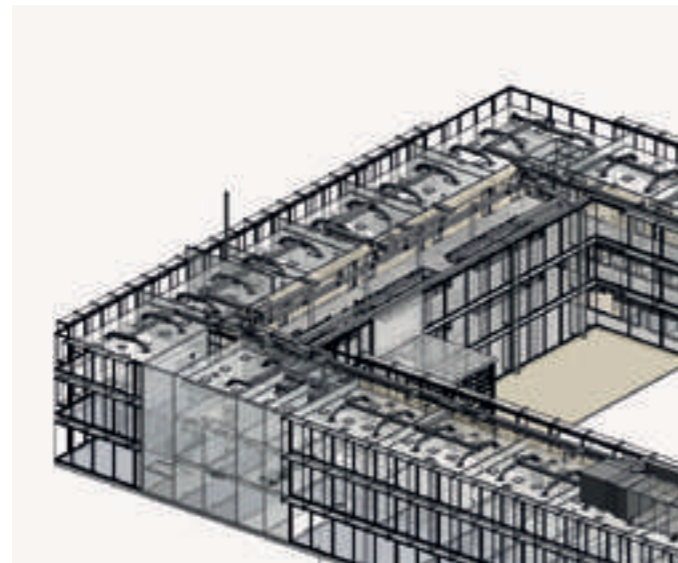

To support you as one of our Climate Solutions partners, Samsung has developed a full range of BIM models for all VRF and VRF Chiller products. You can download these 3D models directly from the BIM object library to start planning your project design. Alternatively, you can call on our qualified Samsung engineering team for dedicated project design support, using Revit® software to create 3D plans of the building including Samsung air conditioner installations.

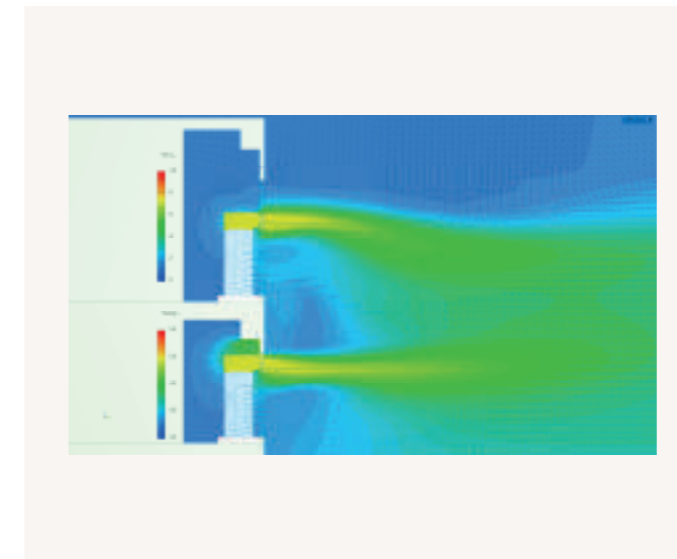

CFD analysis

Computational Fluid Dynamics (CFD) uses numerical analysis and data structures to analyse thermal conditions in buildings. It allows the virtual testing and optimisation of various climate system configurations in the context of occupant comfort, energy efficiency and running cost. Samsung can offer you specialist CFD support that includes analyses such as indoor temperature profiling, airflow distribution and sound simulation.

BREEAM evaluations

BREEAM (BRE¹ Environmental Assessment Method) is one of the most widely used environmental assessment methods and rating systems for buildings. It sets the standard for best practice in sustainable design and has become the de facto measure used to describe a building's environmental performance. Samsung's Accredited Professionals (APs) can support you in assessing the optimal installation for achieving a high certification score to match your green building programme.

¹BRE (Building Research Establishment) is a leading, multidisciplinary building science centre based in the United Kingdom.



How to obtain support



BIM support

To download Samsung BIM models, go to the Technical Resources on partnerhub.samsung.com/climate¹. To request dedicated project design support from Samsung, please contact your Samsung representative.



CFD analysis

To obtain CFD analysis support from Samsung, please contact your Samsung representative. Certain conditions may apply, subject to the project.



BREEAM evaluations

Please contact your Samsung representative to request a BREEAM evaluation by one of Samsung's Accredited Professionals (APs).

¹ Google Chrome is the recommended web browser for using the Samsung Climate Solutions Partner Portal.

Samsung Climate Solutions Academy

Samsung Climate Solutions Academy is committed to providing engineers with the technical skills required to install a Samsung product efficiently, and to help relay necessary information to users. All courses are designed to provide attendees with the opportunity to develop both theoretical and practical knowledge of Samsung's vast range of equipment and solutions.

Samsung training centres in Europe



Available training modules

Essential courses: Basic commercial training

- The product line-up, accessories and available controls
- The unique features of Samsung products
- Installation considerations

Advanced courses: Technical training

- How to correctly install and configure a system
- Commissioning: common issues during commissioning and how to resolve any challenges
- Troubleshooting and fault-finding (by use of E-codes)
- Control logic
- Case studies

Advanced courses: Design training

- Understanding customers' needs and offering possible solutions
- DVM-Pro - Samsung's advanced design tool
- Case studies

Note: the registration process for and availability of training courses may vary per country. Please contact your Samsung representative for more information.

How to register for training



Search

To check for available training courses, go to Samsung Business Academy (SBA) via the Samsung Climate Solutions Partner Portal¹: partnerhub.samsung.com/climate. Search the online event calendar and select the training course you would like to attend.



Register

After identifying the training course you would like to attend, follow the registration process. Once you have registered successfully you will receive a confirmation e-mail.



Get certified

Following confirmation of your registration, we will invite you to one of our training centres. You will be trained by one of our specialised Master Trainers or Product Specialists, and receive a Certificate of Completion.

¹ Google Chrome is the recommended web browser for using the Samsung Climate Solutions Partner Portal.



Learn more about Samsung Climate Solutions at:
www.samsung.com/climate

Copyright © 2020 Samsung Electronics Air Conditioner Europe B.V. All rights reserved. Samsung is a registered trademark of Samsung Electronics Co., Ltd. Specifications and designs are subject to change without notice and may include preliminary information. Non-metric weights and measurements are approximate. All data was deemed correct at the time of creation. Samsung is not liable for errors or omissions. Some images may be digitally altered. All brand, product, service names and logos are trademarks and/or registered trademarks of their respective owners and are hereby recognised and acknowledged.



Samsung Electronics Co., Ltd. participates in the Eurovent Certification Programme (ECP) for Air Conditioners (AC), Variable Refrigerant Flow (VRF) and Liquid Chilling Packages Heat Pump (LCP-HP). To check the ongoing validity of certification, please visit: www.eurovent-certification.com

Samsung Electronics Air Conditioner Europe B.V.
Evert van de Beekstraat 310, 1118 CX Schiphol
P.O. Box 75810, 1118 ZZ Schiphol
+31 (0)8 81 41 61 00
The Netherlands

SAMSUNG